

**IABU Headquarters****Delta Electronics, Inc.**

Taoyuan1
31-1, Xingbang Road, Guishan Industrial Zone,
Taoyuan County 33370, Taiwan, R.O.C.
TEL: 886-3-362-6301 / FAX: 886-3-362-7267

ASIA**Delta Electronics (Jiang Su) Ltd.**

Wujiang Plant3
1688 Jiangxing East Road,
Wujiang Economy Development Zone,
Wujiang City, Jiang Su Province,
People's Republic of China (Post code: 215200)
TEL: 86-512-6340-3008 / FAX: 86-512-6340-7290

Delta Greentech (China) Co., Ltd.

238 Min-Xia Road, Cao-Lu Industry Zone, Pudong, Shanghai,
People's Republic of China
Post code : 201209
TEL: 021-58635678 / FAX: 021-58630003

Delta Electronics (Japan), Inc.

Tokyo Office
Delta Shibadaimon Building, 2-1-14
Shibadaimon, Minato-Ku, Tokyo, 105-0012,
Japan
TEL: 81-3-5733-1111 / FAX: 81-3-5733-1211

Delta Electronics (Korea), Inc.

234-9, Duck Soo Building 7F, Nonhyun-Dong,
Kangnam-Gu, Seoul, Korea 135-010
TEL: 82-2-515-5305 / FAX: 82-2-515-5302

Delta Electronics (Singapore) Pte. Ltd.

8 Kaki Bukit Road 2, #04-18 Ruby Warehouse Complex,
Singapore 417841
TEL: 65-6747-5155 / FAX: 65-6744-9228

Delta Power Solutions (India) Pte. Ltd.

Plot No. 28, Sector-34, EHTP
Gurgaon-122001 Haryana, India
TEL: 91-124-416-9040 / FAX: 91-124-403-6045

AMERICA**Delta Products Corporation (USA)**

Raleigh Office
P.O. Box 12173, 5101 Davis Drive,
Research Triangle Park, NC 27709, U.S.A.
TEL: 1-919-767-3813 / FAX: 1-919-767-3969

Delta Products Corporation (Brazil)

Sao Paulo Office
Rua Jardim Ivone, 17 Cjs 13/14-Paraiso
04105-020-Sao Paulo-SP-Brazil
TEL: 55-11-3568-3875 / FAX: 55-11-3568-3865

EUROPE**Deltronics (The Netherlands) B.V.**

Eindhoven Office
De Witbogt 15, 5652 AG Eindhoven, The Netherlands
TEL: 31-40-2592850 / FAX: 31-40-2592851

*We reserve the right to change the information in this manual without prior notice

ASDA-A2_M_EN_20110128

**ASDA-A2 Series User Manual**

ASDA-A2 Series

User Manual

High Resolution AC Servo Drive for Network
Communication Applications



www.delta.com.tw/industrialautomation

Preface

Thank you very much for purchasing DELTA's AC servo products.

This manual will be helpful in the installation, wiring, inspection, and operation of Delta AC servo drive and motor. Before using the product, please read this user manual to ensure correct use.

You should thoroughly understand all safety precautions (DANGERS, WARNINGS and STOPS) before proceeding with the installation, wiring and operation. If you do not understand please contact your local Delta sales representative. Place this user manual in a safe location for future reference.

Using This Manual

■ Contents of this manual

This manual is a user guide that provides the information on how to install, operate and maintain ASDA-A2 series AC servo drives and ECMA series AC servo motors. The contents of this manual are including the following topics:

- Installation of AC servo drives and motors
- Configuration and wiring
- Trial run steps
- Control functions and adjusting methods of AC servo drives
- Parameter settings
- Communication protocol
- Inspection and maintenance
- Troubleshooting
- Application examples

■ Who should use this manual

This user manual is intended for the following users:

- Those who are responsible for designing.
- Those who are responsible for installing or wiring.
- Those who are responsible for operating or programming.
- Those who are responsible for maintaining or troubleshooting.

■ Important precautions

Before using the product, please read this user manual thoroughly to ensure correct use and store this manual in a safe and handy place for quick reference whenever necessary. Besides, please observe the following precautions:

- Do not use the product in a potentially explosive environment.
- Install the product in a clean and dry location free from corrosive and inflammable gases or liquids.

- Do not connect a commercial power supply to the U, V, W terminals of motor. Failure to observe this precaution will damage either the Servo motor or drive.
- Ensure that the motor and drive are correctly connected to a ground. The grounding method must comply with the electrical standard of the country (Please refer to NFPA 70: National Electrical Code, 2005 Ed.).
- Do not disconnect the AC servo drive and motor while the power is ON.
- Do not attach, modify and remove wiring when power is applied to the AC servo drive and motor.
- Before starting the operation with a mechanical system connected, make sure the emergency stop equipment can be energized and work at any time.
- Do not touch the drive heat sink or the servo motor during operation. Otherwise, it may result in serious personnel injury.

PLEASE READ PRIOR TO INSTALLATION FOR SAFETY.

Carefully note and observe the following safety precautions when receiving, inspecting, installing, operating, maintaining and troubleshooting. The following words, DANGER, WARNING and STOP are used to mark safety precautions when using the Delta's servo product.

Failure to observe these precautions may void the warranty!

ASDA-A2 series drives are high-resolution, open type servo drives and must be installed in an NEMA enclosure such as a protection control panel during operation to comply with the requirements of the international safety standards. They are provided with precise feedback control and high-speed calculation function incorporating DSP (Digital Signal Processor) technology, and intended to drive three-phase permanent magnet synchronous motors (PMSM) to achieve precise positioning by means of accurate current output generated by IGBT (Insulated Gate Bipolar Transistor).

ASDA-A2 series drives can be used in industrial applications and for installation in an end-use enclosure that do not exceed the specifications defined in the ASDA-A2 series user manual (Drives, cables and motors are for use in a suitable enclosure with a minimum of a UL50 type 1 or NEMA 250 Type 1 rating).

The words, DANGER, WARNING and STOP, have the following meaning:



Indicates a potentially hazardous situation and if not avoided, may result in serious injury or death.



Indicates a potentially hazardous situation and if not avoided, may result in minor to moderate injury or serious damage to the product.



Indicates an improper action that it is not recommended to do and if doing it may cause damage, malfunction and inability.

Unpacking Check



- *Please ensure that both the servo drive and motor are correctly matched for size (power rating). Failure to observe this precaution may cause fire, seriously damage the drive / motor or cause personal injury.*

Installation



- *Do not install the product in a location that is outside the stated specification for the drive and motor. Failure to observe this caution may result in electric shock, fire, or personal injury.*

Wiring



- *Connect the ground terminals to a class-3 ground (Ground resistance should not exceed 100 Ω). Improper grounding may result in electric shock or fire.*
- *Do not connect any power supplies to the U, V, W terminals. Failure to observe this precaution may result in serious injury, damage to the drive or fire.*
- *Ensure that all screws, connectors and wire terminations are secure on the power supply, servo drive and motor. Failure to observe this caution may result in damage, fire or personal injury.*
- *In order to prevent fire hazard and accidents, please form the wiring by the cable specifications outlined in this user manual.*

Operation



- *Before starting the operation with a mechanical system connected, change the drive parameters to match the user-defined parameters of the mechanical system. Starting the operation without matching the correct parameters may result in servo drive or motor damage, or damage to the mechanical system.*
- *Ensure that the emergency stop equipment or device is connected and working correctly before operating the motor that is connected to a mechanical system.*



- *Do not approach or touch any rotating parts (e.g. shaft) while the motor is running. Failure to observe this precaution may cause serious personal injury.*



- *In order to prevent accidents, the initial trial run for servo motor should be conducted under no load conditions (separate the motor from its couplings and belts).*
- *For the initial trial run, do not operate the servo motor while it is connected to its mechanical system. Connecting the motor to its mechanical system may cause damage or result in personal injury during the trial run. Connect the servo motor once it has successfully completed a trial run.*
- *Caution: Please perform trial run without load first and then perform trial run with load connected. After the servo motor is running normally and regularly without load, then run servo motor with load connected. Ensure to perform trial run in this order to prevent unnecessary danger.*
- *Do not touch either the drive heat sink or the motor during operation as they may become hot and personal injury may result.*

Maintenance and Inspection



- *Do not touch any internal or exposed parts of servo drive and servo motor as electrical shock may result.*
- *Do not remove the operation panel while the drive is connected to an electrical power source otherwise electrical shock may result.*
- *Wait at least 10 minutes after power has been removed before touching any drive or motor terminals or performing any wiring and/or inspection as an electrical charge may still remain in the servo drive and servo motor with hazardous voltages even after power has been removed.*
- *Do not disassemble the servo drive or motor as electric shock may result.*
- *Do not connect or disconnect wires or connectors while power is applied to the drive and motor.*
- *Only qualified personnel who have electrical knowledge should conduct maintenance and inspection.*
- *Ensure that the “Charge” indicator ceases when performing any maintenance, inspection or repairing.*

Main Circuit Wiring



- *Install the encoder cables in a separate conduit from the motor power cables to avoid signal noise. Separate the conduits by 30cm (11.8inches) above.*
- *Use multi-stranded twisted-pair wires or multi-core shielded-pair wires for signal, encoder (PG) feedback cables. The maximum length of command input cable is 3m (9.84ft.) and the maximum length of encoder (PG) feedback cables is 20m (65.62ft.).*
- *As a charge may still remain in the drive with hazardous voltages even after power has been removed, be sure to wait at least 10 minutes after power has been removed before performing any wiring and/or inspection.*



- *It is not recommended to frequently power the drive on and off. Do not turn the drive off and on more than once per minute as high charging currents within the internal capacitors may cause damage.*

Main Circuit Terminal Wiring



- *Please perform the wiring after the terminal blocks are all removed from the drive.*
- *Insert only one wire into one terminal on the terminal block.*
- *When inserting wires, please ensure that the conductors are not shorted to adjacent terminals or wires.*
- *Ensure to double check the wiring before applying power to the drive.*

**NOTE**

- 1) In this manual, actual measured values are in metric units. Dimensions in (imperial units) are for reference only. Please use metric for precise measurements.
- 2) The content of this manual may be revised without prior notice. Please consult our distributors or download the most updated version at <http://www.delta.com.tw/industrialautomation>.

Chapter 1 Unpacking Check and Model Explanation

1.1 Unpacking Check

After receiving the AC servo drive, please check for the following:

- **Ensure that the product is what you have ordered.**

Verify the part number indicated on the nameplate corresponds with the part number of your order (Please refer to Section 1.2 for details about the model explanation).

- **Ensure that the servo motor shaft rotates freely.**

Rotate the motor shaft by hand; a smooth rotation will indicate a good motor. However, a servo motor with an electromagnetic brake can not be rotated manually.

- **Check for damage.**

Inspect the unit to insure it was not damaged during shipment.

- **Check for loose screws.**

Ensure that all necessary screws are tight and secure.

If any items are damaged or incorrect, please inform the distributor whom you purchased the product from or your local Delta sales representative.

A complete and workable AC servo system should include the following parts:

Part I : Delta standard supplied parts

220V series

- (1) Servo drive
- (2) Servo motor
- (3) 6 PIN Terminal Block (for L1c, L2c, \ominus , R, S, T) (available for 200W ~ 1.5kW models)
- (4) 3 PIN Terminal Block (for R, S, T) (available for 2kW ~ 3kW models)
- (5) 3 PIN Terminal Block (for L1c, L2c, \ominus) (available for 2kW ~ 3kW models)
- (6) 6 PIN Terminal Block (for L1c, L2c, \ominus , R, S, T) (available for 4.5kW ~ 7.5kW models)
- (7) 3 PIN Quick Connector (for U, V, W)
- (8) 3 PIN Quick Connector (for P \oplus , D, C)
- (9) One operating lever (for wire to terminal block insertion)
- (10) One jumper bar (installed at pins P \oplus and D of the 3 PIN Terminal Block for P \oplus , D, C)
- (11) Instruction Sheets (Multilingual version)

400V series

- (1) Servo drive
- (2) Servo motor
- (3) 3 PIN Terminal Block (for R, S, T) (available for 750W ~ 1.5kW models)
- (4) 3 PIN Terminal Block (for DC24V, DC0V, \ominus) (available for 750W ~ 1.5kW models)
- (5) Terminal Block (for DC24V, DC0V, R, S, T) (available for 2kW ~ 7.5kW models)
- (6) 3 PIN Quick Connector (for U, V, W)
- (7) 3 PIN Quick Connector (for P \oplus , D, C)
- (8) One operating lever (for wire to terminal block insertion)
- (9) One jumper bar (installed at pins P \oplus and D of the 3 PIN Terminal Block for P \oplus , D, C)
- (10) Instruction Sheets (Multilingual version)

Part II : Optional parts (Refer to Appendix A)

- (1) One power cable, which is used to connect servo motor to U, V, W terminals of servo drive. This power cable includes a green grounding cable. Please connect the green grounding cable to the ground terminal of the servo drive.
- (2) One encoder cable, which is used to connect the encoder of servo motor to the CN2 terminal of servo drive.
- (3) CN1 Connector: 50 PIN Connector (3M type analog product)
- (4) CN2 Connector: 20 PIN Connector (3M type analog product)
- (5) CN3 Connector: 6 PIN Connector (IEEE1394 analog product) for general communication (RS-485)
- (6) CN4 Connector: 4 PIN Connector (USB Type B product)
- (7) CN6 Connector: RJ45 Connector for high-speed communication (CANopen)

1.2 Model Explanation

1.2.1 Nameplate Information

ASDA-A2 Series Servo Drive

■ Nameplate Explanation

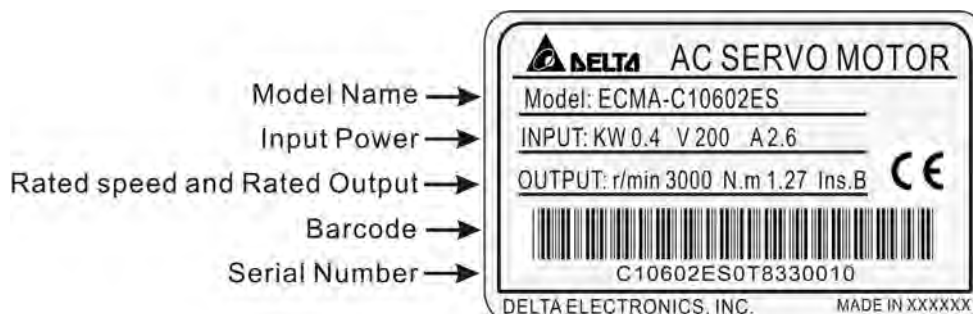


■ Serial Number Explanation

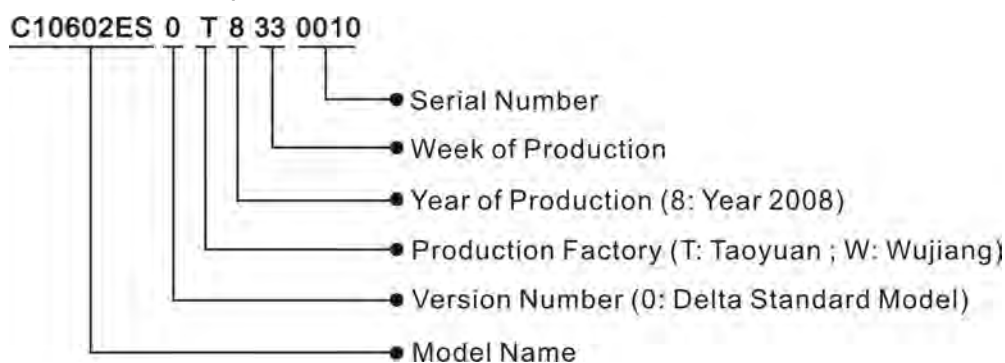


ECMA Series Servo Motor

■ Nameplate Explanation

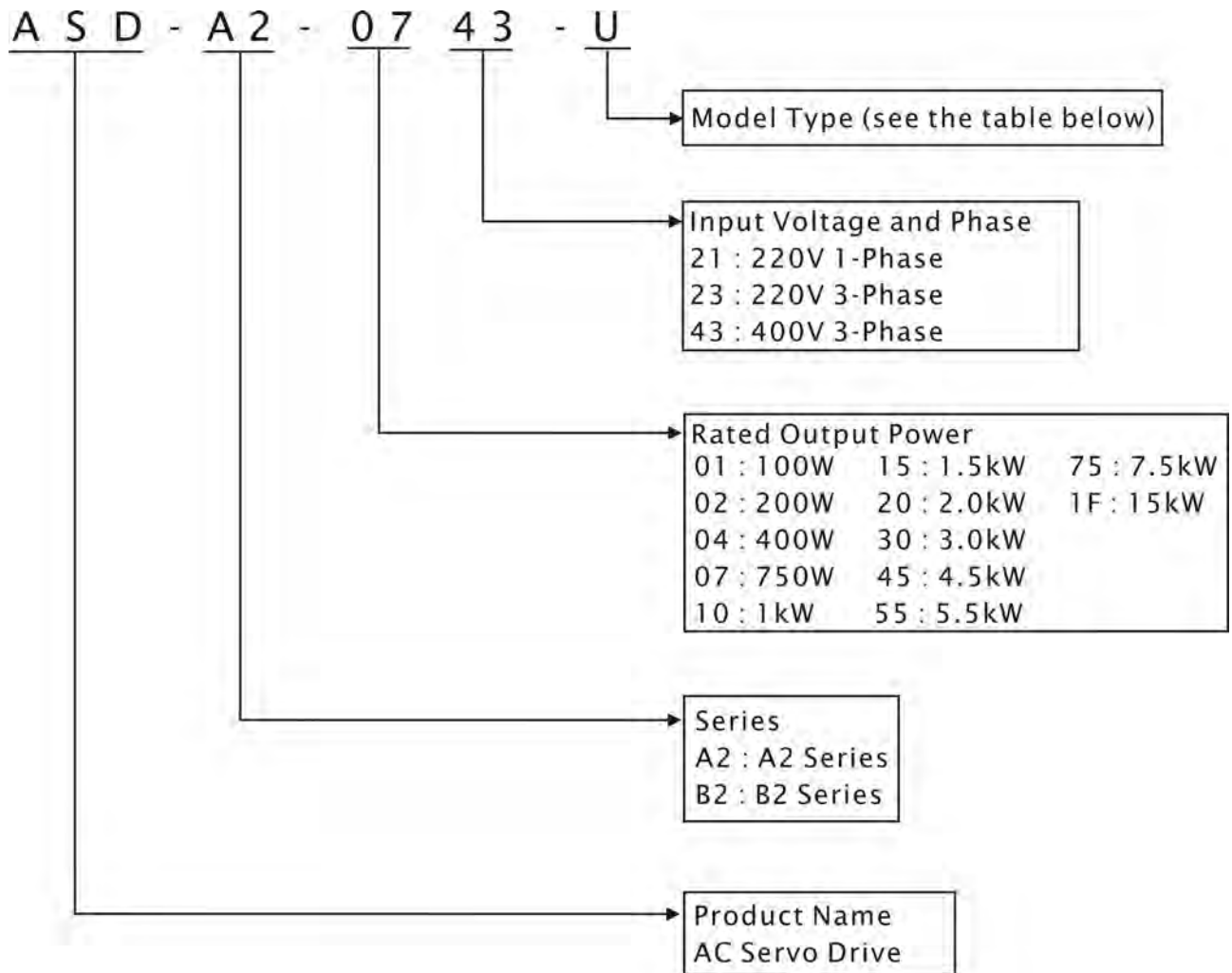


■ Serial Number Explanation



1.2.2 Model Name Explanation

ASDA-A2 Series Servo Drive



Model Type

Type	Full-Close Control	CANopen	DMCNET	Extension Port for Digital Input
M	Yes	Yes	No	No
U	Yes	No	No	Yes
F	Yes	No	Yes	No
L	Yes	No	No	No

NOTE

15kW models will be available soon. The models above 15kW are in the process of development.

ECMA Series Servo Motor

E C M A - C 1 0 6 0 2 E S

Standard Shaft Dimensions: S
Specified Shaft Dimensions:
3=42mm, 7=14mm

Shaft Type and Oil seal	W/O Brake W/O Oil Seal	With Brake W/O Oil Seal	W/O Brake With Oil Seal	With Brake With Oil Seal
Round Shaft (with screw hole)	A	B	C	D
Keyway	E	F	G	H
Keyway (with screw hole)	P	Q	R	S

Rated Output Power

01 : 100W	06 : 600W	20 : 2.0kW	1F : 15kW
02 : 200W	07 : 750W	30 : 3.0kW	
03 : 300W	09 : 900W	45 : 4.5kW	
04 : 400W	10 : 1.0kW	55 : 5.5kW	
05 : 500W	15 : 1.5kW	75 : 7.5kW	

Motor Frame Size

04 : 40mm	09 : 86mm	18 : 180mm
06 : 60mm	10 : 100mm	
08 : 80mm	13 : 130mm	

Series
Rated Voltage / Rated Speed
C : 220V / 3000 r/min J : 400V / 3000 r/min
E : 220V / 2000 r/min K : 400V / 2000 r/min
F : 220V / 1500 r/min L : 400V / 1500 r/min
G : 220V / 1000 r/min
Sensor Tyoe
1: Incremental encoder, 20-bit

Driving Type
A: AC Servo Motor

Product Type
ECM: Electrical Commutation Motor

 **NOTE**

15kW models will be available soon. The models above 15kW are in the process of development.

1.3 Servo Drive and Servo Motor Combinations

The table below shows the possible combination of Delta ASDA-A2 series servo drives and ECMA series servo motors. (Please refer to Section 1.2 for model explanation)

1.3.1 220V Series

Power	Servo Drive	Servo Motor
100W	ASD-A2-0121-□	ECMA-C10401□S (S=8mm)
200W	ASD-A2-0221-□	ECMA-C10602□S (S=14mm)
400W	ASD-A2-0421-□	ECMA-C10604□S (S=14mm) ECMA-C10804□7 (7=14mm) ECMA-E11305□S (S=22mm) ECMA-G11303□S (S=22mm)
750W	ASD-A2-0721-□	ECMA-C10807□S (S=19mm) ECMA-G11306□S (S=22mm)
1000W	ASD-A2-1021-□	ECMA-C11010□S (S=22mm) ECMA-E11310□S (S=22mm) ECMA-G11309□S (S=22mm)
1500W	ASD-A2-1521-□	ECMA-E11315□S (S=22mm)
2000W	ASD-A2-2023-□	ECMA-C11020□S (S=22mm) ECMA-E11320□S (S=22mm) ECMA-E11820□S (S=35mm)
3000W	ASD-A2-3023-□	ECMA-E11830□S (S=35mm) ECMA-F11830□S (S=35mm)
4500W	ASD-A2-4523-□	ECMA-F11845□S (S=35mm)
5500W	ASD-A2-5523-□	ECMA-F11855□3 (3=42mm)
7500W	ASD-A2-7523-□	ECMA-F11875□3 (3=42mm)

NOTE

- 1) The boxes (□) at the ends of the servo drive model names are for optional configurations (Full-close control, CANopen, DMCNET and extension port for digital input). For the actual model name, please refer to the ordering information of the actual purchased product.
- 2) The boxes (□) in the servo motor model names are for optional configurations (keyway, brake and oil seal).

The drives shown in the above table are designed according to the three multiple of rated current of motors shown in the above table. If the drives which are designed according to the six multiple of rated current of motors are needed, please contact our distributors or your local Delta sales representative.

1.3.2 400V Series

Power	Servo Drive	Servo Motor
750W	ASD-A2-0743-□	ECMA-J10807□S (S=19mm)
1000W	ASD-A2-1043-□	ECMA-K11310□S (S=22mm)
1500W	ASD-A2-1543-□	ECMA-K11315□S (S=22mm)
2000W	ASD-A2-2043-□	ECMA-K11320□S (S=22mm)
3000W	ASD-A2-3043-□	ECMA-L11830□S (S=35mm)
4500W	ASD-A2-4543-□	ECMA-L11845□S (S=35mm)
5500W	ASD-A2-5543-□	ECMA-L11855□3 (3=42mm)
*7500W	ASD-A2-7543-□	ECMA-L11875□3 (3=42mm)

*7.5kW models will be available soon.

NOTE

- 1) The boxes (□) at the ends of the servo drive model names are for optional configurations (Full-close control, CANopen, DMCNET and extension port for digital input). For the actual model name, please refer to the ordering information of the actual purchased product.
- 2) The boxes (□) in the servo motor model names are for optional configurations (keyway, brake and oil seal).

The drives shown in the above table are designed according to the three multiple of rated current of motors shown in the above table. If the drives which are designed according to the six multiple of rated current of motors are needed, please contact our distributors or your local Delta sales representative.

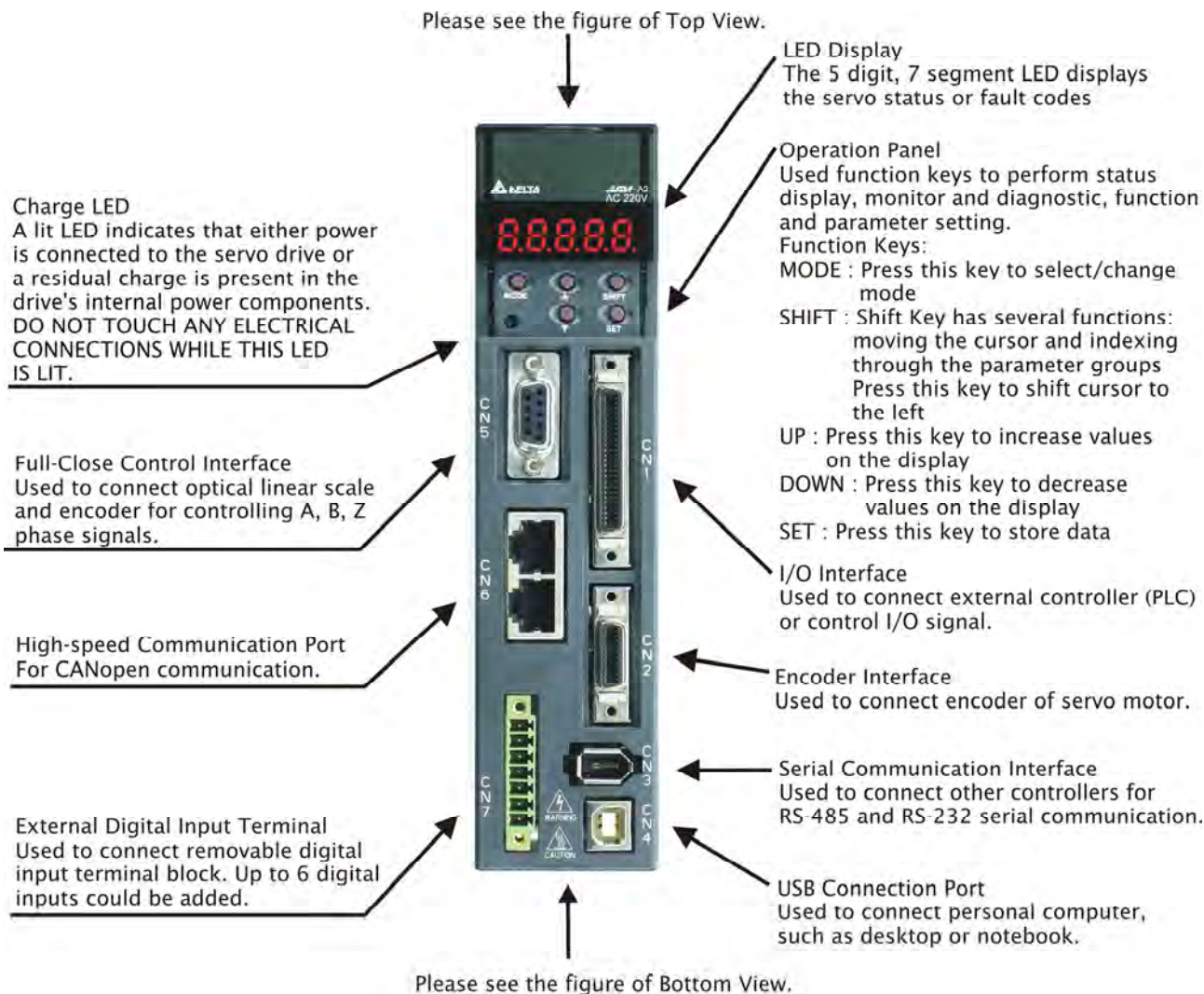
The servo drives shown in the above two tables are designed for use in combination with the specific servo motors. Check the specifications of the drives and motors you want to use.

Also, please ensure that both the servo drive and motor are correctly matched for size (power rating). If the power of motor and drive is not within the specifications, the drive and motor may overheat and servo alarm would be activated. For the detail specifications of servo drives and motors, please refer to Chapter 12 "Specifications".

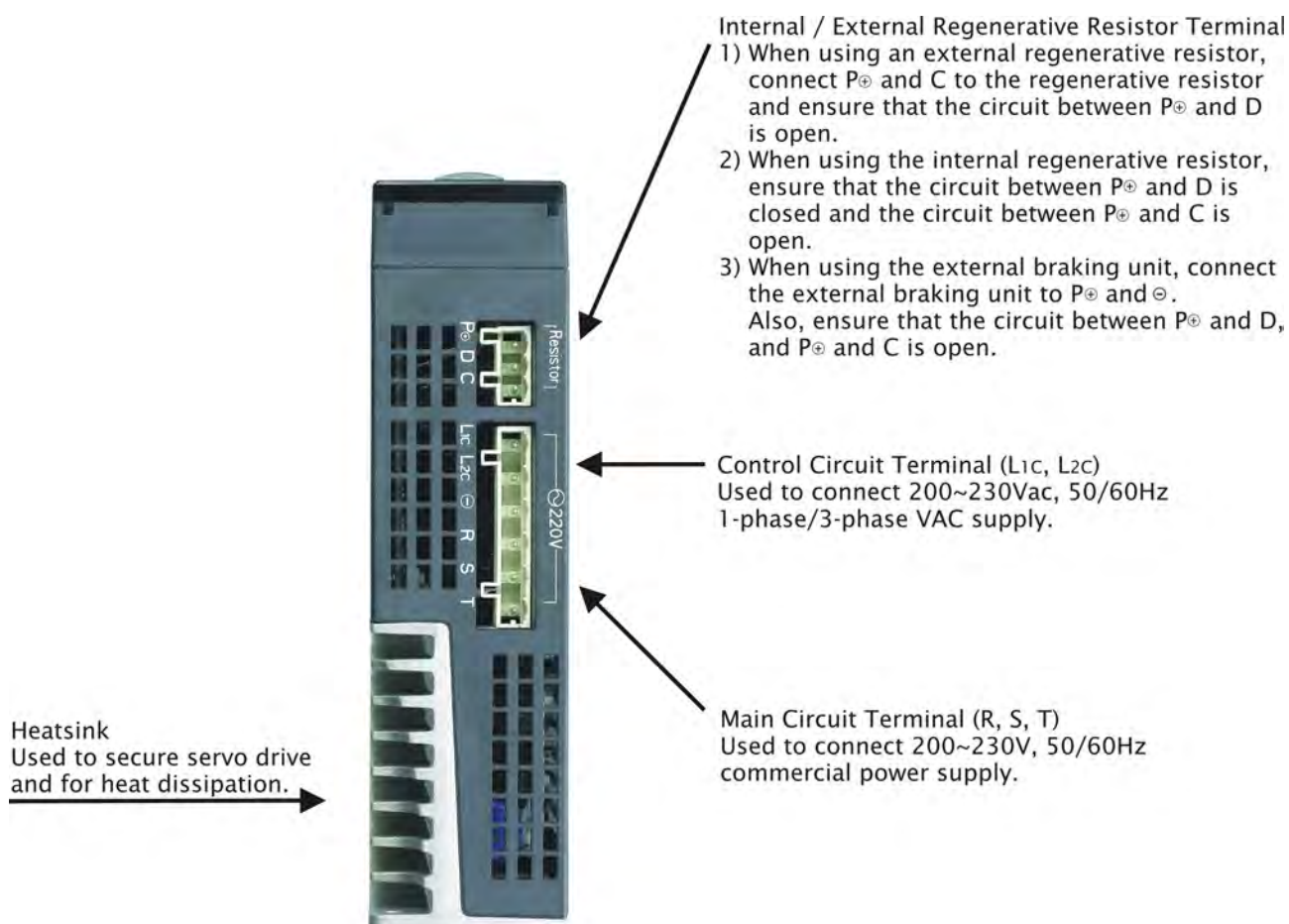
1.4 Servo Drive Features

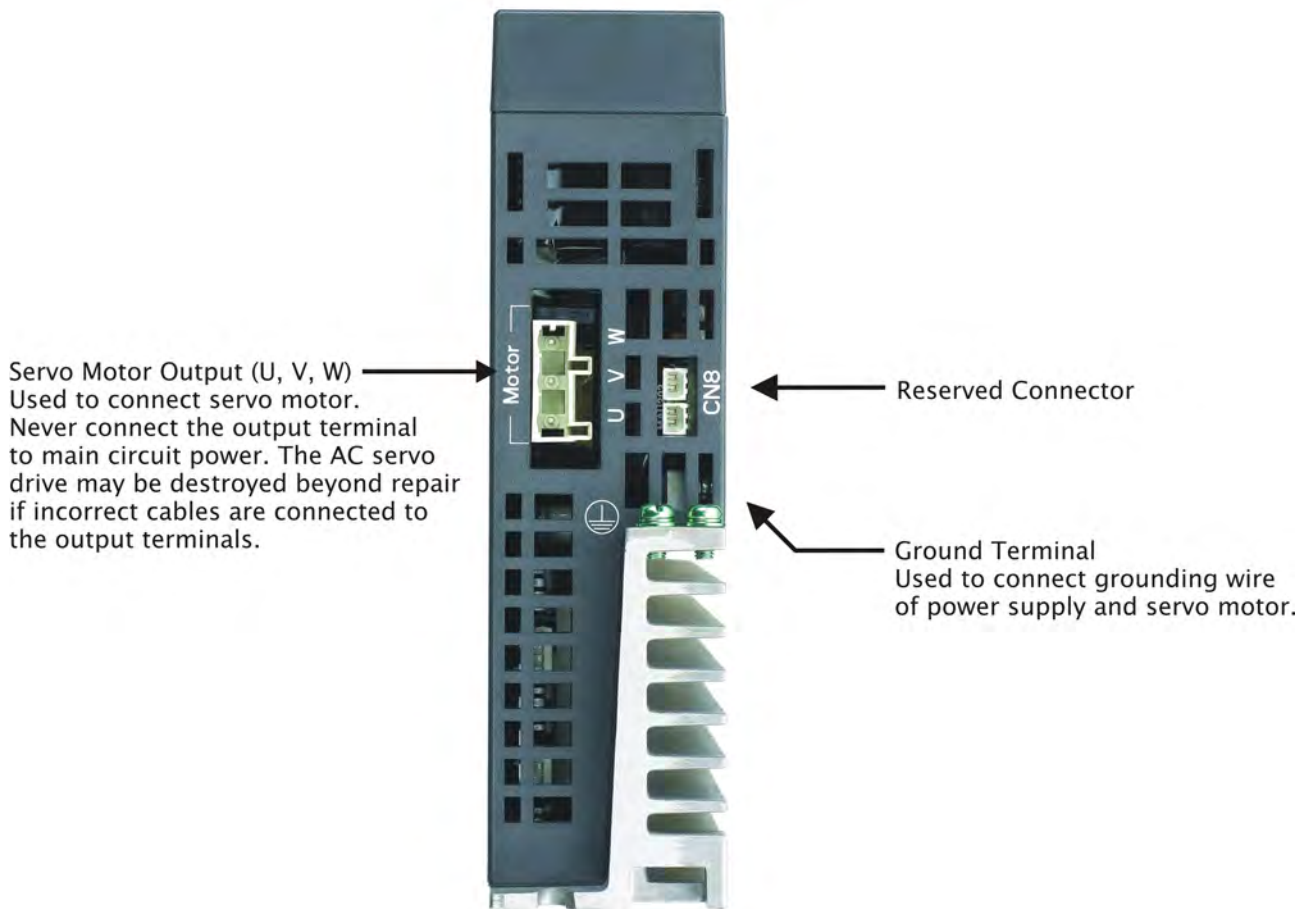
1.4.1 220V Series

220V Series - Front View



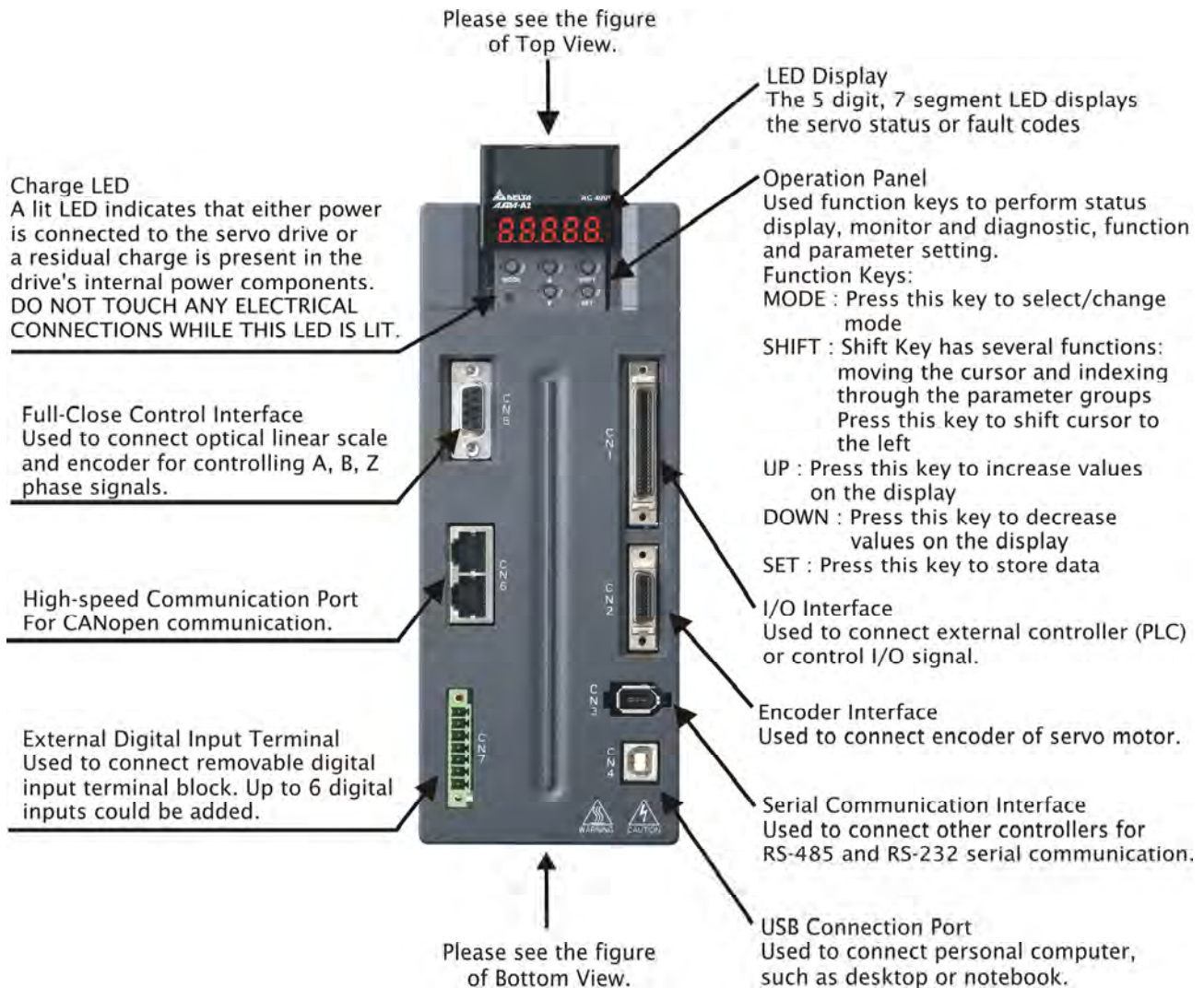
220V Series - Top View

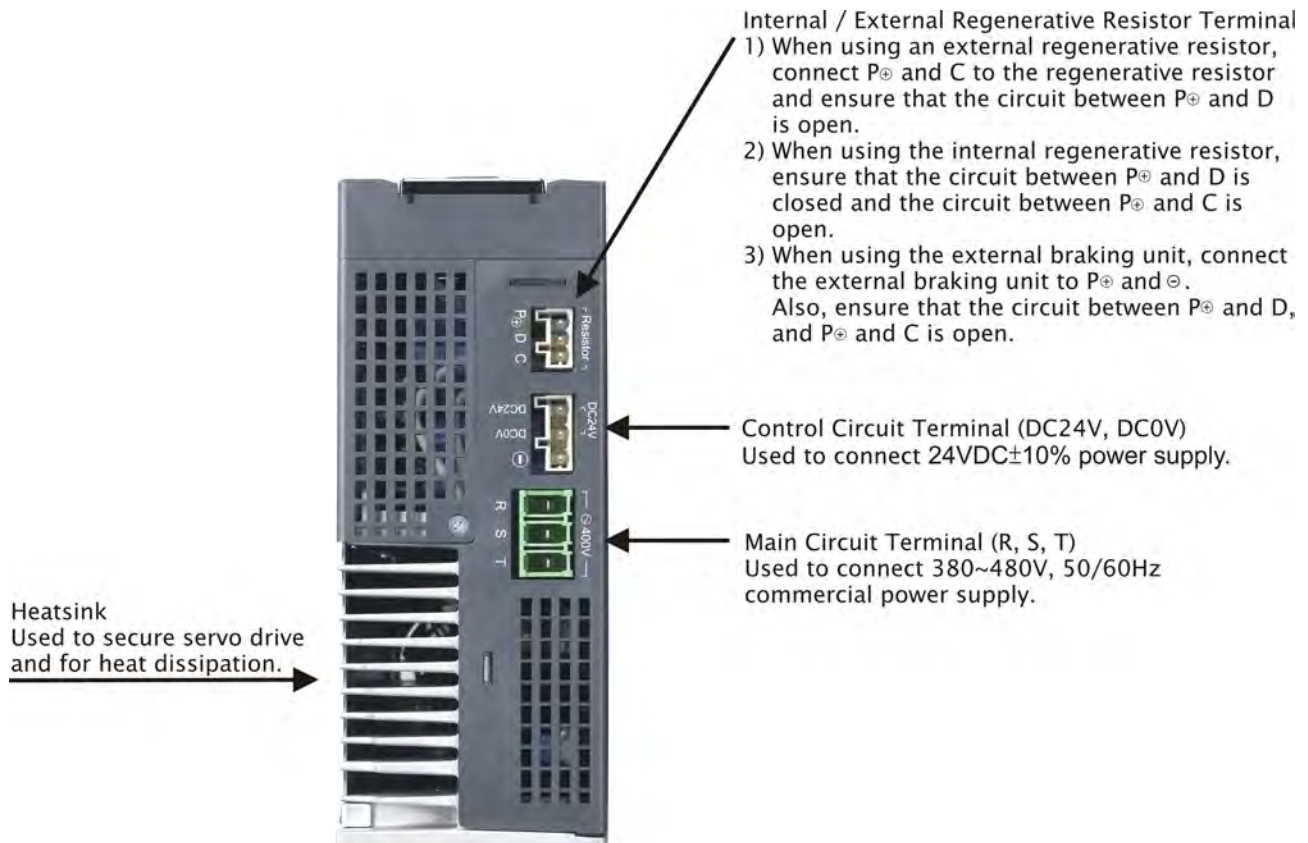


220V Series - Bottom View

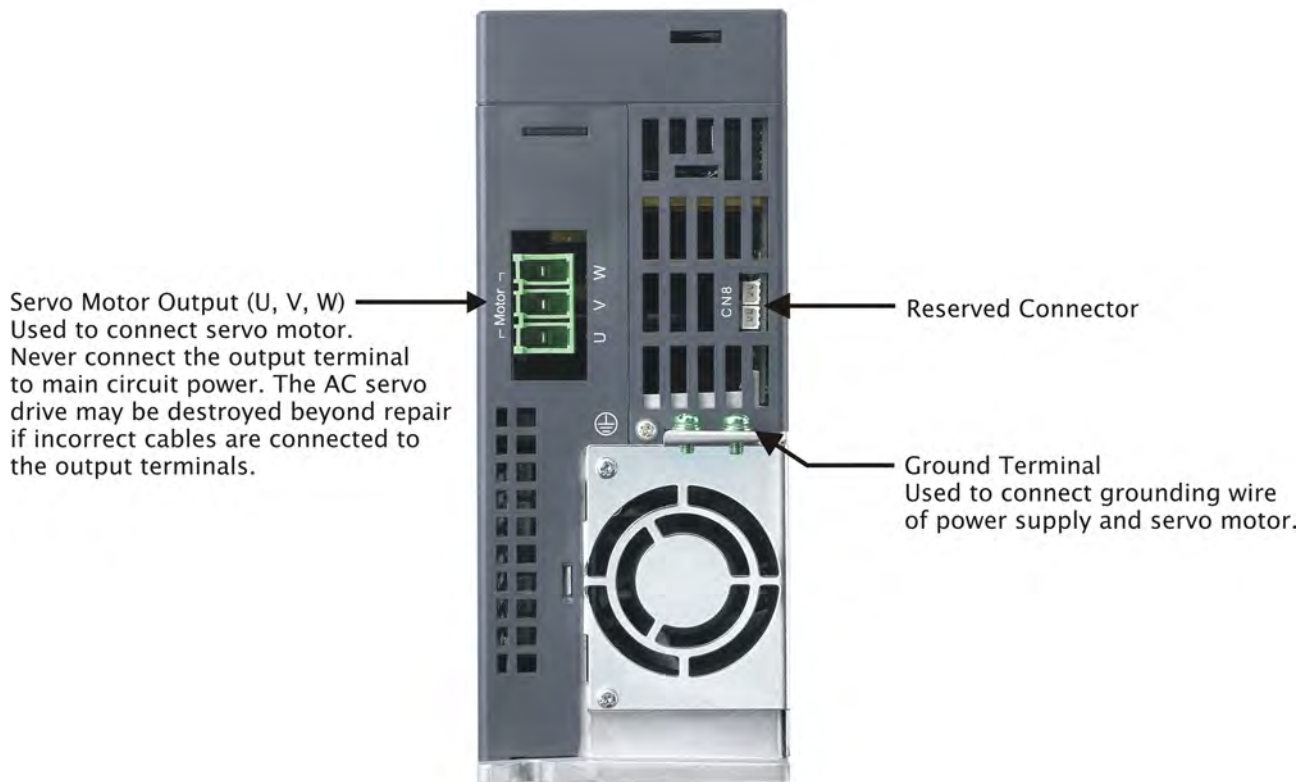
1.4.2 400V Series

400V Series - Front View



400V Series - Top View

400V Series - Bottom View



This page intentionally left blank

Chapter 2 Installation and Storage

2.1 Installation Notes

Please pay close attention on the following installation notes:

- Do not bend or strain the connection cables between servo drive and motor.
- When mounting the servo drive, make sure to tighten all screws to secure the drive in place.
- If the servo motor shaft is coupled directly to a rotating device ensure that the alignment specifications of the servo motor, coupling, and device are followed. Failure to do so may cause unnecessary loads or premature failure to the servo motor.
- If the length of cable connected between servo drive and motor is more than 20m, please increase the wire gauge of the encoder cable and motor connection cable (connected to U, V, W terminals).
- Make sure to tighten the screws for securing motor.

2.2 Storage Conditions

The product should be kept in the shipping carton before installation. In order to retain the warranty coverage, the AC servo drive should be stored properly when it is not to be used for an extended period of time. Some storage suggestions are:

- Store in a clean and dry location free from direct sunlight.
- Store within an ambient temperature range of -20°C to +65°C (-4°F to 149°F).
- Store within a relative humidity range of 0% to 90% and non-condensing.
- Do not store in a place subjected to corrosive gases and liquids.
- Correctly packaged and placed on a solid surface.

2.3 Installation Conditions

Operating Temperature

ASDA-A2 Series Servo Drive : 0°C to 55°C (32°F to 131°F)

ECMA Series Servo Motor : 0°C to 40°C (32°F to 104°F)

The ambient temperature of servo drive for long-term reliability should be under 45°C (113°F).

If the ambient temperature of servo drive is greater than 45°C (113°F), please install the drive in a well-ventilated location and do not obstruct the airflow for the cooling fan.

Caution

The servo drive and motor will generate heat. If they are installed in a control panel, please ensure sufficient space around the units for heat dissipation.

Pay particular attention to vibration of the units and check if the vibration has impacted the electric devices in the control panel. Please observe the following precautions when selecting a mounting location. ***Failure to observe the following precautions may void the warranty!***

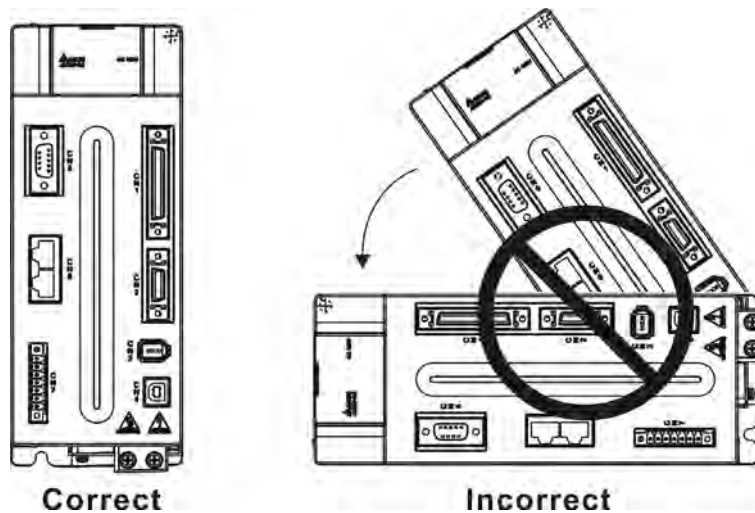
- Do not mount the servo drive or motor adjacent to heat-radiating elements or in direct sunlight.
- Do not mount the servo drive or motor in a location subjected to corrosive gases, liquids, or airborne dust or metallic particles.
- Do not mount the servo drive or motor in a location where temperatures and humidity will exceed specification.
- Do not mount the servo drive or motor in a location where vibration and shock will exceed specification.
- Do not mount the servo drive or motor in a location where it will be subjected to high levels of electromagnetic radiation.

2.4 Installation Procedure and Minimum Clearances

Installation Procedure

Incorrect installation may result in a drive malfunction or premature failure of the drive and or motor. Please follow the guidelines in this manual when installing the servo drive and motor.

The ASDA-A2 servo drive should be mounted perpendicular to the wall or in the control panel. In order to ensure the drive is well ventilated, ensure that the all ventilation holes are not obstructed and sufficient free space is given to the servo drive. Do not install the drive in a horizontal position or malfunction and damage will occur.



Drive Mounting

The ASDA-A2 Servo drives must be back mounted vertically on a dry and solid surface such as a NEMA enclosure. A minimum spacing of two inches must be maintained above and below the drive for ventilation and heat dissipation. Additional space may be necessary for wiring and cable connections. Also, as the drive conducts heat away via the mounting, the mounting plane or surface should not conduct heat into the drive from external sources

Motor Mounting

The ECMA Servo motors should be mounted firmly to a dry and solid mounting surface to ensure maximum heat transfer for maximum power output and to provide a good ground.

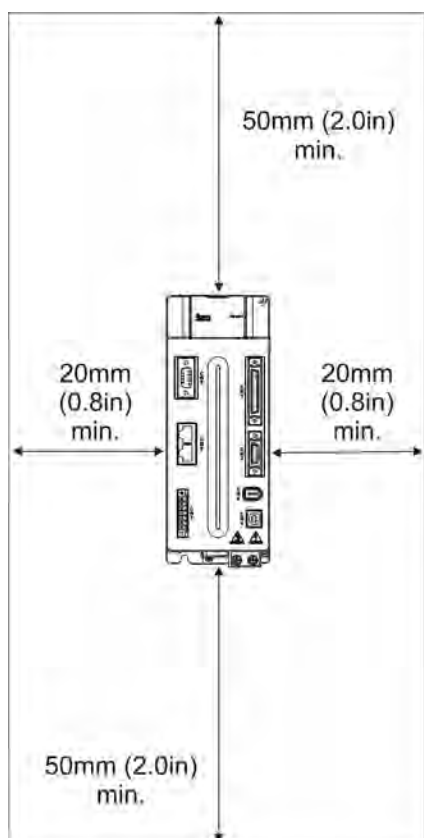
For the dimensions and weights specifications of servo drive or motor, please refer to Chapter 12 "Specifications".

Minimum Clearances

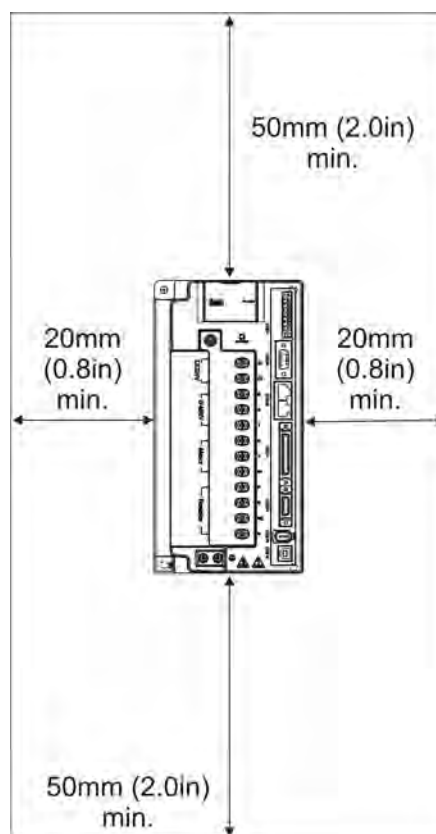
Install a fan to increase ventilation to avoid ambient temperatures that exceed the specification. When installing two or more drives adjacent to each other please follow the clearances as shown in the following diagram.

■ **Minimum Clearances**

750W ~ 1.5kW models:



2kW ~ 5.5kW models:

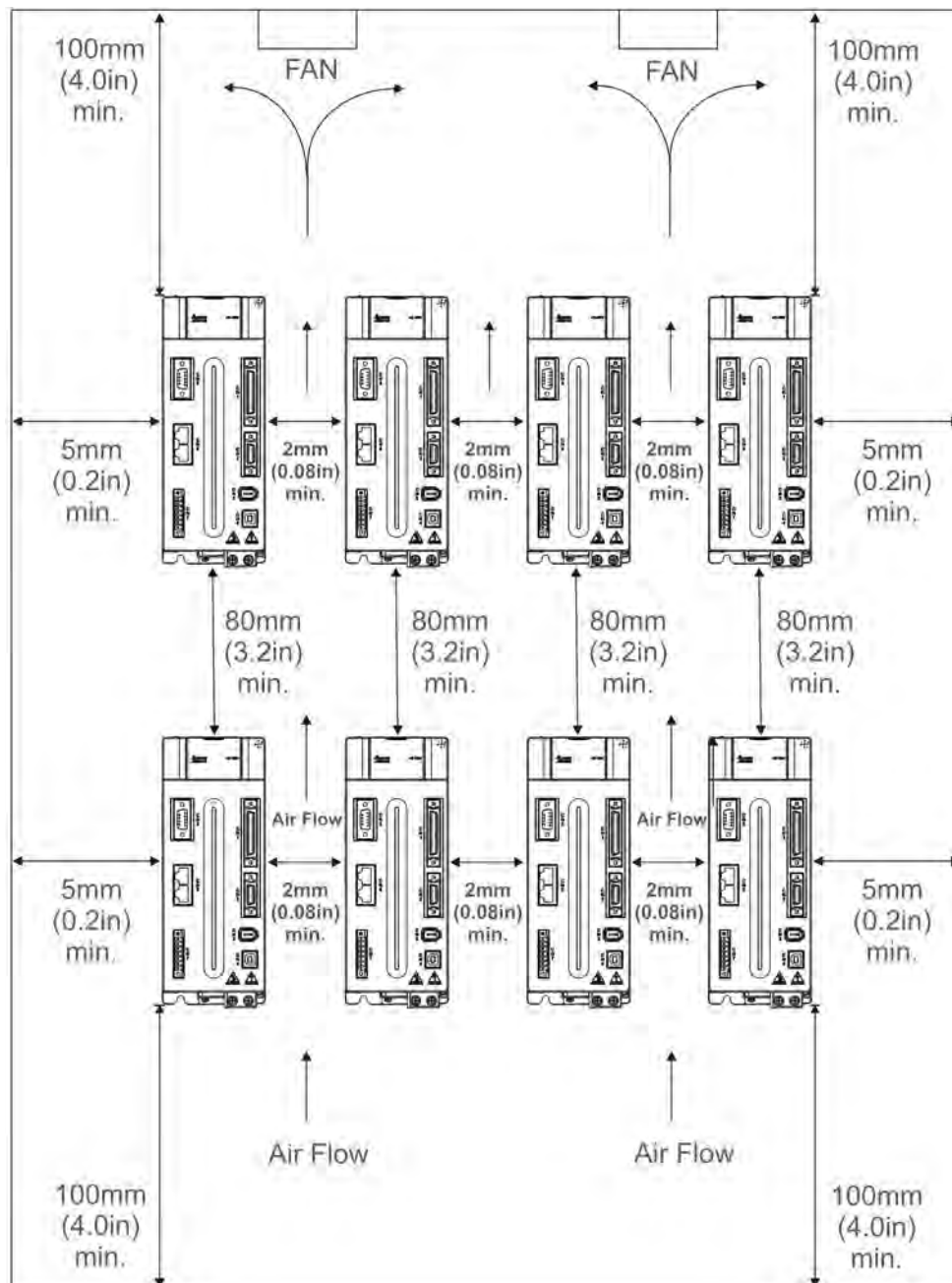


 **NOTE**

The scale of the clearances does not match the dimensions as shown in the drawing above. In the event of any discrepancy between the clearances and the dimensions, the dimensions shall prevail.

■ Side by Side Installation

750W ~ 1.5kW models:

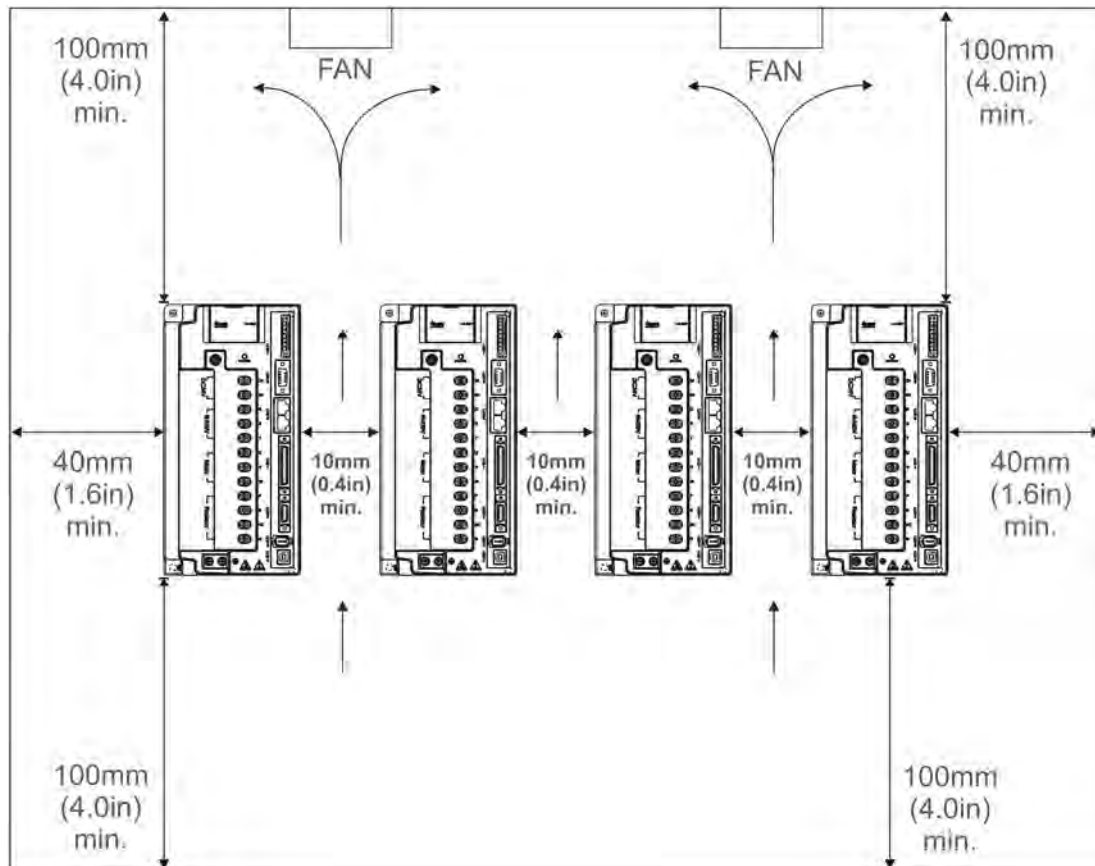


NOTE

The scale of the clearances does not match the dimensions as shown in the drawing above. In the event of any discrepancy between the clearances and the dimensions, the dimensions shall prevail.

ASDA-A2**Chapter 2 Installation and Storage**

2kW ~ 5.5kW models:

**NOTE**

The scale of the clearances does not match the dimensions as shown in the drawing above. In the event of any discrepancy between the clearances and the dimensions, the dimensions shall prevail.

2.5 Circuit Interrupter and Fuse Current Recommended Value



➤ **Caution:** Please use circuit interrupter and fuse which are recognized by and comply with the UL or CSA standards.

220V Series

Servo Drive Model	Recommended Breaker	Recommended Fuse (Class T)
Operation Mode	General	General
ASD-A2-0121-□	5A	5A
ASD-A2-0221-□	5A	5A
ASD-A2-0421-□	10A	10A
ASD-A2-0721-□	10A	20A
ASD-A2-1021-□	15A	25A
ASD-A2-1521-□	20A	40A
ASD-A2-2023-□	30A	50A
ASD-A2-3023-□	30A	70A
ASD-A2-4523-□	70A	140A
ASD-A2-5523-□	75A	150A
ASD-A2-7523-□	95A	175A

400V Series

Servo Drive Model	Recommended Breaker	Recommended Fuse (Class T)
Operation Mode	General	General
ASD-A2-0743-□	10A	20A
ASD-A2-1043-□	15A	25A
ASD-A2-1543-□	20A	40A
ASD-A2-2043-□	30A	50A
ASD-A2-3043-□	30A	70A
ASD-A2-4543-□	70A	140A
ASD-A2-5543-□	75A	150A
ASD-A2-7543-□	95A	175A

NOTE

When using a GFCI (Ground Fault Circuit Interrupter), select a current sensor with sensitivity of equal to or more than 200mA, and not less than 0.1-second detection time to avoid nuisance tripping.

2.6 EMI Filter Selection

AC Servo Drive - EMI Filter Cross Reference

220V Series

Item	Power	Servo Drive Model	Recommended EMI Filter	FootPrint
1	100W	ASD-A2-0121-□	08TDT1W4S	N
2	200W	ASD-A2-0221-□	08TDT1W4S	N
3	400W	ASD-A2-0421-□	08TDT1W4S	N
4	750W	ASD-A2-0721-□	11TDT1W4S	N
5	1000W	ASD-A2-1021-□	11TDT1W4S	N
6	1500W	ASD-A2-1521-□	11TDT1W4S	N
7	2000W	ASD-A2-2023-□	20TDT1W4D	N
8	3000W	ASD-A2-3023-□	20TDT1W4D	N
9	4500W	ASD-A2-4523-□	20TDT1W4D	N
10	5500W	ASD-A2-5523-□	RF075M43BA	Y
11	7500W	ASD-A2-7523-□	RF075M43BA	Y

400V Series

Item	Power	Servo Drive Model	Recommended EMI Filter	FootPrint
1	750W	ASD-A2-0743-□	11TDT1W4S	N
2	1000W	ASD-A2-1043-□	11TDT1W4S	N
3	1500W	ASD-A2-1543-□	11TDT1W4S	N
4	2000W	ASD-A2-2043-□	20TDT1W4D	N
5	3000W	ASD-A2-3043-□	20TDT1W4D	N
6	4500W	ASD-A2-4543-□	20TDT1W4D	N
7	5500W	ASD-A2-5543-□	RF075M43BA	Y
8	7500W	ASD-A2-7543-□	RF075M43BA	Y

NOTE

The boxes (□) in the model names are for optional configurations. (Please refer to section 1.2 for model explanation.)

Installation

All electrical equipment, including AC servo drives, will generate high-frequency/low-frequency noise and will interfere with peripheral equipment by radiation or conduction when in operation. By using an EMI filter with correct installation, much of the interference can be eliminated. It is recommended to use Delta's EMI filter to have the best interference elimination performance.

We assure that it can comply with following rules when AC servo drive and EMI filter are installed and wired according to user manual:

- EN61000-6-4 (2001)
- EN61800-3 (2004) PDS of category C2
- EN55011+A2 (2007) Class A Group 1

General Precaution

To ensure the best interference elimination performance when using Delta's EMI filter, please follow the guidelines in this user manual to perform wiring and/or installation. In addition, please also observe the following precautions:

- EMI filter and AC servo drive should be installed on the same metal plate.
- Please install AC servo drive on same footprint with EMI filter or install EMI filter as close as possible to the AC servo drive.
- All wiring should be as short as possible.
- Metal plate should be grounded.
- The cover of EMI filter and AC servo drive or grounding should be fixed on the metal plate and the contact area should be as large as possible.

Choose Suitable Motor Cable and Precautions

Improper installation and choice of motor cable will affect the performance of EMI filter. Be sure to observe the following precautions when selecting motor cable.

- Use the cable with shielding (double shielding is the best).
- The shielding on both ends of the motor cable should be grounded with the minimum length and maximum contact area.
- Remove any paint on metal saddle for good ground contact with the plate and shielding (Please refer to Figure 1 on page B-3).
- The connection between the metal saddle and the shielding on both ends of the motor cable should be correct and well installed. Please refer to Figure 2 on page B-3 for correct wiring method.

Remove any paint on metal saddle for good ground contact with the plate and shielding.

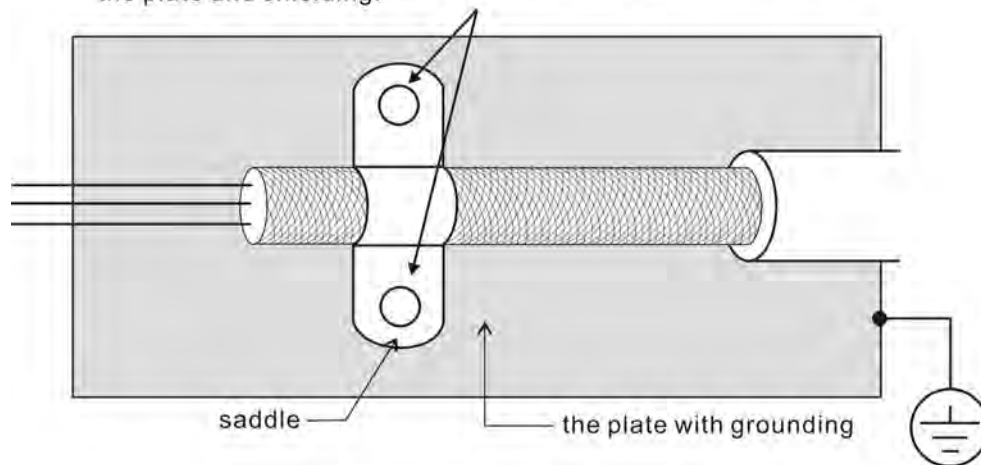
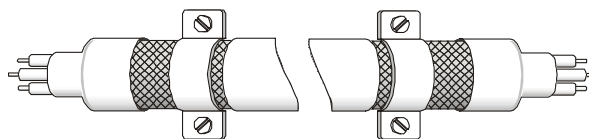
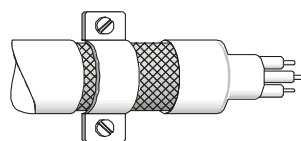


Figure 1



Saddle on both ends

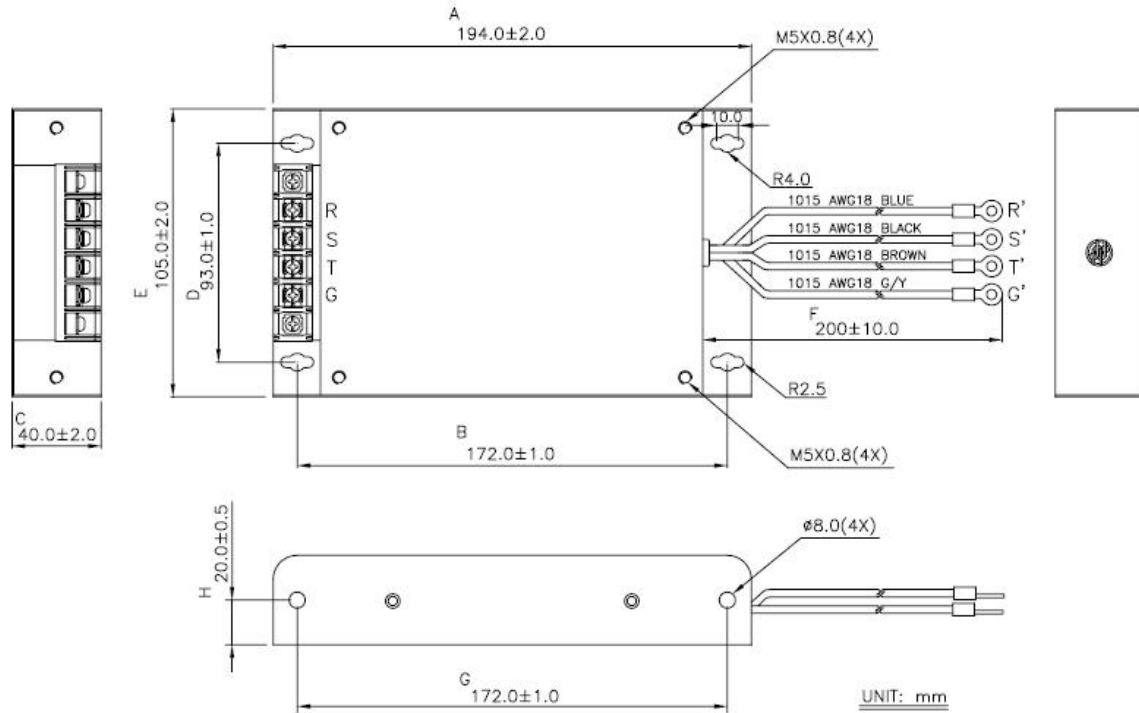


Saddle on one end

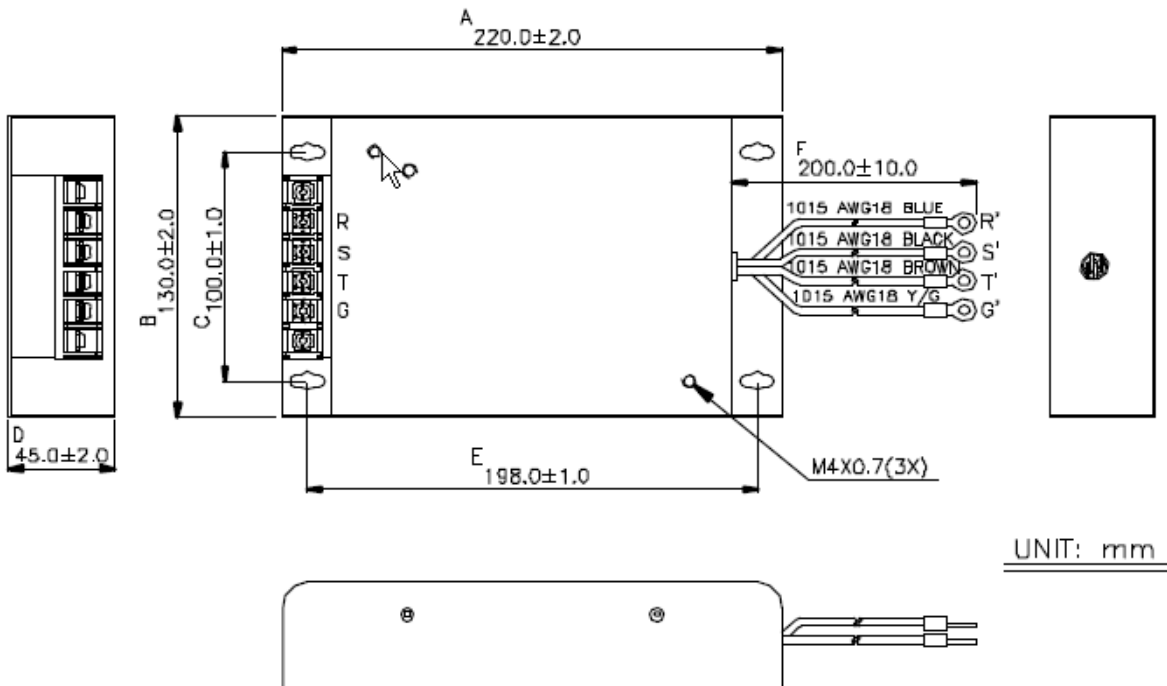
Figure 2

Dimensions

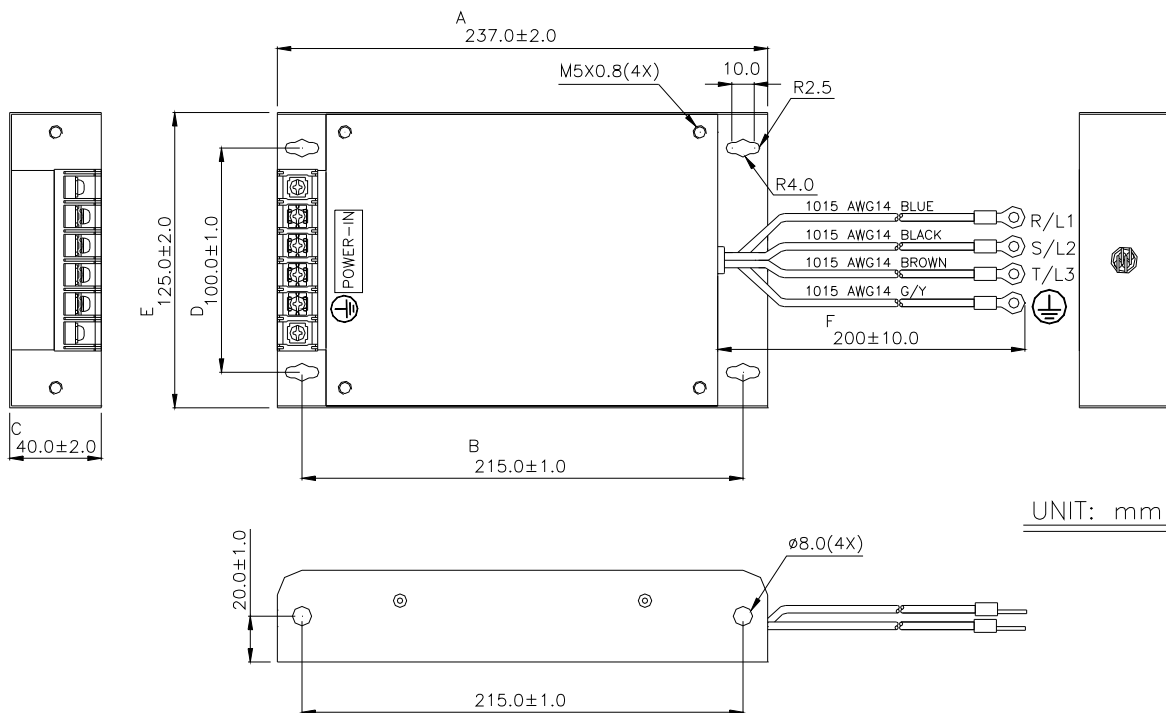
Delta Part Number: 08TDT1W4S



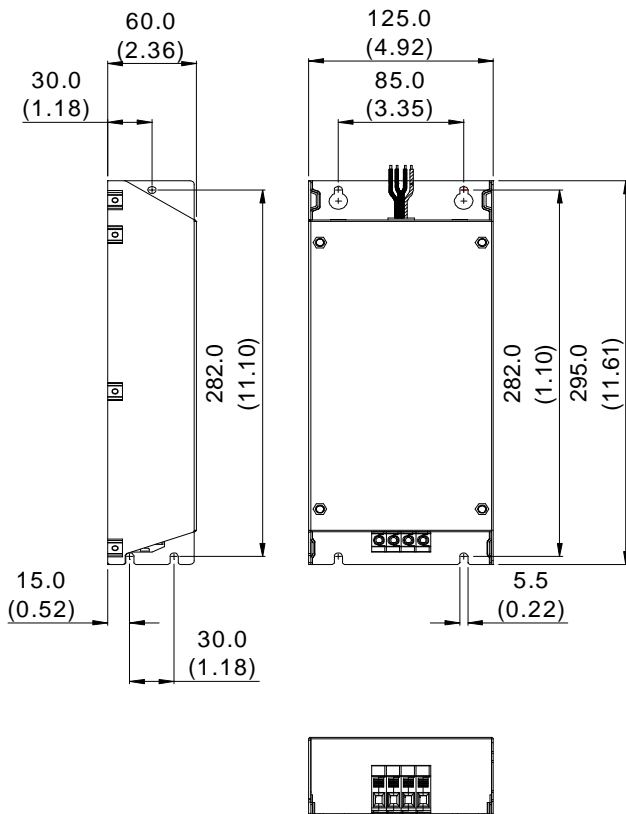
Delta Part Number: 11TDT1W4S



Delta Part Number: 20TDT1W4D



Delta Part Number: RF075M43BA



2.7 Regenerative Resistors

■ Built-in Regenerative Resistor

When the output torque of servo motor in reverse direction of motor rotation speed, it indicates that regenerative power has returned from the load to the servo drive. This power will be transmitted into the capacitance of the DC Bus and result in rising voltage. When the voltage rises too high, the servo system need to dissipate the extra energy by using a regenerative resistor. The ASDA-A2 series servo drive provides a built-in regenerative resistor which is equipped as standard (400W~5.5kW models only). Users can also connect an external regenerative resistor if more regenerative capacity is needed. The following table shows the specifications of the servo drive's built-in regenerative resistor and the amount of regenerative power (average value) that it can process.

220V Series

Specifications of Built-in Regenerative Resistors				
Servo Drive (kW)	Resistance (Ohm) (Parameter P1-52)	Capacity (Watt) (Parameter P1-53)	Regenerative Power processed by built-in regenerative resistor (Watt) *1	Min. Allowable Resistance (Ohm)
0.1	-	-	-	30
0.2	-	-	-	30
0.4	-	-	-	30
0.75	40	60	30	20
1.0	40	60	30	20
1.5	40	60	30	20
2.0	20	100	50	10
3.0	20	100	50	10
4.5	20	100	50	10
5.5	-	-	-	8
7.5	-	-	-	8

400V Series

Specifications of Built-in Regenerative Resistors			
Servo Drive (kW)	Resistance (Ohm) (Parameter P1-52)	Capacity (Watt) (Parameter P1-53)	Min. Allowable Resistance (Ohm)
0.75	80	100	60
1.0	80	100	60
1.5	80	100	40
2.0	-	-	40
3.0	-	-	30
4.5	-	-	20
5.5	-	-	20
7.5	-	-	15

When the regenerative power exceeds the processing capacity of the servo drive, install an external regenerative resistor. Please pay close attention to the following notes when using a regenerative resistor.

1. Make sure the settings of resistance (parameter P1-52) and capacity (parameter P1-53) are set correctly.
2. When installing an external regenerative resistor, make sure that its resistance value is the same as the resistance of the built-in regenerative resistor. If combining multiple small-capacity regenerative resistors in parallel to increase the regenerative resistor capacity, make sure that the resistance value of the regenerative resistor complies with the specifications listed in the table above.
3. In general, when the amount of regenerative power (average value) that can be processed is used at or below the rated load ratio, the resistance temperature will increase to 120°C or higher (when the regeneration occurs continuously). For safety reasons, forced air cooling is a good way to reduce the temperature of the regenerative resistors. We also recommend using regenerative resistors with thermal switches. As for the load characteristics of the regenerative resistors, please check with the manufacturer.

■ External Regenerative Resistor

When using an external regenerative resistor, connect it to P⁺ and C, and make sure the circuit between P⁺ and D is open. We recommend using external regenerative resistors with resistance values that follow the table above (Specifications of Built-in Regenerative Resistors). We ignore the dissipative power of IGBT (Insulated Gate Bipolar Transistor) in order to let the users easily calculate the capacity of regenerative resistor. In the following sections, we will describe Regenerative Power Calculation Method and Simple Calculation Method for calculating the regenerative power capacity of external regenerative resistors.

■ Regenerative Power Calculation Method

(1) Without Load

When there is no external load torque, if the servo motor repeats operation, the returned regenerative power generated when braking will be transmitted into the capacitance of DC bus. After the capacitance voltage exceeds some high value, regenerative resistor can dissipate the remained regenerative power. Use the table and procedure described below to calculate the regenerative power.

220V Series

Servo Drive (kW)		Servo Motor	Rotor Inertia J ($\times 10^{-4}$ kg.m ²)	Regenerative power from empty load 3000r/min to stop Eo (joule)	Max. regenerative power of capacitance Ec (joule)
Low Inertia	0.1	ECMA-C10402□□	0.037	0.18	3
	0.2	ECMA-C10602□□	0.177	0.87	4
	0.4	ECMA-C10604□□	0.277	1.37	8
		ECMA-C10804□□	0.68	3.36	
	0.75	ECMA-C10807□□	1.13	5.59	14
	1.0	ECMA-C11010□□	2.65	13.1	18
	2.0	ECMA-C11020□□	4.45	22.0	21
Medium Inertia	0.4	ECMA-E11305□□	8.17	40.40	8
	1.0	ECMA-E11310□□	8.41	41.59	18
	1.5	ECMA-E11315□□	11.18	55.28	18
	2.0	ECMA-E11320□□	14.59	72.15	21
		ECMA-E11820□□	34.68	171.50	
3.0	ECMA-F11830□□	54.95	217.73	28	
Medium- High Inertia	3.0	ECMA-F11830□□	54.95	217.73	28
	4.5	ECMA-F11845□□	77.75	384.47	25
	5.5	ECMA-F11855□□	99.78	493.40	27
	7.5	ECMA-F11875□□	142.7	705.66	93
High Inertia	0.4	ECMA-G11303□□	8.17	40.40	8
	0.75	ECMA-G11306□□	8.41	41.59	14
	1.0	ECMA-G11309□□	11.18	55.29	18

$E_o = J \times \omega r^2 / 182$ (joule) , W_r : r/min

400V Series

Servo Drive (kW)		Servo Motor	Rotor Inertia J ($\times 10^{-4}$ kg.m ²)	Regenerative power from empty load 3000r/min to stop Eo (joule)	Max. regenerative power of capacitance Ec (joule)
Low Inertia	0.75	ECMA-J10807□□	1.13	5.59	42.43
Medium Inertia	1.0	ECMA-K11310□□	8.41	18.48	51.17
	1.5	ECMA-K11315□□	11.18	24.57	57.41
	2.0	ECMA-K11320□□	14.59	18.04	34.94
Medium- High Inertia	3.0	ECMA-L11830□□	54.95	67.93	42.43
	4.5	ECMA-L11845□□	77.75	96.12	51.17
	5.5	ECMA-L11855□□	99.78	123.35	57.41
	7.5	ECMA-L11875□□	142.7	176.41	62.40

$E_o = J \times \omega r^2 / 182$ (joule) , W_r : r/min

If the load inertia is $N \times$ motor inertia, the regenerative power will be $(N+1) \times E_0$ when servo motor brakes from 3000r/min to 0. Then, the regenerative resistor can dissipate: $(N+1) \times E_0 - E_c$ (joule). If the time of repeat operation cycle is T sec, then the regenerative power = $2 \times ((N+1) \times E_0 - E_c) / T$. The calculating procedure is as follows:

Step	Procedure	Equation and Setting Method
1	Set the capacity of regenerative resistor to the maximum	Change the value of P1-53 to maximum
2	Set the operation cycle T	Input by the users
3	Set motor speed W_r	Input by the users or read via P0-02 Drive State Display
4	Set load/motor inertia ratio N	Input by the users or read via P0-02 Drive State Display
5	Calculate the max. regenerative power E_0	$E_0 = J \times w_r^2 / 182$
6	Set the regenerative power E_c that can be absorbed	Refer to the table above
7	Calculate the required regenerative power capacity	$2 \times (N+1) \times E_0 - E_c / T$

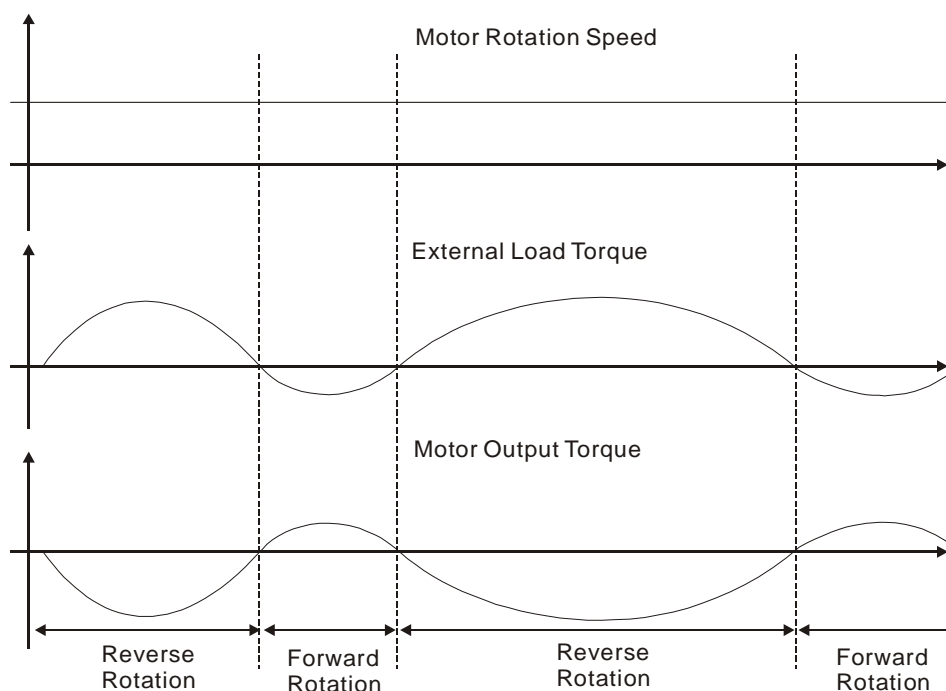
For example:

If we use 400W servo drive, the time of repeat operation cycle is $T = 0.4$ sec, max. motor speed is 3000r/min, the load inertia = $7 \times$ motor inertia, then the necessary the power of regenerative resistor = $2 \times ((7+1) \times 1.68 - 8) / 0.4 = 27.2W$. If the calculation result is smaller than regenerative power, we recommend the users to use the built-in 60W regenerative resistor. Usually the built-in regenerative resistor provided by ASDA-A2 series servo drives can meet the requirement of general application when the external load inertia is not excessive.

The users can see when the capacity of regenerative resistor is too small, the accumulated power will be larger and the temperature will also increase. The fault, AL005 may occur if the temperature is over high. The following figure shows the actual operation of regenerative resistor.

(2) With Load

When there is an external load torque, servo motor is in reverse rotation when external load greater than motor torque. Servo motor is usually in forward rotation and the motor torque output direction is the same as the rotation direction. However, there is still some special condition. If the motor output torque is in the reverse direction of rotation, the servo motor is also in the reverse direction of rotation. The external power is input into the servo drive through servo motor. The Figure 6.21 below is an example. The users can see the motor is in forward rotation at constant speed when a sudden external load torque change and great power is transmitted to regenerative resistor rapidly.



External load torque in reverse direction: $T_L \times W_r$ T_L : External load torque

For the safety, we strongly recommend the users should select the proper resistance value according to the load.

For example:

When external load torque is a +70% rated torque and rotation speed reaches 3000r/min, if using 400W servo drive (rated torque: 1.27Nt-m), then the users need to connect a external regenerative resistor which power is $2 \times (0.7 \times 1.27) \times (3000 \times 2 \times \pi / 60) = 560W, 40\Omega$.

■ Simple Calculation Method

The users can select the adequate regenerative resistors according to the allowable frequency required by actual operation and the allowable frequency when the servo motor runs without load. The allowable frequency when the servo motor run without load is the maximum frequency that can be operated during continuous operation when servo motor accelerate from 0r/min to rated speed and decelerate from rated speed down to 0r/min. The allowable frequencies when the servo motor run without load are summarized in the following table.

Allowable frequency when the servo motor runs without load (times/min) and uses a built-in regenerative resistor											
Motor Capacity	600W	750W	900W	1.0kW	1.5kW	2.0kW	2.0kW	3.0kW	4.5kW	5.5kW	7.5kW
Servo Motor	06	07	09	10	15	20	20	30	45	55	75
ECMA□□C	-	312	-	137	-	83 (F100)	-	-	-	-	-
ECMA□□E	-	-	-	42	32	24 (F130)	10 (F180)	11	-	-	-

Allowable frequency when the servo motor runs without load (times/min) and uses a built-in regenerative resistor											
Motor Capacity	600W	750W	900W	1.0kW	1.5kW	2.0kW	2.0kW	3.0kW	4.5kW	5.5kW	7.5kW
Servo Motor	06	07	09	10	15	20	20	30	45	55	75
ECMA□□F	-	-	-	-	-	-	-	11	8	-	-
ECMA□□G	42	-	31	-	-	-	-	-	-	-	-
ECMA□□J	-	537	-	-	-	-	-	-	-	-	-
ECMA□□K	-	-	-	162	122	-	-	-	-	-	-
ECMA□□L	-	-	-	-	-	-	-	-	-	-	-

When the servo motor runs with load, the allowable frequency will change according to the changes of the load inertia and rotation speed. Use the following equation to calculate the allowable frequency.

$$\text{Allowable frequency} = \frac{\text{Allowable frequency when servo motor run without load}}{m + 1} \times \left(\frac{\text{Rated speed}}{\text{Operating speed}} \right)^2 \frac{\text{times}}{\text{min.}}$$

m = load/motor inertia ratio

The users can select the adequate external regenerative resistors according to the allowable frequency by referring to the table below:

Allowable frequency when the servo motor run without load (times/min) and uses external regenerative resistor							
Recommended Regenerative Resistor Specifications	Motor Capacity	ECMA□□C					
	100W	200W	400W (F60)	400W (F80)	750W	1.0kW	2.0kW
	01	02	04	04	07	10	20
BR400W040 (400W 40Ω)	-	-	8608	3506	2110	925	562
BR1K0W020 (1kW 20Ω)	-	-	-	8765	5274	2312	1406
Recommended Regenerative Resistor Specifications	Motor Capacity	ECMA□□E					
	0.5kW	1kW	1.5kW	2.0kW (F130)	2.0kW (F180)	3.0kW	
	05	1.0	15	20	20	30	
BR400W040 (400W 40Ω)	291	283	213	163	68	-	
BR1K0W020 (1kW 20Ω)	729	708	533	408	171	-	
BR1K5W005 (3kW 10Ω)	-	-	-	-	-	331	
Recommended Regenerative Resistor Specifications	Motor Capacity	ECMA□□F					
	3.0kW	4.5kW	5.5kW	7.5kW			
	30	45	55	75			
BR1K5W005 (3kW 10Ω)	331	234	182	127			

Allowable frequency when the servo motor run without load (times/min) and uses external regenerative resistor					
Recommended Regenerative Resistor Specifications	Motor Capacity	ECMA□□G			
		0.3kW	0.6kW	0.9kW	
		03	06	09	
	BR400W040 (400W 40Ω)	292	283	213	
	BR1K0W020 (1kW 20Ω)	729	708	533	
Recommended Regenerative Resistor Specifications	Motor Capacity	ECMA□□K			
		1.0kW	1.5kW	2.0kW	
		10	15	20	
	BR400W040 (400W 40Ω)	-	488	665	
Recommended Regenerative Resistor Specifications	Motor Capacity	ECMA□□L			
		3.0kW	4.5kW	5.5kW	7.5kW
		30	45	55	75
	BR400W040 (400W 40Ω)	177	-	-	-
	BR1K0W020 (1kW 20Ω)	-	312	243	170

When the regenerative resistor capacity is not enough, the users can connect to multiple the same capacity regenerative resistors in parallel to increase it.

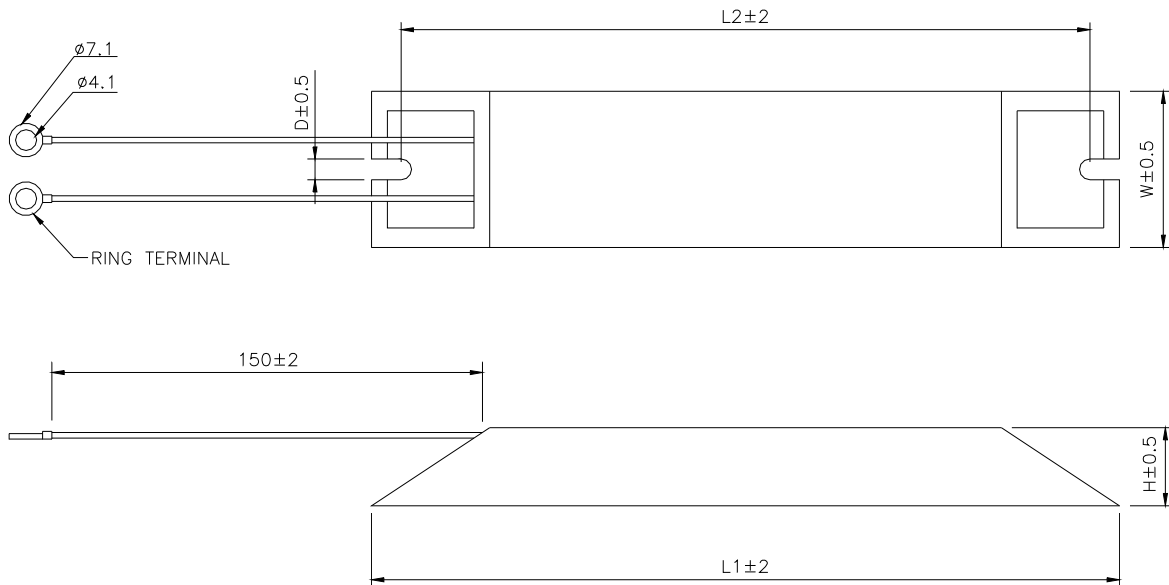
ASDA-A2

Chapter 2 Installation and Storage

Dimensions

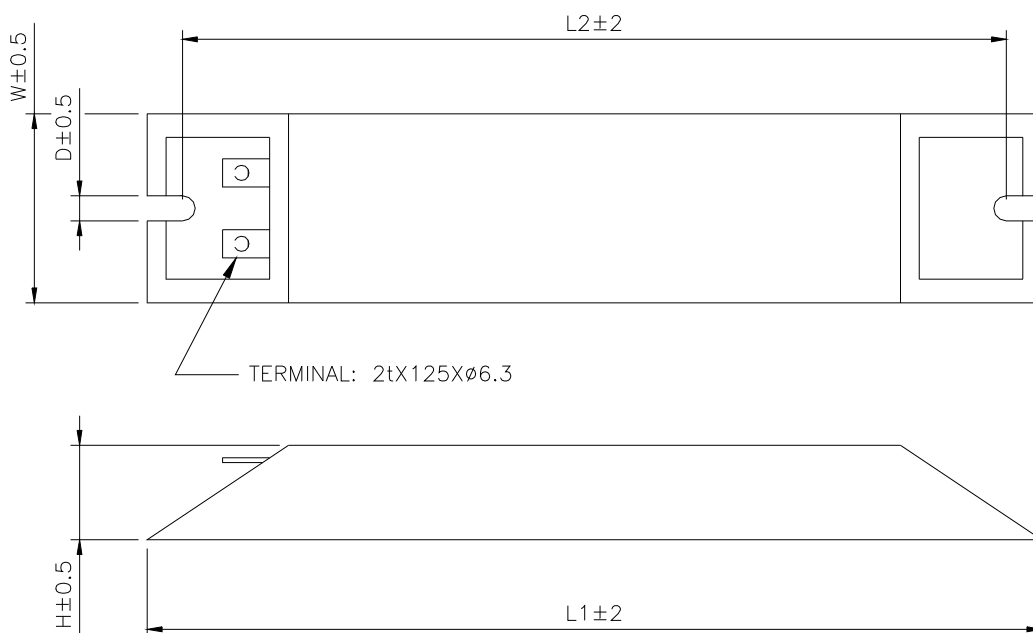
Delta Part Number : BR400W040 (400W 40Ω)

L1	L2	H	D	W	MAX. WEIGHT(g)
265	250	30	5.3	60	930

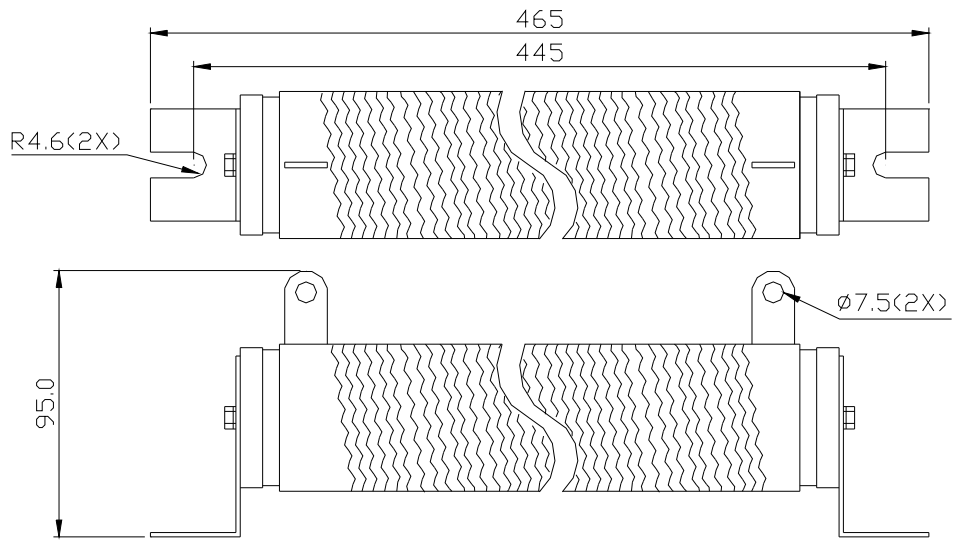


Delta Part Number : BR1K0W020 (1kW 20Ω)

L1	L2	H	D	W	MAX. WEIGHT(g)
400	385	50	5.3	100	2800



Delta Part Number : BR1K5W005 (3kW 10Ω)



This page intentionally left blank

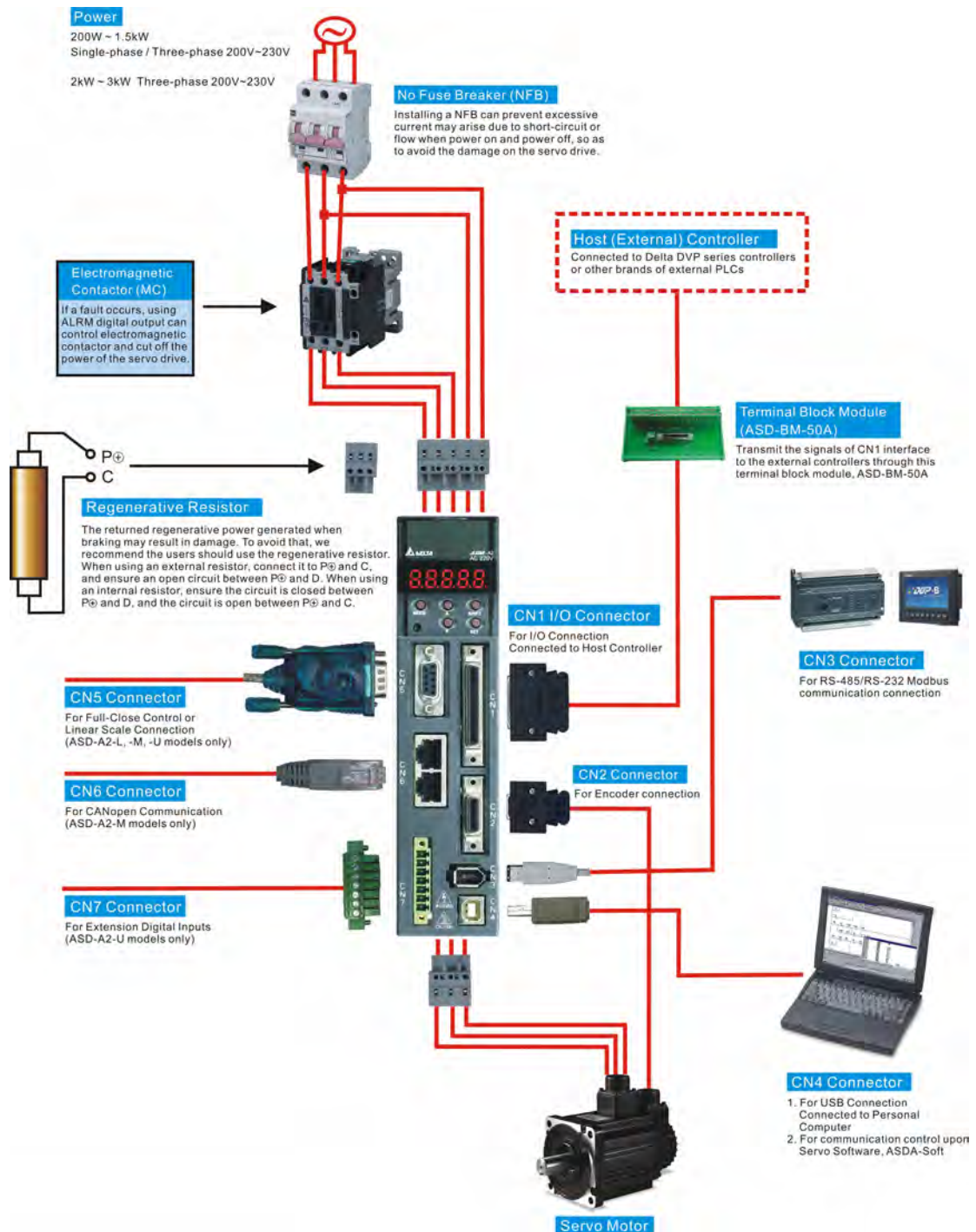
Chapter 3 Connections and Wiring

This chapter provides information on wiring ASDA-A2 series products, the descriptions of I/O signals and gives typical examples of wiring diagrams.

3.1 Connections - 220V series

3.1.1 Connecting to Peripheral Devices

Figure 3.1 Configuration



3.1.2 Servo Drive Connectors and Terminals

Terminal Identification	Terminal Description	Notes		
L1c, L2c	Control circuit terminal	Used to connect single-phase AC control circuit power depending on connecting servo drive model.		
R, S, T	Main circuit terminal	Used to connect three-phase AC main circuit power depending on connecting servo drive model.		
U, V, W FG (⊕)	Servo motor output	Used to connect servo motor		
		Terminal Symbol	Wire Color	Description
		U	Red	Connecting to three-phase motor main circuit cable.
		V	White	
		W	Black	
FG(⊕)	Green	Connecting to ground terminal (⊕) of the servo drive.		
P⊕, D, C, ⊖	Regenerative resistor terminal or braking unit	Internal resistor	Ensure the circuit is closed between P⊕ and D, and the circuit is open between P⊕ and C.	
		External resistor	Connect regenerative resistor to P⊕ and C, and ensure an open circuit between P⊕ and D.	
		External braking unit	Connect braking unit to P⊕ and ⊖, and ensure an open circuit between P⊕ and D, and P⊕ and C. (N terminal is built in L1C, L2C, ⊖, and R, S, T.) P⊕ : Connecting to (+) terminal of V_BUS voltage. ⊖ : Connecting to (-) terminal of V_BUS voltage.	
⊕ two places	Ground terminal	Used to connect grounding wire of power supply and servo motor.		
CN1	I/O connector (Optional Part)	Used to connect external controllers. Please refer to section 3.3 for details.		
CN2	Encoder connector (Optional Part)	Used to connect encoder of servo motor. Please refer to section 3.4 for details.		
		Terminal Symbol	Wire Color	Pin No.
		T+	Blue	5
		T-	Blue/Black	4
		Reserved	-	-
		Reserved	-	-
		+5V	Red & Red/White	14, 16
GND	Black & Black/White	13, 15		

Terminal Identification	Terminal Description	Notes
CN3	Communication connector (Optional Part)	Used for RS-485 or RS-232 communication connection. Please refer to section 3.5 for details.
CN4	USB connector (Type B) (Optional Part)	Used to connect personal computer (PC or notebook). Please refer to section 3.6 for details.
CN5	Position feedback signal connector (for full-closed loop) (Optional Part)	Used to connect to linear scale or encoder to constitute a full-closed loop. Please refer to section 3.7 for details.
CN6	CANopen communication port (Optional Part)	RJ45 connector, used for CANopen communication. Please refer to section 3.8 for details.
CN7	Extension digital input terminal (Optional Part)	Used to connect to extension digital inputs. Please refer to section 3.9 for details.
CN8	Reserved connector	Reserved
CN9	Communication extension connector (Optional Part)	Used to connect to other extension cards (will be available soon).

Wiring Notes

Please observe the following wiring notes while performing wiring and touching any electrical connections on the servo drive or servo motor.

1. Ensure to check if the power supply and wiring of the "power" terminals (R, S, T, L1C, L2C, U, V, & W) is correct.
2. Please use shielded twisted-pair cables for wiring to prevent voltage coupling and eliminate electrical noise and interference.
3. As a residual hazardous voltage may remain inside the drive, please do not immediately touch any of the "power" terminals (R, S, T, L1C, L2C, U, V, & W) and/or the cables connected to them after the power has been turned off and the charge LED is lit. (Please refer to the Safety Precautions on page ii).
4. The cables connected to R, S, T and U, V, W terminals should be placed in separate conduits from the encoder or other signal cables. Separate them by at least 30cm (11.8 inches).
5. If the encoder cable (CN2) or the cable for position feedback signal connector (CN5) is too short, please use a twisted-shield signal wire with grounding conductor. The wire length should be 20m (65.62ft.) or less. For lengths greater than 20m (65.62ft.), the wire gauge should be doubled in order to lessen any signal

attenuation. For the encoder cable specification, please use AWG26 wire size and the Metal braided shield twisted-pair cable which meets the UL2464 specification.

6. When using CANopen communication, please use the shielded twisted-pair cables to ensure the communication quality.
7. The shield of shielded twisted-pair cables should be connected to the SHIELD end (terminal marked \oplus) of the servo drive.
8. For the connectors and cables specifications, please refer to section 3.1.6 for details.

3.1.3 Wiring Methods

For servo drives from 200W to 1.5kW the input power can be either single or three-phase. However, single -phase connections are for servo drives 1.5kW and below only.

In the wiring diagram figures 3.2 & 3.3:

Power ON : contact "a" (normally open)

Power OFF /ALRM_RY : contact "b" (normally closed)

MC : coil of electromagnetic contactor, self-holding power, contact of main circuit power

Figure 3.2 Single-Phase Power Supply Connection (for 1.5kW and below models)

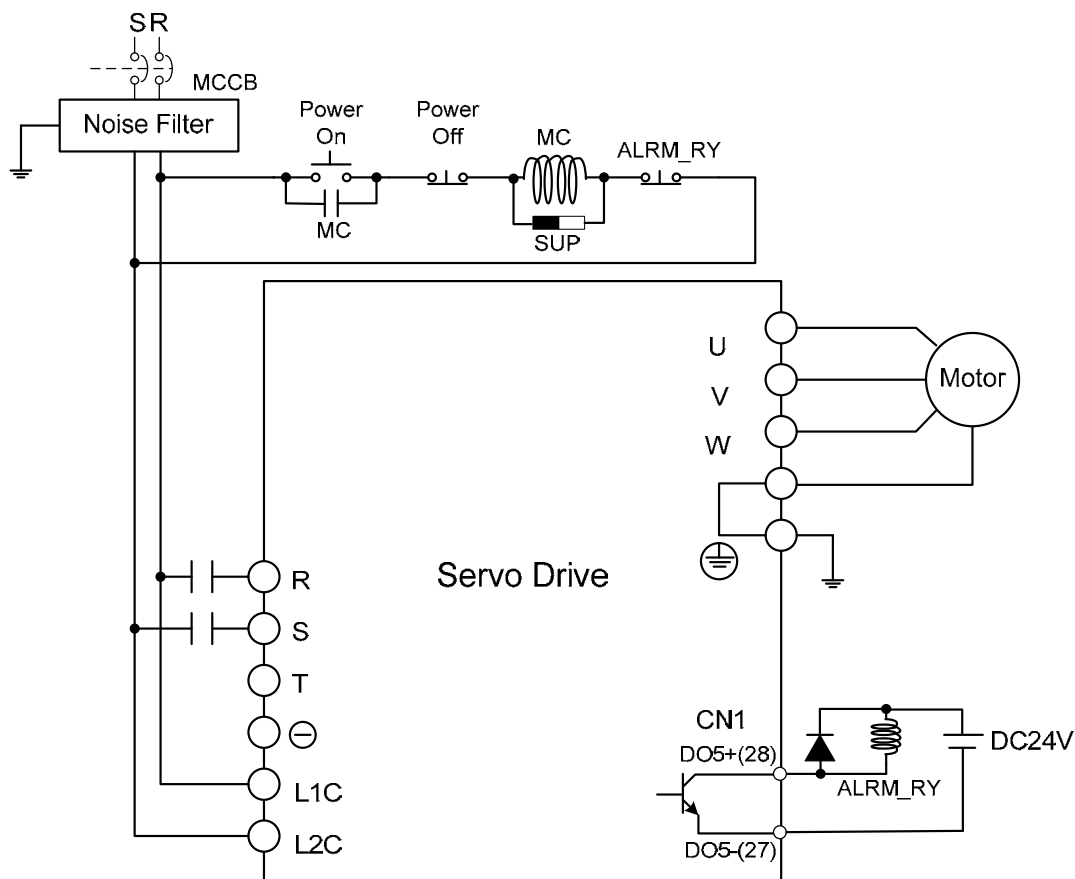
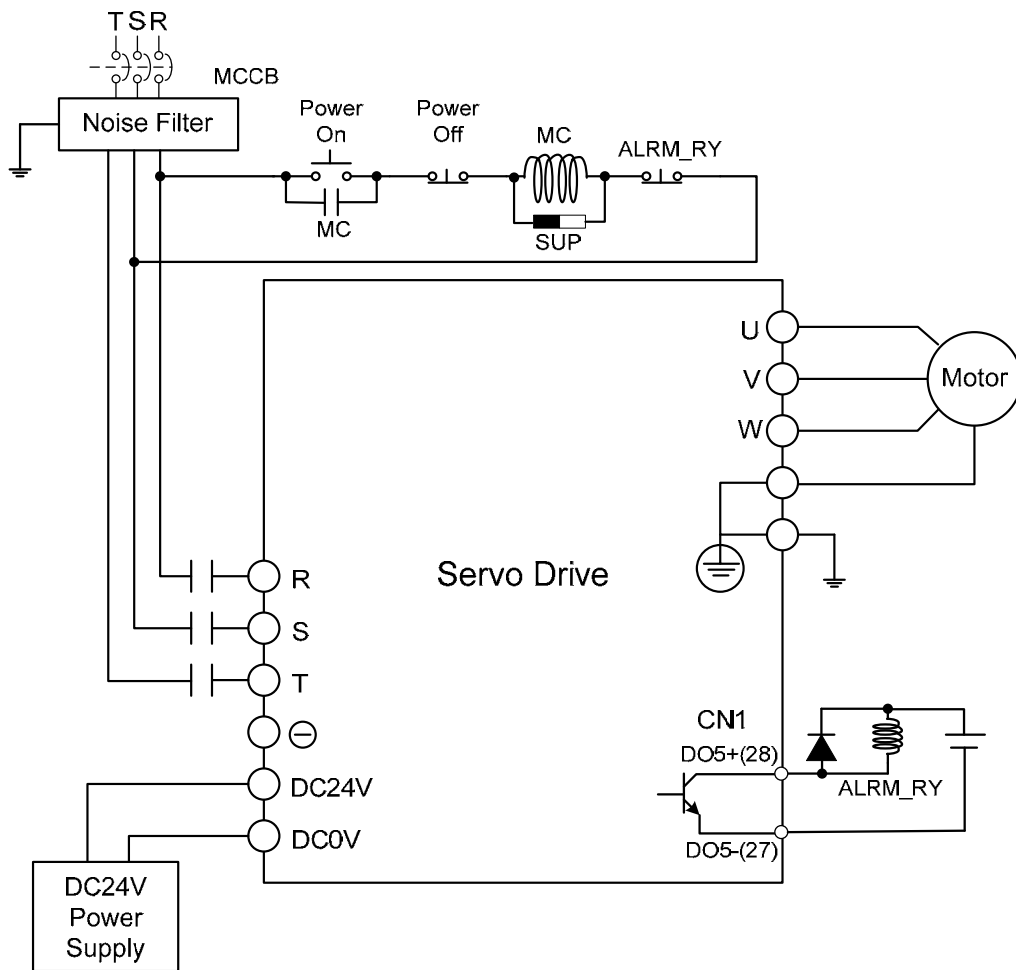
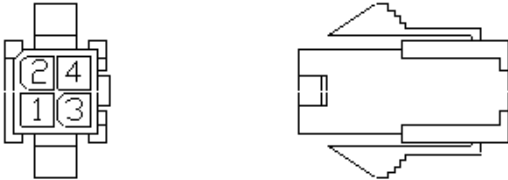
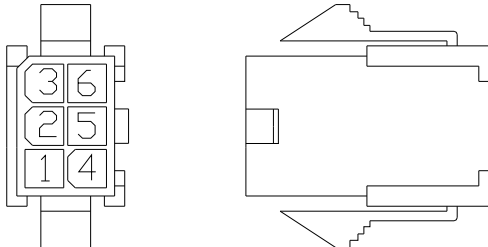
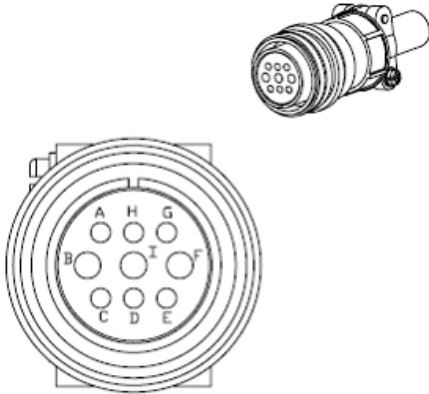
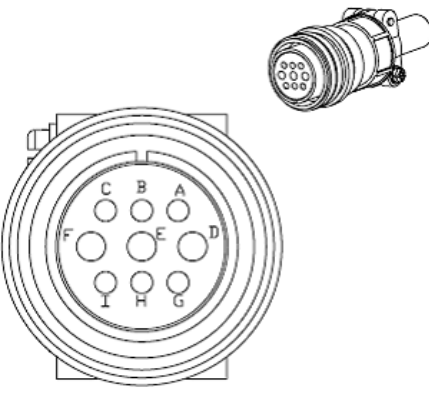


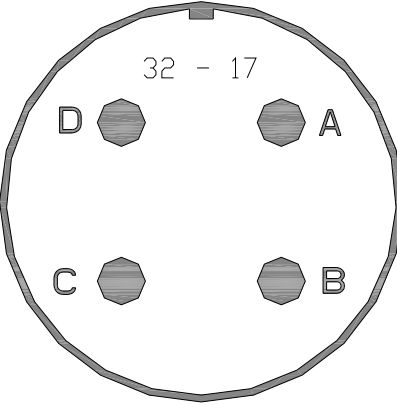
Figure 3.3 Three-Phase Power Supply Connection (for all models)




3.1.4 Motor Power Cable Connector Specifications

The boxes (□) in the model names are for optional configurations. (Please refer to section 1.2 for model explanation.)

Motor Model Name	U, V, W / Electromagnetic Brake Connector	Terminal Identification
ECMA-C10401□S (100W) ECMA-C10602□S (200W) ECMA-C10604□S (400W) ECMA-C10804□7 (400W) ECMA-C10807□S (750W)	 <p>HOUSING: JOWLE (C4201H00-2*2PA)</p>	A
ECMA-C10401□S (100W) ECMA-C10602□S (200W) ECMA-C10604□S (400W) ECMA-C10804□7 (400W) ECMA-C10807□S (750W) *□ : with brake	 <p>HOUSING : JOWLE (C4201H00-2*3PA)</p>	B
ECMA-G11303□S (300W) ECMA-E11305□S (500W) ECMA-G11306□S (600W) ECMA-G11309□S (900W) ECMA-C11010□S (1000W) ECMA-E11310□S (1000W) ECMA-E11315□S (1500W) ECMA-C11020□S (2000W) ECMA-E11320□S (2000W)	 <p>3106A-20-18S</p>	C
ECMA-E11820□S (2000W) ECMA-E11830□S (3000W) ECMA-F11830□S (3000W) ECMA-F11845□S (4500W) ECMA-F11855□3 (5500W)	 <p>3106A-24-11S</p>	D

Motor Model Name	U, V, W / Electromagnetic Brake Connector	Terminal Identification
ECMA-F11855□3 (5500W) ECMA-F11875□3 (7500W)		E

Motor Model Name	U, V, W / Electromagnetic Brake Connector	Terminal Identification
ECMA-F21855□3(5500W) ECMA-F21875□3(7500W)		F

Terminal Identification	U (Red)	V (White)	W (Black)	CASE GROUND (Green)	BRAKE1 (Yellow)	BRAKE2 (Blue)
A	1	2	3	4	-	-
B	1	2	4	5	3	6
C	F	I	B	E	G	H
D	D	E	F	G	A	B
E	A	B	C	D	-	-

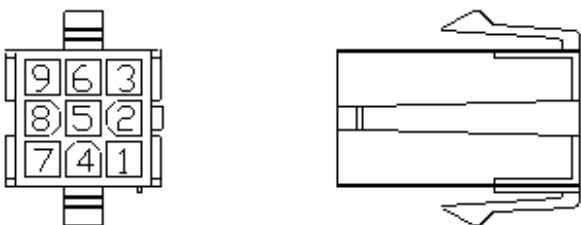
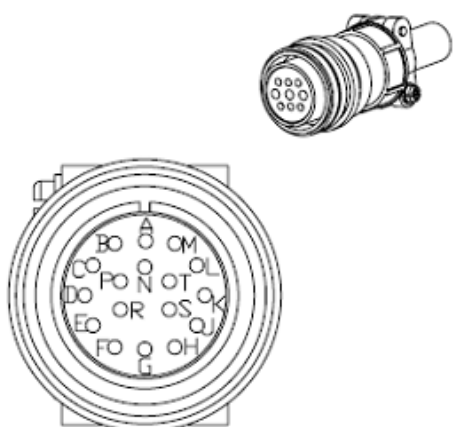
Terminal Identification	BRAKE1	BRAKE2
F	A	B

 **NOTE**

- 1) The coil of brake has no polarity. The names of terminal identification are BRAKE1 (Yellow) and BRAKE2 (Blue).
- 2) The power supply for brake is DC24V. Never use it for VDD, the +24V source voltage.

3.1.5 Encoder Connector Specifications

The boxes (□) in the model names are for optional configurations. (Please refer to section 1.2 for model explanation.)

Motor Model Name	Encoder Connector	Terminal Identification
ECMA-C10401□S (100W) ECMA-C10602□S (200W) ECMA-C10604□S (400W) ECMA-C10804□7 (400W) ECMA-C10807□S (750W)	 <p>HOUSING : AMP (1-172161-9)</p>	A
ECMA-G11303□S (300W) ECMA-E11305□S (500W) ECMA-G11306□S (600W) ECMA-G11309□S (900W) ECMA-C11010□S (1000W) ECMA-E11310□S (1000W) ECMA-E11315□S (1500W) ECMA-C11020□S (2000W) ECMA-E11320□S (2000W) ECMA-E11820□S (2000W) ECMA-E11830□S (3000W) ECMA-F11830□S (3000W) ECMA-F11845□S (4500W) ECMA-F11855□3 (5500W) ECMA-F11875□3 (7500W)	 <p>3106A-20-29S</p>	B

Terminal Identification	T+	T-	Reserved	Reserved	Reserved	Reserved	DC+5V	GND	BRAID SIELD
A	1 (Blue)	4 (Blue/ Black)	-	-	-	-	7 (Red & Red/White)	8 (Black & Black/White)	9
B	A	B	-	-	-	-	S	R	L

3.1.6 Cable Specifications for Servo Drive**Power Cable**

Servo Drive and Servo Motor		Power Cable - Wire Gauge AWG (mm ²)			
		L1C, L2C	R, S, T	U, V, W	P ⁺ , C
ASD-A2-0121-□	ECMA-C10401□S	1.3 (AWG16)	2.1 (AWG14)	0.82 (AWG18)	2.1 (AWG14)
ASD-A2-0221-□	ECMA-C10602□S	1.3 (AWG16)	2.1 (AWG14)	0.82 (AWG18)	2.1 (AWG14)
ASD-A2-0421-□	ECMA-C10604□S	1.3 (AWG16)	2.1 (AWG14)	0.82 (AWG18)	2.1 (AWG14)
	ECMA-C10804□7	1.3 (AWG16)	2.1 (AWG14)	0.82 (AWG18)	2.1 (AWG14)
	ECMA-E11305□S	1.3 (AWG16)	2.1 (AWG14)	0.82 (AWG18)	2.1 (AWG14)
	ECMA-G11303□S	1.3 (AWG16)	2.1 (AWG14)	0.82 (AWG18)	2.1 (AWG14)
ASD-A2-0721-□	ECMA-C10807□S	1.3 (AWG16)	2.1 (AWG14)	0.82 (AWG18)	2.1 (AWG14)
	ECMA-G11306□S	1.3 (AWG16)	2.1 (AWG14)	0.82 (AWG18)	2.1 (AWG14)
ASD-A2-1021-□	ECMA-C11010□S	1.3 (AWG16)	2.1 (AWG14)	1.3 (AWG16)	2.1 (AWG14)
	ECMA-E11310□S	1.3 (AWG16)	2.1 (AWG14)	1.3 (AWG16)	2.1 (AWG14)
	ECMA-G11309□S	1.3 (AWG16)	2.1 (AWG14)	1.3 (AWG16)	2.1 (AWG14)
ASD-A2-1521-□	ECMA-E11315□S	1.3 (AWG16)	2.1 (AWG14)	1.3 (AWG16)	2.1 (AWG14)
ASD-A2-2023-□	ECMA-C11020□S	1.3 (AWG16)	2.1 (AWG14)	2.1 (AWG14)	2.1 (AWG14)
	ECMA-E11320□S	1.3 (AWG16)	2.1 (AWG14)	2.1 (AWG14)	2.1 (AWG14)
	ECMA-E11820□S	1.3 (AWG16)	2.1 (AWG14)	3.3 (AWG12)	2.1 (AWG14)
ASD-A2-3023-□	ECMA-E11830□S	1.3 (AWG16)	2.1 (AWG14)	3.3 (AWG12)	2.1 (AWG14)
	ECMA-F11830□S	1.3 (AWG16)	2.1 (AWG14)	3.3 (AWG12)	2.1 (AWG14)
ASD-A2-4523-□	ECMA-F11845□S	1.3 (AWG16)	3.3 (AWG12)	8.4 (AWG8)	3.3 (AWG12)
ASD-A2-5523-□	ECMA-F11855□3	1.3 (AWG16)	3.3 (AWG12)	13.3 (AWG6)	3.3 (AWG12)
ASD-A2-7523-□	ECMA-F11875□3	1.3 (AWG16)	5.3 (AWG10)	13.3 (AWG6)	3.3 (AWG12)

Encoder Cable

Servo Drive	Encoder Cable - Wire Gauge AWG (mm ²)			
	Wire Size	Wire Size	Wire Size	Wire Size
ASD-A2-0121-□	0.13 (AWG26)	10 core (4 pair)	UL2464	3m (9.84ft.)
ASD-A2-0221-□	0.13 (AWG26)	10 core (4 pair)	UL2464	3m (9.84ft.)
ASD-A2-0421-□	0.13 (AWG26)	10 core (4 pair)	UL2464	3m (9.84ft.)
ASD-A2-0721-□	0.13 (AWG26)	10 core (4 pair)	UL2464	3m (9.84ft.)
ASD-A2-1021-□	0.13 (AWG26)	10 core (4 pair)	UL2464	3m (9.84ft.)
ASD-A2-1521-□	0.13 (AWG26)	10 core (4 pair)	UL2464	3m (9.84ft.)
ASD-A2-2023-□	0.13 (AWG26)	10 core (4 pair)	UL2464	3m (9.84ft.)
ASD-A2-3023-□	0.13 (AWG26)	10 core (4 pair)	UL2464	3m (9.84ft.)
ASD-A2-4523-□	0.13 (AWG26)	10 core (4 pair)	UL2464	3m (9.84ft.)
ASD-A2-5523-□	0.13 (AWG26)	10 core (4 pair)	UL2464	3m (9.84ft.)
ASD-A2-7523-□	0.13 (AWG26)	10 core (4 pair)	UL2464	3m (9.84ft.)

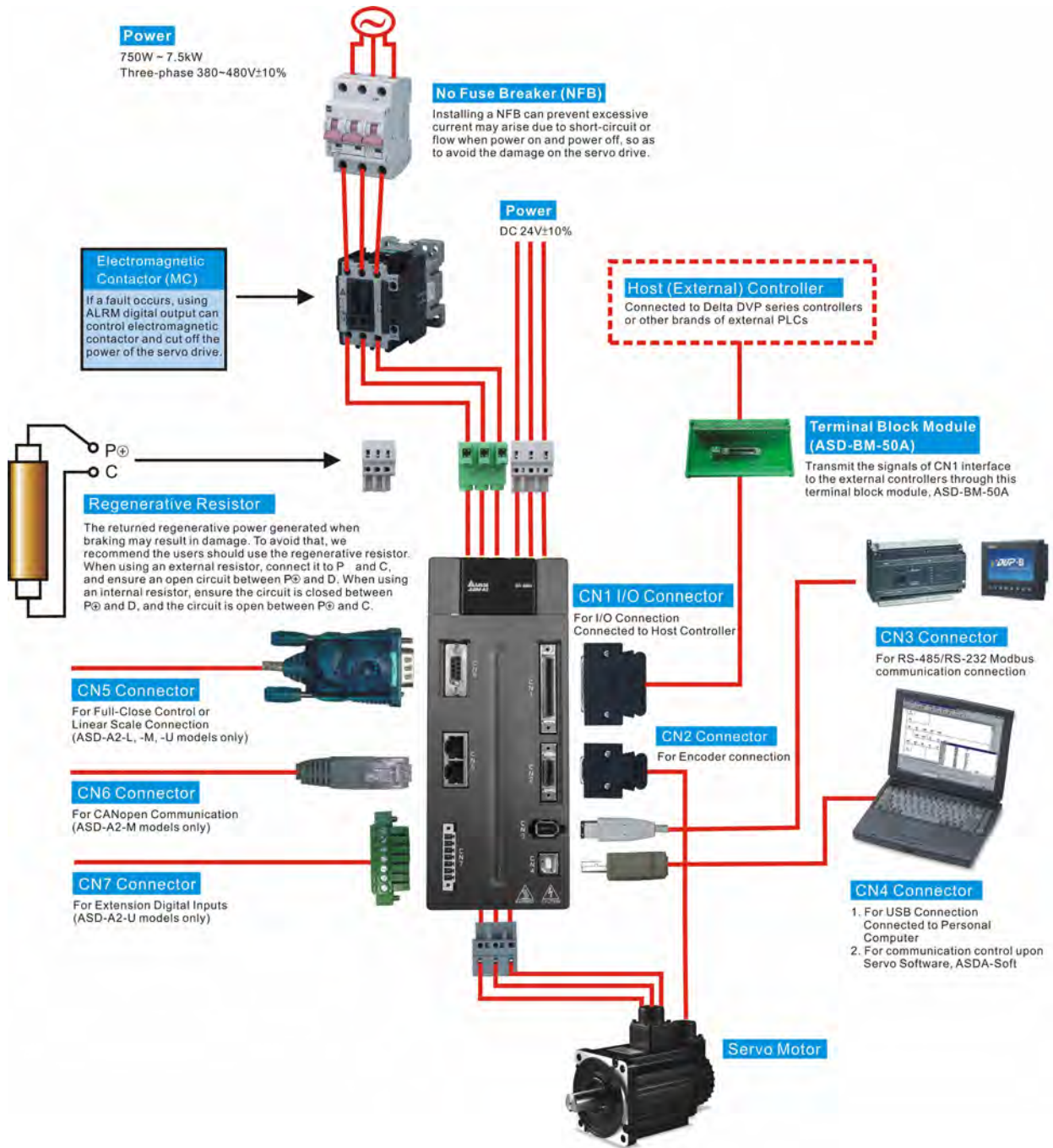
 **NOTE**

- 1) Please use shielded twisted-pair cables for wiring to prevent voltage coupling and eliminate electrical noise and interference.
- 2) The shield of shielded twisted-pair cables should be connected to the SHIELD end (terminal marked ⊕) of the servo drive.
- 3) In order to prevent fire hazard and accidents, please form the wiring by following the cable specifications outlined above.
- 4) The boxes (□) at the ends of the servo drive model names represent the model type of ASDA-A2 series. For the actual model name, please refer to the ordering information of the actual purchased product.
- 5) The boxes (□) in the servo motor model names are for optional configurations (keyway, brake and oil sea).

3.2 Connections - 400V series

3.2.1 Connecting to Peripheral Devices

Figure 3.4 Configuration



3.2.2 Servo Drive Connectors and Terminals

Terminal Identification	Terminal Description	Notes		
DC24V, DC0V	Control circuit terminal	Used to connect single-phase AC control circuit power depending on connecting servo drive model.		
R, S, T	Main circuit terminal	Used to connect three-phase AC main circuit power depending on connecting servo drive model.		
U, V, W FG (⊕)	Servo motor output	Used to connect servo motor		
		Terminal Symbol	Wire Color	Description
		U	Red	Connecting to three-phase motor main circuit cable.
		V	White	
		W	Black	
FG(⊕)	Green	Connecting to ground terminal (⊕) of the servo drive.		
P⊕, D, C, ⊖	Regenerative resistor terminal or braking unit	Internal resistor	Ensure the circuit is closed between P⊕ and D, and the circuit is open between P⊕ and C.	
		External resistor	Connect regenerative resistor to P⊕ and C, and ensure an open circuit between P⊕ and D.	
		External braking unit	Connect braking unit to P⊕ and ⊖, and ensure an open circuit between P⊕ and D, and P⊕ and C. (N terminal is built in L1C, L2C, ⊖, and R, S, T.) P⊕ : Connecting to (+) terminal of V_BUS voltage. ⊖ : Connecting to (-) terminal of V_BUS voltage.	
⊕ two places	Ground terminal	Used to connect grounding wire of power supply and servo motor.		
CN1	I/O connector (Optional Part)	Used to connect external controllers. Please refer to section 3.3 for details.		
CN2	Encoder connector (Optional Part)	Used to connect encoder of servo motor. Please refer to section 3.4 for details.		
		Terminal Symbol	Wire Color	Pin No.
		T+	Blue	5
		T-	Blue/Black	4
		Reserved	-	-
		Reserved	-	-
		+5V	Red & Red/White	14, 16
GND	Black & Black/White	13, 15		

Terminal Identification	Terminal Description	Notes
CN3	Communication connector (Optional Part)	Used for RS-485 or RS-232 communication connection. Please refer to section 3.5 for details.
CN4	USB connector (Type B) (Optional Part)	Used to connect personal computer (PC or notebook). Please refer to section 3.6 for details.
CN5	Position feedback signal connector (for full-closed loop) (Optional Part)	Used to connect to linear scale or encoder to constitute a full-closed loop. Please refer to section 3.7 for details.
CN6	CANopen communication port (Optional Part)	RJ45 connector, used for CANopen communication. Please refer to section 3.8 for details.
CN7	Extension digital input terminal (Optional Part)	Used to connect to extension digital inputs. Please refer to section 3.9 for details.
CN8	Reserved connector	Reserved
CN9	Communication extension connector (Optional Part)	Used to connect to other extension cards (will be available soon).

Wiring Notes

Please observe the following wiring notes while performing wiring and touching any electrical connections on the servo drive or servo motor.

1. Ensure to check if the power supply and wiring of the "power" terminals (R, S, T, DC24V & DC0V) is correct.
2. Please use shielded twisted-pair cables for wiring to prevent voltage coupling and eliminate electrical noise and interference.
3. As a residual hazardous voltage may remain inside the drive, please do not immediately touch any of the "power" terminals (R, S, T, DC24V & DC0V) and/or the cables connected to them after the power has been turned off and the charge LED is lit. (Please refer to the Safety Precautions on page ii).
4. The cables connected to R, S, T and U, V, W terminals should be placed in separate conduits from the encoder or other signal cables. Separate them by at least 30cm (11.8 inches).
5. If the encoder cable (CN2) or the cable for position feedback signal connector (CN5) is too short, please use a twisted-shield signal wire with grounding conductor. The wire length should be 20m (65.62ft.) or less. For lengths greater than 20m

- (65.62ft.), the wire gauge should be doubled in order to lessen any signal attenuation. For the encoder cable specification, please use AWG26 wire size and the Metal braided shield twisted-pair cable which meets the UL2464 specification.
- When using CANopen communication, please use the shielded twisted-pair cables to ensure the communication quality.
 - The shield of shielded twisted-pair cables should be connected to the SHIELD end (terminal marked \ominus) of the servo drive.
 - For the connectors and cables specifications, please refer to section 3.1.6 for details.

3.2.3 Wiring Methods

For 400V series servo drives from 750W to 7.5kW the input power can be three-phase only. Single -phase connections are for 200V series servo drives 1.5kW and below only.

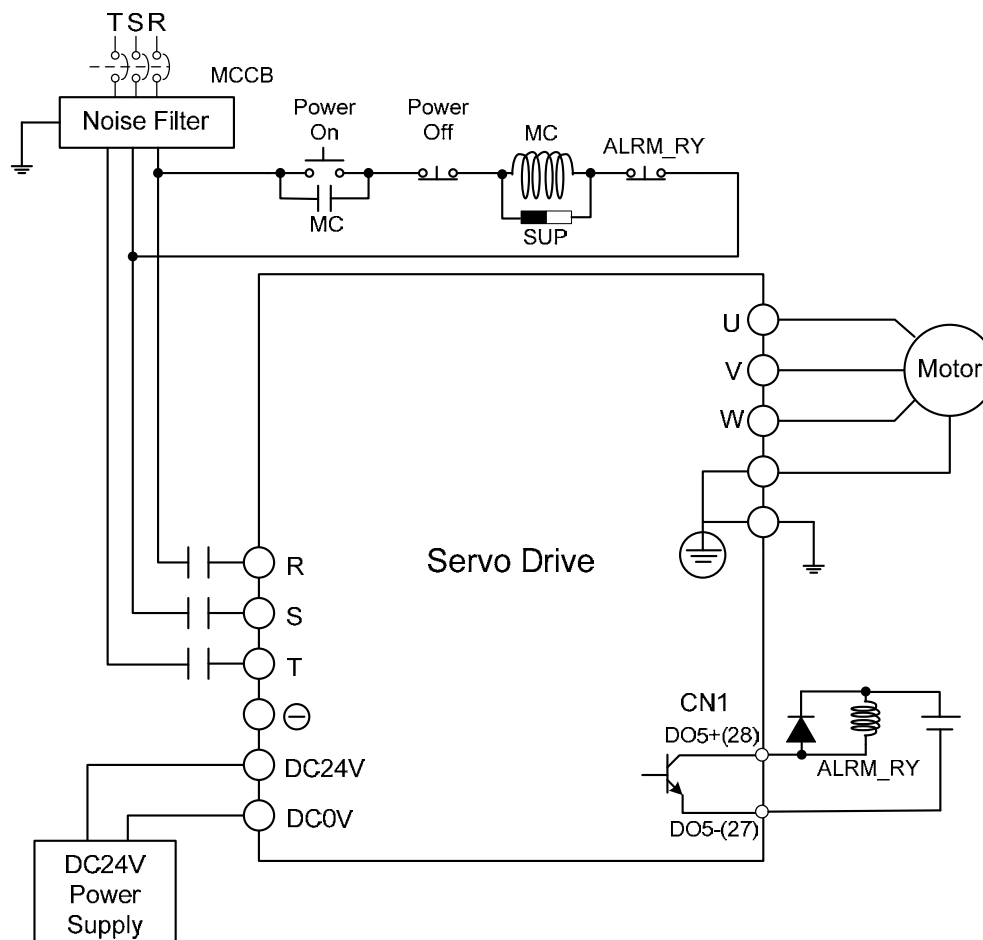
In the wiring diagram figures 3.5:

Power ON : contact "a" (normally open)

Power OFF /ALRM_RY : contact "b" (normally closed)


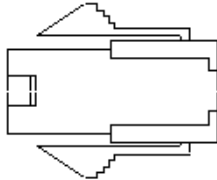
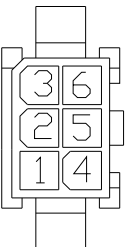
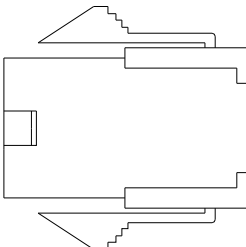
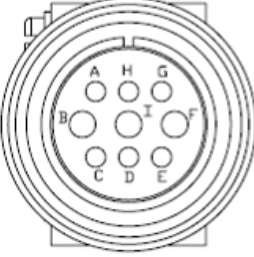

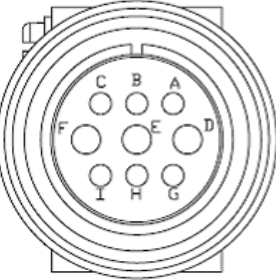

MC : coil of electromagnetic contactor, self-holding power, contact of main circuit power

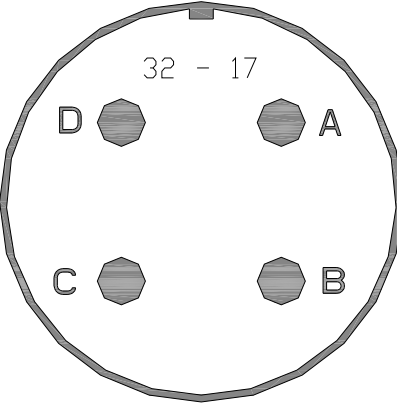
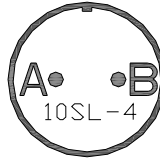
Figure 3.5 Three-Phase Power Supply Connection (for all models)



3.2.4 Motor Power Cable Connector Specifications

The boxes (□) in the model names are for optional configurations. (Please refer to section 1.2 for model explanation.)

Motor Model Name	U, V, W / Electromagnetic Brake Connector	Terminal Identification
ECMA-J10807□S (750W)	  <p>HOUSING: JOWLE (C4201H00-2*2PA)</p>	A
ECMA-J10807□S (750W) *□ : with brake	  <p>HOUSING : JOWLE (C4201H00-2*3PA)</p>	B
ECMA-K11310□S (1000W) ECMA-K11315□S (1500W) ECMA-K11320□S (2000W)	  <p>3106A-20-18S</p>	C
ECMA-L11830□S (3000W) ECMA-L11845□S (4500W) ECMA-L11855□3 (5500W) ECMA-L11875□3 (7500W)	  <p>3106A-24-11S</p>	D

Motor Model Name	U, V, W / Electromagnetic Brake Connector	Terminal Identification
ECMA-F11855□3 (5500W) ECMA-F11875□3 (7500W)		E
ECMA-F21855□3(5500W) ECMA-F21875□3(7500W)		F

Terminal Identification	U (Red)	V (White)	W (Black)	CASE GROUND (Green)	BRAKE1 (Yellow)	BRAKE2 (Blue)
A	1	2	3	4	-	-
B	1	2	4	5	3	6
C	F	I	B	E	G	H
D	D	E	F	G	A	B
E	A	B	C	D	-	-

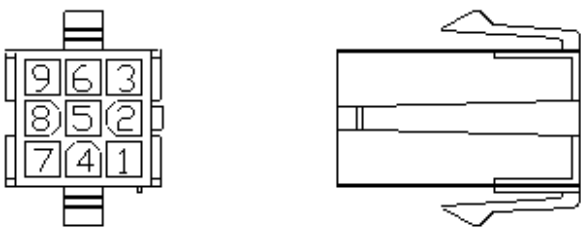
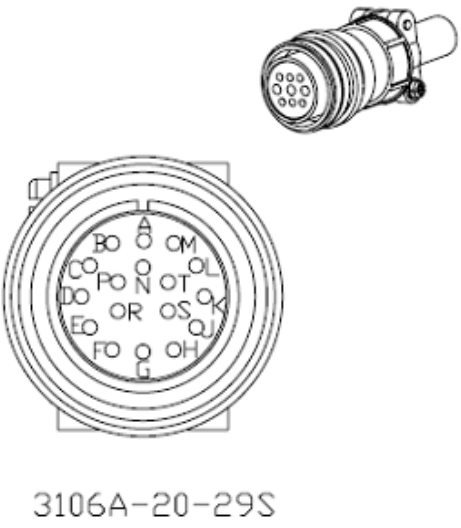
Terminal Identification	BRAKE1	BRAKE2
F	A	B

 **NOTE**

- 1) The coil of brake has no polarity. The names of terminal identification are BRAKE1 (Yellow) and BRAKE2 (Blue).
- 2) The power supply for brake is DC24V. Never use it for VDD, the +24V source voltage.

3.2.5 Encoder Connector Specifications

The boxes (□) in the model names are for optional configurations. (Please refer to section 1.2 for model explanation.)

Motor Model Name	Encoder Connector	Terminal Identification
ECMA-J10807□S (750W)	 <p>HOUSING : AMP (1-172161-9)</p>	A
ECMA-K11310□S (1000W) ECMA-K11315□S (1500W) ECMA-K11320□S (2000W) ECMA-L11830□S (3000W) ECMA-L11845□S (4500W) ECMA-L11855□3 (5500W) ECMA-L11875□3 (7500W)	 <p>3106A-20-29S</p>	B

Terminal Identification	T+	T-	Reserved	Reserved	Reserved	Reserved	DC+5V	GND	BRAID SHELDED
A	1 (Blue)	4 (Blue/Black)	-	-	-	-	7 (Red & Red/White)	8 (Black & Black/White)	9
B	A	B	-	-	-	-	S	R	L

3.2.6 Cable Specifications for Servo Drive

Power Cable

Servo Drive and Servo Motor		Power Cable - Wire Gauge AWG (mm ²)			
		DC24V, DC0V	R, S, T	U, V, W	P [⊕] , C
ASD-A2-0743-□	ECMA-J10807□S	1.3 (AWG16)	2.1 (AWG14)	0.82 (AWG18)	2.1 (AWG14)
ASD-A2-1043-□	ECMA-K11310□S	1.3 (AWG16)	2.1 (AWG14)	1.3 (AWG16)	2.1 (AWG14)
ASD-A2-1543-□	ECMA-K11315□S	1.3 (AWG16)	2.1 (AWG14)	1.3 (AWG16)	2.1 (AWG14)
ASD-A2-2043-□	ECMA-K11320□S	1.3 (AWG16)	2.1 (AWG14)	2.1 (AWG14)	2.1 (AWG14)
ASD-A2-3043-□	ECMA-L11830□S	1.3 (AWG16)	2.1 (AWG14)	3.3 (AWG12)	2.1 (AWG14)
ASD-A2-4543-□	ECMA-L11845□S	1.3 (AWG16)	3.3 (AWG12)	8.4 (AWG8)	3.3 (AWG12)
ASD-A2-5543-□	ECMA-L11855□3	1.3 (AWG16)	3.3 (AWG12)	13.3 (AWG6)	3.3 (AWG12)
ASD-A2-7543-□	ECMA-L11875□3	1.3 (AWG16)	5.3 (AWG10)	13.3 (AWG6)	3.3 (AWG12)

Encoder Cable

Servo Drive	Encoder Cable - Wire Gauge AWG (mm ²)			
	Wire Size	Wire Size	Wire Size	Wire Size
ASD-A2-0743-□	0.13 (AWG26)	10 core (4 pair)	UL2464	3m (9.84ft.)
ASD-A2-1043-□	0.13 (AWG26)	10 core (4 pair)	UL2464	3m (9.84ft.)
ASD-A2-1543-□	0.13 (AWG26)	10 core (4 pair)	UL2464	3m (9.84ft.)
ASD-A2-2043-□	0.13 (AWG26)	10 core (4 pair)	UL2464	3m (9.84ft.)
ASD-A2-3043-□	0.13 (AWG26)	10 core (4 pair)	UL2464	3m (9.84ft.)
ASD-A2-4543-□	0.13 (AWG26)	10 core (4 pair)	UL2464	3m (9.84ft.)
ASD-A2-5543-□	0.13 (AWG26)	10 core (4 pair)	UL2464	3m (9.84ft.)
ASD-A2-7543-□	0.13 (AWG26)	10 core (4 pair)	UL2464	3m (9.84ft.)

NOTE

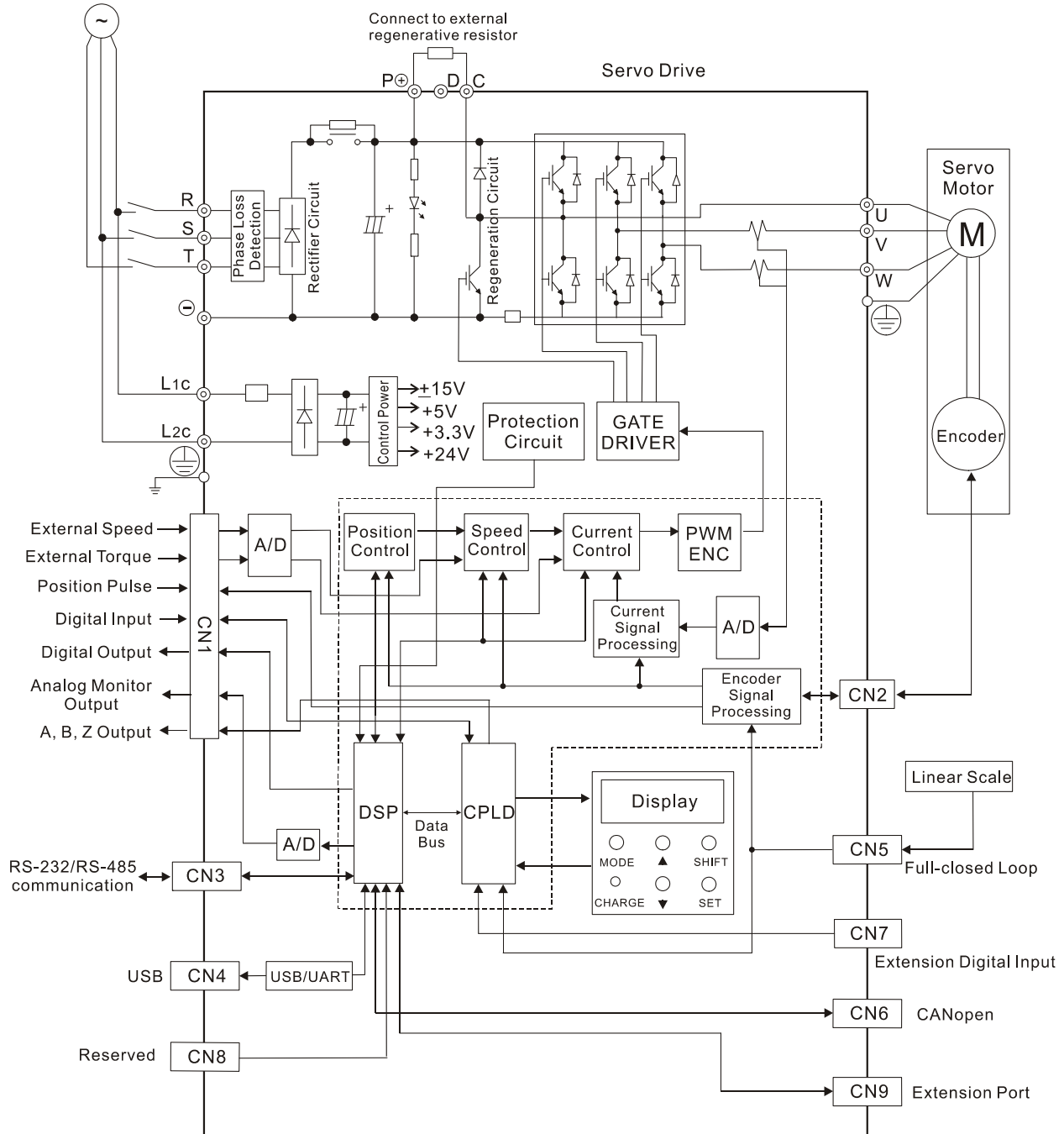
- 1) Please use shielded twisted-pair cables for wiring to prevent voltage coupling and eliminate electrical noise and interference.
- 2) The shield of shielded twisted-pair cables should be connected to the SHIELD end (terminal marked ⊕) of the servo drive.
- 3) In order to prevent fire hazard and accidents, please form the wiring by following the cable specifications outlined above.
- 4) The boxes (□) at the ends of the servo drive model names represent the model type of ASDA-A2 series. For the actual model name, please refer to the ordering information of the actual purchased product.
- 5) The boxes (□) in the servo motor model names are for optional configurations (keyway, brake and oil sea).

3.3 Basic Wiring

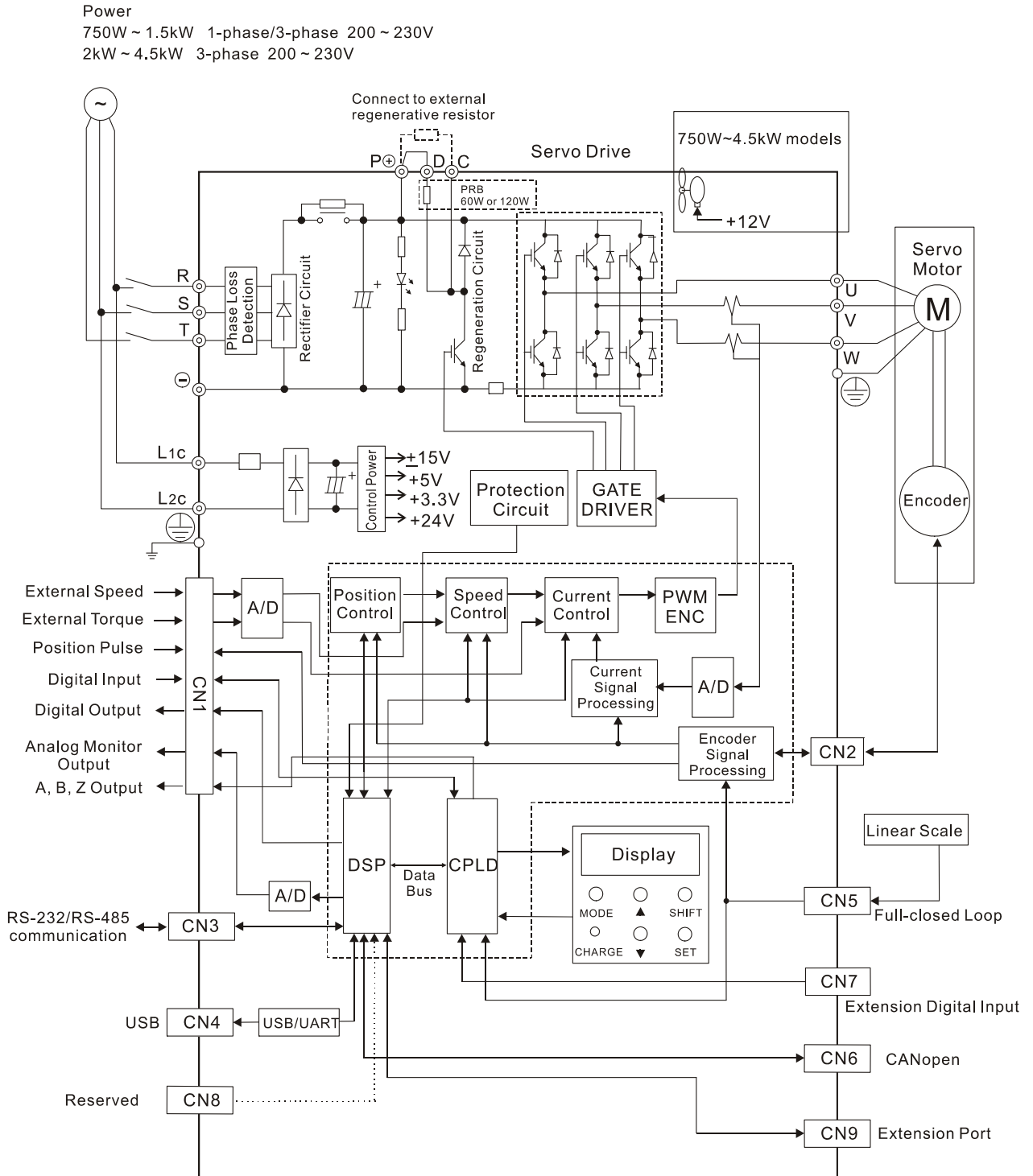
3.3.1 220V series

**Figure 3.6 Basic Wiring Schematic of 400W and below models
(Without built-in regenerative resistor)**

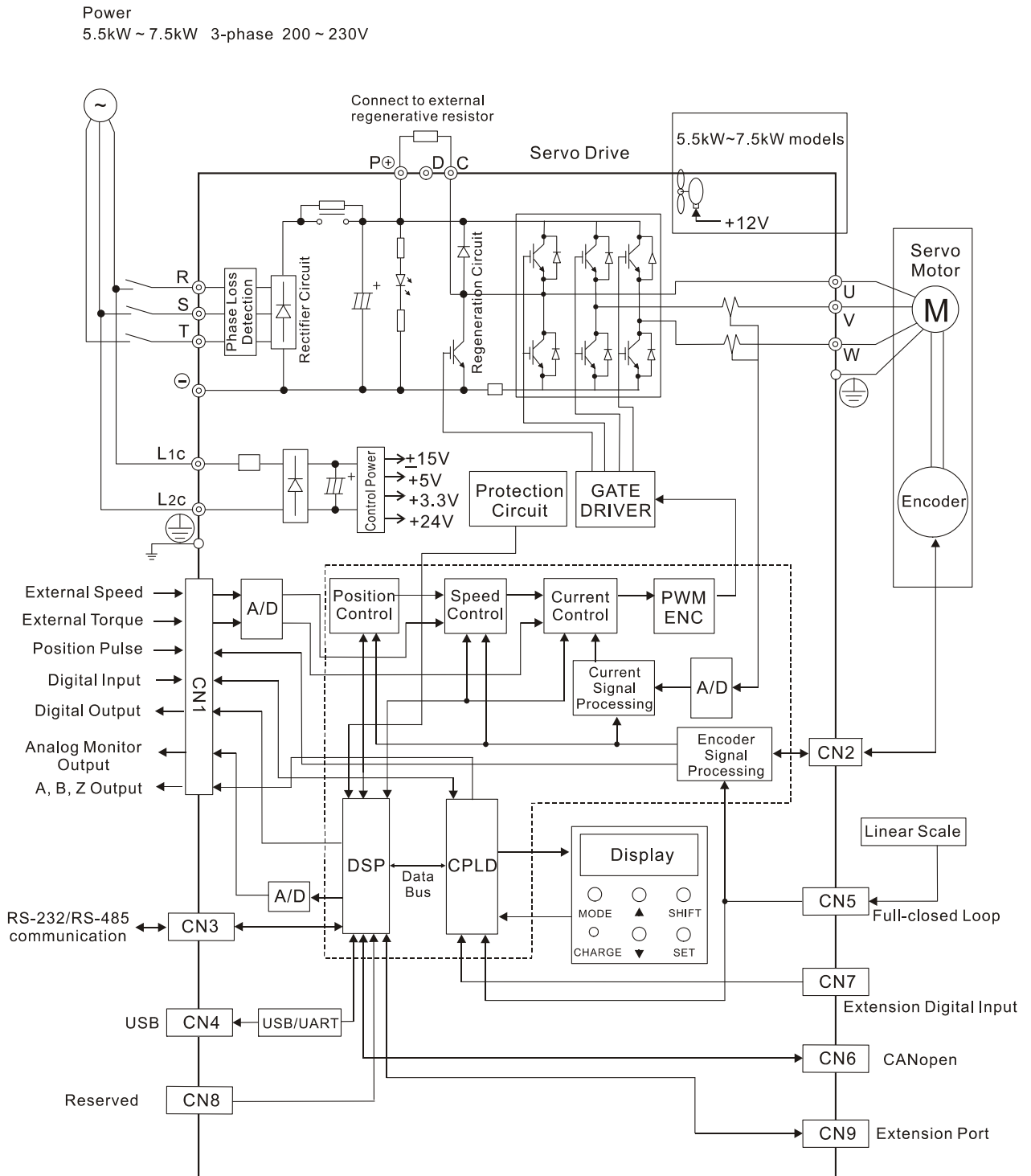
Power
100W ~ 400W 1-phase/3-phase 200 ~ 230V



**Figure 3.7 Basic Wiring Schematic of 750W to 4.5kW models
(With built-in regenerative resistor and fan)**

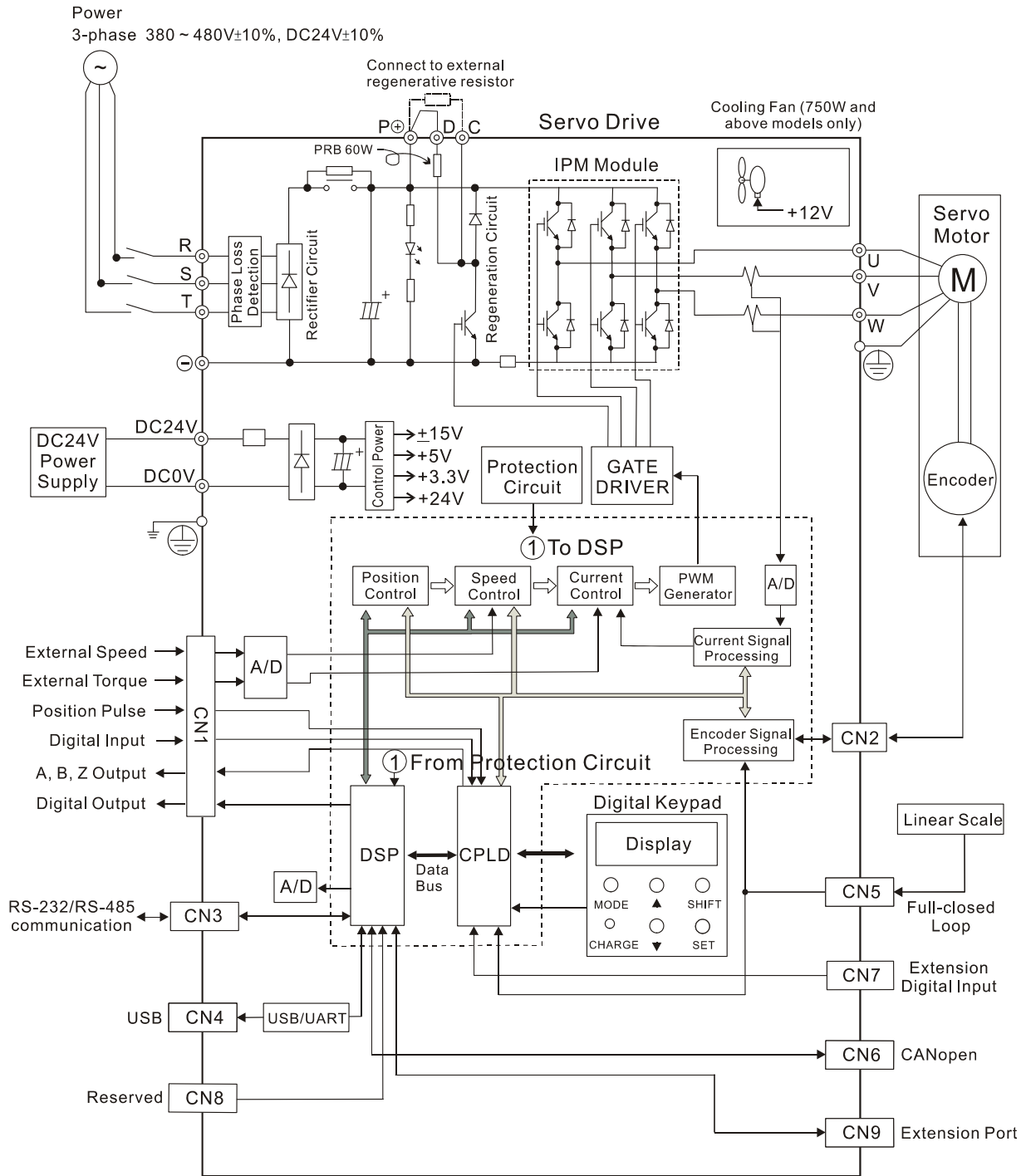


**Figure 3.8 Basic Wiring Schematic of 5.5kW to 7.5kW models
(With built-in fan but no regenerative resistor)**

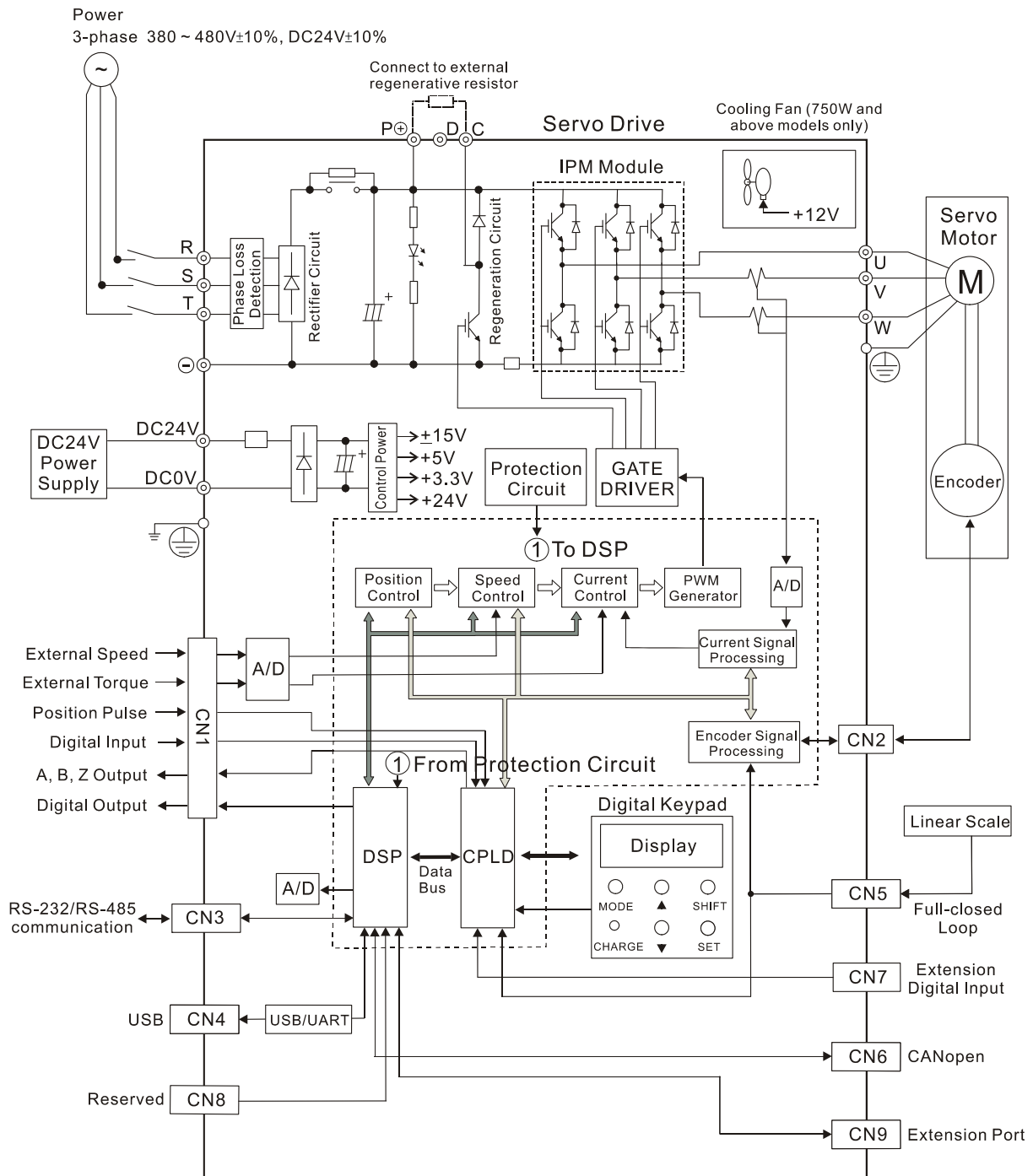


3.3.2 400V series

Figure 3.9 Basic Wiring Schematic of 750W to 1.5kW models
(With built-in regenerative resistor and fan)



**Figure 3.10 Basic Wiring Schematic of 2kW to 5.5kW models
(With built-in fan but no regenerative resistor)**



3.4 Input / Output Interface Connector -CN1

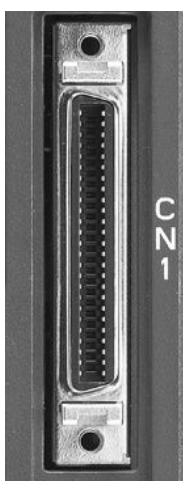
The CN1 Interface Connector provides access to three signal groups:

- i General interface for the analog speed and torque control, encoder reference signal from the motor, pulse / direction inputs, and reference voltages.
- ii 8 programmable Digital Inputs (DI), can be set via parameters P2-10 ~ P2-17
- iii 5 programmable Digital Outputs (DO), can be set via parameters P2-18 ~ P2-22

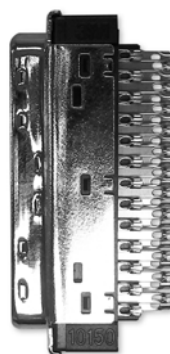
A detailed explanation of each group is available in Section 3.3.2, Tables 3.A, 3.B & 3.C.

3.4.1 CN1 Terminal Identification

Figure 3.11 The Layout of CN1 Drive Connector



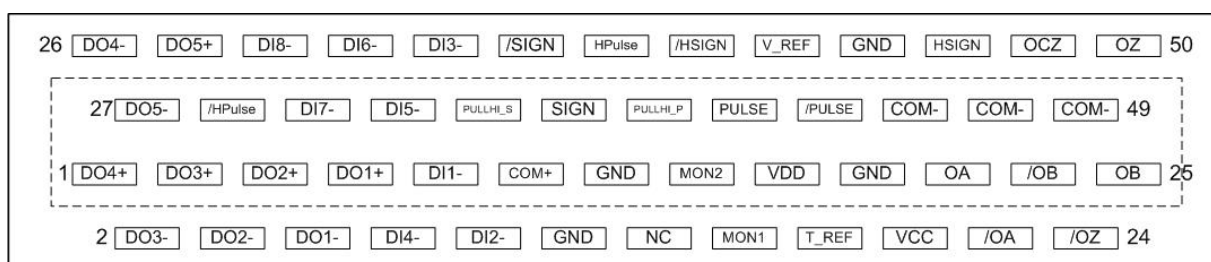
CN1 Drive Connector



Side View



Rear View



CN1 Terminal Signal Identification

2	DO3-	Digital output	1	DO4+	Digital output	26	DO4-	Digital output
4	DO2-	Digital output	3	DO3+	Digital output	27	DO5-	Digital output
6	DO1-	Digital output	5	DO2+	Digital output	28	DO5+	Digital output
8	DI4-	Digital input	7	DO1+	Digital output	29	/HPULSE	High-speed position pulse (-)
10	DI2-	Digital input	9	DI1-	Digital input	30	DI8-	Digital input
12	GND	Analog input signal ground	11	COM+	Power input (12~24V)	31	DI7-	Digital input
14	NC	No Connection	13	GND	Analog input signal ground	33	DI5-	Digital input
16	MON1	Analog monitor output 1	15	MON2	Analog monitor output 2	35	PULL HI_S (SIGN)	Pulse applied power (SIGN)
18	T_REF	Analog torque Input	17	VDD	+24V power output (for external I/O)	37	SIGN	Position sign (+)
20	VCC	+12V power output (for analog command)	19	GND	Analog input signal ground	39	PULL HI_P (PULSE)	Pulse applied Power (PULSE)
22	/OA	Encoder /A pulse output	21	OA	Encoder A pulse output	41	PULSE	Pulse input (+)
24	/OZ	Encoder /Z pulse output	23	/OB	Encoder /B pulse output	43	/PULSE	Pulse input (-)
			25	OB	Encoder B pulse output	45	COM-	VDD(24V) power ground
						47	COM-	VDD(24V) power ground
						49	COM-	VDD(24V) power ground
						50	OZ	Encoder Z pulse line-driver output

NOTE

- 1) The terminal marked "NC" must be left unconnected (No Connection). The NC terminal is used within the servo drive. Any outside connection to the NC terminal will result in damage to the drive and void the warranty!

3.4.2 Signals Explanation of Connector CN1

The Tables 3.A, 3.B, & 3.C detail the three groups of signals of the CN1 interface. Table 3.A details the general signals. Table 3.B details the Digital Output (DO) signals and Table 3.C details the Digital Input (DI) signals. The General Signals are set by the factory and can not be changed, reprogrammed or adjusted. Both the Digital Input and Digital Output signals can be programmed by the users.

Table 3.A General Signals

Signal		Pin No	Details	Wiring Diagram (Refer to 3.3.4)
Analog Signal Input	V_REF	42	1. Motor speed command: -10V to +10V, corresponds to -3000 ~ +3000 r/min speed command (Factory default setting). 2. Motor speed command: -10V to +10V, corresponds to -3 ~ +3 rotations position command (Factory default setting).	C1
	T_REF	18	Motor torque command: -10V to +10V, corresponds to -100% to +100% rated torque command.	C1
Analog Monitor Output	MON1 MON2	16 15	Monitor operation status: Motor characteristics such as speed and current can be represented by analog voltages. The drive provides two channels which can be configured with the parameter P0-03 to output the desired characteristics. Please reference the parameter P0-03 for monitoring commands and P1-04 / P1-05 for scaling factors. Output voltage is reference to the power ground.	C2
Position Pulse Input	PULSE /PULSE SIGN /SIGN	43 41 36 37	The drive can accept two different types of pulse inputs: Line-driver input (max. input frequency is 500Kpps) and Open-collector input (max. input frequency is 200Kpps). Three different pulse commands can be selected via parameter P1-00. They are A phase + B phase (Quadrature), CW pulse + CCW pulse, and Pulse + Direction.	C3/C4
	PULL HI_P PULL HI_S	39 35	When an Open-collector type of pulse is used, this terminal must be connected to a pull-up power supply.	C3/C4
High- speed Position Pulse Input	HSIGN /HSIGN HPULSE /HPULSE	46 40 38 29	The drive can accept two different types of high-speed pulse inputs: +5V input and Line-driver input. The max. input frequency is 4MHz. Three different pulse commands can be selected via parameter P1-00. They are A phase + B phase (Quadrature), CW pulse + CCW pulse, and Pulse + Direction.	C4-2

Signal		Pin No	Details	Wiring Diagram (Refer to 3.3.4)
Position Pulse Output	OA	21	Encoder signal output A, B, Z (Line-driver output). The motor encoder signals are available through these terminals.	C13/C14
	/OA	22		
	OB	25		
	/OB	23		
	OZ	50	Encoder signal output Z (Open-collector output).	-
	/OZ	24		
Power	OCZ	48		
	VDD	17	VDD is the +24V source voltage provided by the drive. Maximum permissible current 500mA.	-
	COM+	11	COM+ is the common voltage rail of the Digital Input (DI) and Digital Output (DO) signals. When using VDD, VDD should be connected to COM+. If not using VDD, the users should add an external applied power (+12V to +24V). The positive end of this applied power should be connected to COM+ and the negative end of this applied power should be connected to COM-.	
	COM-	45		
	47			
		49		
	VCC	20	VCC is a +12V power rail provided by the drive. It is used for providing simple analog command (analog speed or analog torque command). Maximum permissible current 100mA.	
	GND	12,13, 19,44	The polarity of VCC is with respect to Ground (GND).	
Other	NC	14	See previous note for NC terminal description of CN1 connector on page 3-13.	

The Digital Input (DI) and Digital Output (DO) have factory default settings which correspond to the various servo drive control modes. (See section 6.1). However, both the DI's and DO's can be programmed independently to meet the requirements of the users. Detailed in Tables 3.B and 3.C are the DO and DI functions with their corresponding signal name and wiring schematic. The factory default settings of the DI and DO signals are detailed in Table 3.G and 3.H.

All of the DI's and DO's and their corresponding pin numbers are factory set and non-changeable, however, all of the assigned signals and control modes are user changeable. For Example, the factory default setting of DO5 (pins 28/27) can be assigned to DO1 (pins 7/6) and vice versa.

The following Tables 3.B and 3.C detail the functions, applicable operational modes, signal name and relevant wiring schematic of the default DI and DO signals.

Table 3.B DO Signals

DO Signal	Assigned Control Mode	Pin No. (Default)		Details	Wiring Diagram (Refer to 3.3.4)
		+	-		
SRDY	ALL	7	6	SRDY is activated when the servo drive is ready to run. All fault and alarm conditions, if present, have been cleared.	C5/C6/C7/C8
SON	Not assigned	-	-	SON is activated when control power is applied the servo drive. The drive may or may not be ready to run as a fault / alarm condition may exist. Servo ON (SON) is "ON" with control power applied to the servo drive, there may be a fault condition or not. The servo is not ready to run. Servo ready (SRDY) is "ON" where the servo is ready to run, NO fault / alarm exists.	
ZSPD	ALL	5	4	ZSPD is activated when the drive senses the motor is equal to or below the Zero Speed Range setting as defined in parameter P1-38. For Example, at factory default ZSPD will be activated when the drive detects the motor rotating at speed at or below 10 r/min, ZSPD will remain activated until the motor speed increases above 10 r/min.	
TSPD	ALL (except PT, PR)	-	-	TSPD is activated once the drive has detected the motor has reached the Target Rotation Speed setting as defined in parameter P1-39. TSPD will remain activated until the motor speed drops below the Target Rotation Speed.	
TPOS	PT, PR, PT-S, PT-T, PR-S, PR-T	1	26	<ol style="list-style-type: none"> When the drive is in PT mode, TPOS will be activated when the position error is equal and below the setting value of P1-54. When the drive is in PR mode, TPOS will be activated when the drive detects that the position of the motor is in a -P1-54 to +P1-54 band of the target position. For Example, at factory default TPOS will activate once the motor is in -99 pulses range of the target position, then deactivate after it reaches +99 pulses range of the desired position. 	
TQL	Not assigned	-	-	TQL is activated when the drive has detected that the motor has reached the torques limits set by either the parameters P1-12 ~ P1-14 of via an external analog voltage.	
ALRM	ALL	28	27	ALRM is activated when the drive has detected a fault condition. (However, when Reverse limit error, Forward limit error, Emergency stop, Serial communication error, and Undervoltage these fault occur, WARN is activated first.)	

DO Signal	Assigned Control Mode	Pin No. (Default)		Details	Wiring Diagram (Refer to 3.3.4)
		+	-		
BRKR	ALL	-	-	BRKR is activated actuation of motor brake.	C5/C6/C7/C8
HOME	ALL	3	2	HOME is activated when the servo drive has detected that the "HOME" sensor (ORGP, digital input 0x24) has been detected.	
OLW	ALL	-	-	OLW is activated when the servo drive has detected that the motor has reached the output overload level set by the parameter P1-56.	
WARN	ALL	-	-	Servo warning output. WARN is activated when the drive has detected Reverse limit error, Forward limit error, Emergency stop, Serial communication error, and Undervoltage these fault conditions.	
OVF	ALL	-	-	Position command overflow. OVF is activated when the servo drive has detected that a position command overflows.	
SNL (SCWL)	PR	-	-	Reverse software limit. SNL is activated when the servo drive has detected that reverse software limit is reached.	
SPL (SCCWL)	PR	-	-	Forward software limit. SPL is activated when the servo drive has detected that forward software limit is reached.	
CMD_OK	PR	-	-	Internal position command completed output. CMDOK is activated when the servo drive has detected that the internal position command has been completed.	
CAP_OK	PR	-	-	Capture operation completed output. CAP_OK is activated when the servo drive has detected that capture operation has been completed.	
MC_OK	PR	-	-	Motion control completed output. MC_OK is activated when CMD_OK and TPOS are both ON. It indicates MC_OK is activated only when the servo drive has detected that the position command has been given and the positioning has been completed also. If only CMD_OK or TPOS is ON, MC_OK will not be activated.	
CAM_AREA	PR	-	-	CAM_AREA is activated when the servo drive has detected the master position of E-CAM (electronic CAM) is within the setting area.	
SP_OK	S, Sz	-	-	SP_OK will be activated when the speed error is equal and below the setting value of P1-47.	
SDO_0	ALL	-	-	Output the status of bit00 of P4-06.	
SDO_1	ALL	-	-	Output the status of bit01 of P4-06.	
SDO_2	ALL	-	-	Output the status of bit02 of P4-06.	
SDO_3	ALL	-	-	Output the status of bit03 of P4-06.	

DO Signal	Assigned Control Mode	Pin No. (Default)		Details	Wiring Diagram (Refer to 3.3.4)
		+	-		
SDO_4	ALL	-	-	Output the status of bit04 of P4-06.	C5/C6/C7/C8
SDO_5	ALL	-	-	Output the status of bit05 of P4-06.	
SDO_6	ALL	-	-	Output the status of bit06 of P4-06.	
SDO_7	ALL	-	-	Output the status of bit07 of P4-06.	
SDO_8	ALL	-	-	Output the status of bit08 of P4-06.	
SDO_9	ALL	-	-	Output the status of bit09 of P4-06.	
SDO_A	ALL	-	-	Output the status of bit10 of P4-06.	
SDO_B	ALL	-	-	Output the status of bit11 of P4-06.	
SDO_C	ALL	-	-	Output the status of bit12 of P4-06.	
SDO_D	ALL	-	-	Output the status of bit13 of P4-06.	
SDO_E	ALL	-	-	Output the status of bit14 of P4-06.	
SDO_F	ALL	-	-	Output the status of bit15 of P4-06.	

 **NOTE**

- 1) PINS 3 & 2 can either be TSPD or HOME dependent upon control mode selected.
- 2) The DO signals that do not have pin numbers in Tables 3.B are not default DO signals. If the users want to use these non-default DO signals, the users need to change the settings of parameters P2-18 ~ P2-22. The “state” of the output function may be turned ON or OFF as it will be dependant on the settings of parameters P2-18 ~ P2-22. Please refer to section 3.3.3 for details.

Table 3.C DI Signals

DI Signal	Assigned Control Mode	Pin No. (Default)	Details	Wiring Diagram (Refer to 3.3.4)
SON	ALL	9	Servo On. Switch servo to "Servo Ready".	C9/C10/C11 /C12
ARST	ALL	33	A number of Faults (Alarms) can be cleared by activating ARST. Please see table 10-3 for applicable faults that can be cleared with the ARST command. However, please investigate Fault or Alarm if it does not clear or the fault description warrants closer inspection of the drive system.	
GAINUP	ALL	-	Gain switching	
CCLR	PT, PR	10	When CCLR is activated, the setting parameter P2-50 Pulse Clear Mode is executed.	
ZCLAMP	ALL	-	When this signal is On and the motor speed value is lower than the setting value of P1-38, it is used to lock the motor in the instant position while ZCLAMP is On.	
CMDINV	PR, T, S	-	When this signal is On, the motor is in reverse rotation.	
CTRG	PR, PR-S, PR-T, S, Sz	10	When the drive is in PR mode and CTRG is activated, the drive will command the motor to move the stored position which correspond the POS 0 ~ POS 5 settings. Activation is triggered on the rising edge of the pulse.	
TRQLM	S, Sz	10	ON indicates the torque limit command is valid.	
SPDLM	T, Tz	10	ON indicates the speed limit command is valid.	
POS0	PR, PR-S, PR-T	34	When the PR Control Mode is selected, the 64 stored positions are programmed via a combination of the POS 0 ~ POS 5 commands. See table 3.D.	
POS1		8		
POS2		-		
POS3		-		
POS4		-		
POS5		-		
STOP	-	-	Motor stop.	
SPD0	S, Sz, PT-S, PR-S, S-T	34	Select the source of speed command:	
SPD1		8	See table 3.E.	

DI Signal	Assigned Control Mode	Pin No. (Default)	Details	Wiring Diagram (Refer to 3.3.4)
TCM0	PT, T, Tz,	34	Select the source of torque command: See table 3.F.	C9/C10/C11 /C12
TCM1	PT-T, PR-T, S-T	8		
S-P	PT-S, PR-S	31	Speed / Position mode switching OFF: Speed, ON: Position	
S-T	S-T	31	Speed / Torque mode switching OFF: Speed, ON: Torque	
T-P	PT-T, PR-T	31	Torque / Position mode switching OFF: Torque, ON: Position	
PT-PR	PT, PR	-	Internal position (PR) and external pulse (PT) mode switching. OFF: PT, ON: PR	
PTAS	PT	-	External command source selection: pulse and analog voltage switching. OFF: The command source is external pulse. ON: The command source is external analog voltage.	
PTCMS	PT	-	External command source selection: high-speed / low-speed pulse switching OFF: The command source is low-speed pulse (PULSE, /PULSE, SIGN, /SIGN). ON: The command source is high-speed pulse (HPULSE, /HPULSE, HSIGN, /HSIGN). When high-speed pulse is selected, the users can add an external manual pulse generator and use this DI signal to switch the command source.	
EMGS	ALL	30	It should be contact "b" and normally ON or a fault (AL013) will display.	
NL(CWL)	PT, PR, S, T, Sz, Tz	32	Reverse inhibit limit. It should be contact "b" and normally ON or a fault (AL014) will display.	
PL(CCWL)	PT, PR, S, T, Sz, Tz	31	Forward inhibit limit. It should be contact "b" and normally ON or a fault (AL015) will display.	
ORGP	PR	-	When ORGP is activated, the drive will command the motor to start to search the reference "Home" sensor.	
SHOM	PR	-	When SHOM is activated, the drive will command the motor to move to "Home".	
CAM	PR	-	Electronic cam engaging control. [see P5-88]	
JOGU	ALL	-	Forward JOG input. When JOGU is activated, the motor will JOG in forward direction. [see P4-05]	

DI Signal	Assigned Control Mode	Pin No. (Default)	Details	Wiring Diagram (Refer to 3.3.4)
JOGD	ALL	-	Reverse JOG input. When JOGD is activated, the motor will JOG in reverse direction. [see P4-05]	C9/C10/C11 /C12
EV1	PR	-	Event trigger command 1.	
EV2	PR	-	Event trigger command 2.	
EV3	PR	-	Event trigger command 3. (available for ASDA-A2 firmware version V1.008 sub04 or later)	
EV4	PR	-	Event trigger command 4. (available for ASDA-A2 firmware version V1.008 sub04 or later)	
GNUM0	PT, PR, PT-S, PR-S	-	Electronic gear ratio (Numerator) selection 0. [See P2-60~P2-62]	
GNUM1	PT, PR, PT-S, PR-S	-	Electronic gear ratio (Numerator) selection 1. [See P2-60~P2-62]	
INHP	PT, PT-S	-	Pulse inhibit input. When the drive is in position mode, if INHP is activated, the external pulse input command is not valid.	

 **NOTE**

- 1) The DI signals that do not have pin numbers in Tables 3.C are not default DI signals. If the users want to use these non-default DI signals, the users need to change the settings of parameters P2-10 ~ P2-17. The “state” of the output function may be turned ON or OFF as it will be dependant on the settings of parameters P2-10 ~ P2-17. Please refer to section 3.3.3 for details.

Table 3.D Source of Position Command

Position Command	POS5	POS4	POS3	POS2	POS1	POS0	CTRG	Parameters
P1	ON	ON	ON	ON	ON	ON	↑	P6-00
								P6-01
P2	ON	ON	ON	ON	ON	OFF	↑	P6-02
								P6-03
~								~
P50	OFF	OFF	ON	ON	OFF	ON	↑	P6-98
								P6-99
P51	OFF	OFF	ON	ON	OFF	OFF	↑	P7-00
								P7-01
~								~
P64	OFF	OFF	OFF	OFF	OFF	OFF	↑	P7-26
								P7-27

Table 3.E Source of Speed Command

SPD1	SPD0	Parameters
OFF	OFF	S mode: analog input Sz mode: 0
OFF	ON	P1-09
ON	OFF	P1-10
ON	ON	P1-11

Table 3.F Source of Torque Command

TCM1	TCM0	Parameters
OFF	OFF	T mode: analog input Tz mode: 0
OFF	ON	P1-12
ON	OFF	P1-13
ON	ON	P1-14

The default DI and DO signals in different control mode are listed in the following table 3.G and table 3.H. Although the content of the table 3.G and table 3.H do not provide more information than the table 3.B and table 3.C above, as each control mode is separated and listed in different row, it is easy for user to view and can avoid confusion. However, the Pin number of each signal can not be displayed in the table 3.G and table 3.H.

Table 3.G Default DI signals and Control modes

Signal	DI Code	Function	PT	PR	S	T	Sz	Tz	PT-S	PT-T	PR-S	PR-T	S-T
SON	0x01	Servo On	DI1	DI1	DI1	DI1	DI1	DI1	DI1	DI1	DI1	DI1	DI1
ARST	0x02	Reset	DI5	DI5	DI5	DI5	DI5	DI5					
GAINUP	0x03	Gain switching											
CCLR	0x04	Pulse clear	DI2						DI2	DI2			
ZCLAMP	0x05	Low speed CLAMP											
CMDINV	0x06	Command input reverse control											
Reserved	0x07	Reserved											
CTRG	0x08	Command triggered		DI2							DI2	DI2	
TRQLM	0x09	Torque limit enabled			DI2		DI2						
SPDLM	0x10	Speed limit enabled				DI2		DI2					
POS0	0x11	Position command selection 0 (1~64)		DI3							DI3	DI3	
POS1	0x12	Position command selection 1 (1~64)		DI4							DI4	DI4	
POS2	0x13	Position command selection 2 (1~64)											
POS3	0x1A	Position command selection 3 (1~64)											
POS4	0x1B	Position command selection 4 (1~64)											
POS5	0x1C	Position command selection 5 (1~64)											
STOP	0x46	Motor stop											
SPD0	0x14	Speed command selection 0 (1~4)			DI3		DI3		DI3		DI5		DI3
SPD1	0x15	Speed command selection 1 (1~4)			DI4		DI4		DI4		DI6		DI4
TCM0	0x16	Torque command selection 0 (1~4)	DI3			DI3		DI3		DI3		DI5	DI5
TCM1	0x17	Torque command selection 1 (1~4)	DI4			DI4		DI4		DI4		DI6	DI6
S-P	0x18	Position / Speed mode switching (OFF: Speed, ON: Position)							DI7		DI7		
S-T	0x19	Speed / Torque mode switching (OFF: Speed, ON: Torque)											DI7
T-P	0x20	Torque / Position mode switching (OFF: Torque, ON: Position)								DI7		DI7	

Chapter 3 Connections and Wiring

ASDA-A2

Signal	DI Code	Function	PT	PR	S	T	Sz	Tz	PT-S	PT-T	PR-S	PR-T	S-T
PT-PR	0x2B	Internal position (PR) and external pulse (PT) mode switching (OFF: PT, ON: PR)											
PTAS	0x2C	External command source selection: pulse and analog voltage switching (in PT mode only)											
PTCMS	0x2D	External command source selection: high-speed / low-speed pulse switching (in PT mode only)											
EMGS	0x21	Emergency stop	DI8	DI8	DI8	DI8	DI8	DI8	DI8	DI8	DI8	DI8	DI8
NL(CWL)	0x22	Reverse inhibit limit	DI6	DI6	DI6	DI6	DI6	DI6					
PL(CCWL)	0x23	Forward inhibit limit	DI7	DI7	DI7	DI7	DI7	DI7					
ORGP	0x24	Reference "Home" sensor											
SHOM	0x27	Move to "Home"											
CAM	0x36	Electronic cam engaging control											
JOGU	0x37	Forward JOG input											
JOGD	0x38	Reverse JOG input											
EV1	0x39	Event trigger command 1 [see P5-98, P5-99]											
EV2	0x3A	Event trigger command 2 [see P5-98, P5-99]											
EV3	0x3B	Event trigger command 1 (available for ASDA-A2 firmware version V1.008 sub04 or later)											
EV4	0x3C	Event trigger command 2 (available for ASDA-A2 firmware version V1.008 sub04 or later)											
GNUM0	0x43	Electronic gear ratio (Numerator) selection 0											
GNUM1	0x44	Electronic gear ratio (Numerator) selection 1											
INHP	0x45	Pulse inhibit input											



- 1) For Pin numbers of DI1~DI8 signals, please refer to section 3.3.1.

Table 3.H Default DO signals and Control modes

Signal	DO Code	Function	PT	PR	S	T	Sz	Tz	PT-S	PT-T	PR-S	PR-T	S-T
SRDY	0x01	Servo ready	DO1	DO1	DO1	DO1	DO1	DO1	DO1	DO1	DO1	DO1	DO1
SON	0x02	Servo On											
ZSPD	0x03	At Zero speed	DO2	DO2	DO2	DO2	DO2	DO2	DO2	DO2	DO2	DO2	DO2
TSPD	0x04	At Speed reached			DO3	DO3	DO3	DO3	DO3	DO3	DO3	DO3	DO3
TPOS	0x05	At Positioning completed	DO4	DO4					DO4	DO4	DO4	DO4	DO4
TQL	0x06	At Torques limit											
ALRM	0x07	Servo alarm (Servo fault) activated	DO5	DO5	DO5	DO5	DO5	DO5	DO5	DO5	DO5	DO5	DO5
BRKR	0x08	Electromagnetic brake control			DO4	DO4	DO4	DO4					
HOME	0x09	Homing completed	DO3	DO3									
OLW	0x10	Output overload warning											
WARN	0x11	Servo warning activated											
OVF	0x12	Position command overflow											
SNL (SCWL)	0x13	Reverse software limit											
SPL (SCCWL)	0x14	Forward software limit											
CMD_OK	0x15	Internal position command completed output											
CAP_OK	0x16	Capture operation completed output											
MC_OK	0x17	Motion control completed output											
CAM_AREA	0x18	Master position of E-CAM (electronic CAM)											
SP_OK	0x19	Speed reached output											
SDO_0	0x30	Output the status of bit00 of P4-06.											

Signal	DO Code	Function	PT	PR	S	T	Sz	Tz	PT-S	PT-T	PR-S	PR-T	S-T
SDO_1	0x31	Output the status of bit01 of P4-06.											
SDO_2	0x32	Output the status of bit02 of P4-06.											
SDO_3	0x33	Output the status of bit03 of P4-06.											
SDO_4	0x34	Output the status of bit04 of P4-06.											
SDO_5	0x35	Output the status of bit05 of P4-06.											
SDO_6	0x36	Output the status of bit06 of P4-06.											
SDO_7	0x37	Output the status of bit07 of P4-06.											
SDO_8	0x38	Output the status of bit08 of P4-06.											
SDO_9	0x39	Output the status of bit09 of P4-06.											
SDO_A	0x3A	Output the status of bit10 of P4-06.											
SDO_B	0x3B	Output the status of bit11 of P4-06.											
SDO_C	0x3C	Output the status of bit12 of P4-06.											
SDO_D	0x3D	Output the status of bit13 of P4-06.											
SDO_E	0x3E	Output the status of bit14 of P4-06.											
SDO_F	0x3F	Output the status of bit15 of P4-06.											

 **NOTE**

- 1) For Pin numbers of DO1~DO5 signals, please refer to section 3.3.1.

3.4.3 User-defined DI and DO signals

If the default DI and DO signals could not be able to fulfill users' requirements, there are still user-defined DI and DO signals. The setting method is easy and they are all defined via parameters. The user-defined DI and DO signals are defined via parameters P2-10 to P2-17 and P2-18 to P2-22.

Please refer to the following Table 3.1 for the settings.

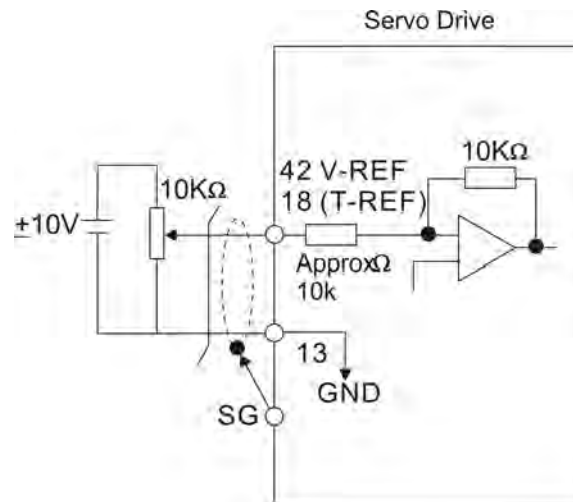
Table 3.1 User-defined DI and DO signals

Signal Name		Pin No.	Parameters	Signal Name		Pin No.	Parameters
Standard DI	DI1-	Pin 9 of CN1	P2-10	Standard DO	DO1+	Pin 7 of CN1	P2-18
	DI2-	Pin 10 of CN1	P2-11		DO1-	Pin 6 of CN1	
	DI3-	Pin 34 of CN1	P2-12		DO2+	Pin 5 of CN1	P2-19
	DI4-	Pin 8 of CN1	P2-13		DO2-	Pin 4 of CN1	
	DI5-	Pin 33 of CN1	P2-14		DO3+	Pin 3 of CN1	P2-20
	DI6-	Pin 32 of CN1	P2-15		DO3-	Pin 2 of CN1	
	DI7-	Pin 31 of CN1	P2-16		DO4+	Pin 1 of CN1	P2-21
	DI8-	Pin 30 of CN1	P2-17		DO4-	Pin 26 of CN1	
Extension DI	EDI9	Pin 2 of CN7	P2-36	DO5+	Pin 28 of CN1	P2-22	
	EDI10	Pin 3 of CN7	P2-37	DO5-	Pin 27 of CN1		
	EDI11	Pin 4 of CN7	P2-38				
	EDI12	Pin 5 of CN7	P2-39				
	EDI13	Pin 6 of CN7	P2-40				
	EDI14	Pin 7 of CN7	P2-41				

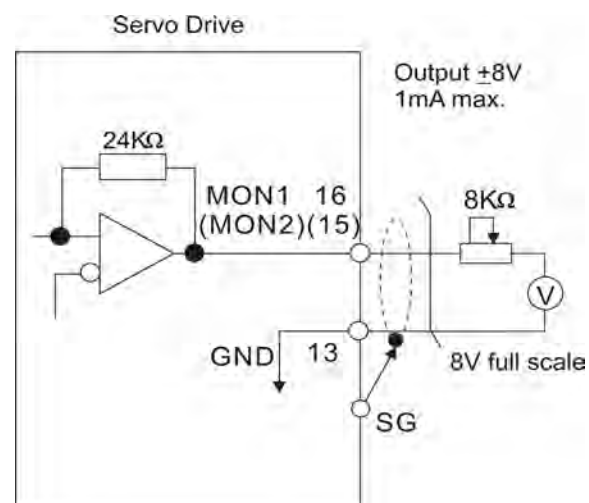
3.3.4 Wiring Diagrams of I/O Signals (CN1)

The valid voltage range of analog input command in speed and torque mode is $-10V \sim +10V$. The command value can be set via relevant parameters. The value of input impedance is $10k\Omega$.

C1: Speed / Torque analog signal input

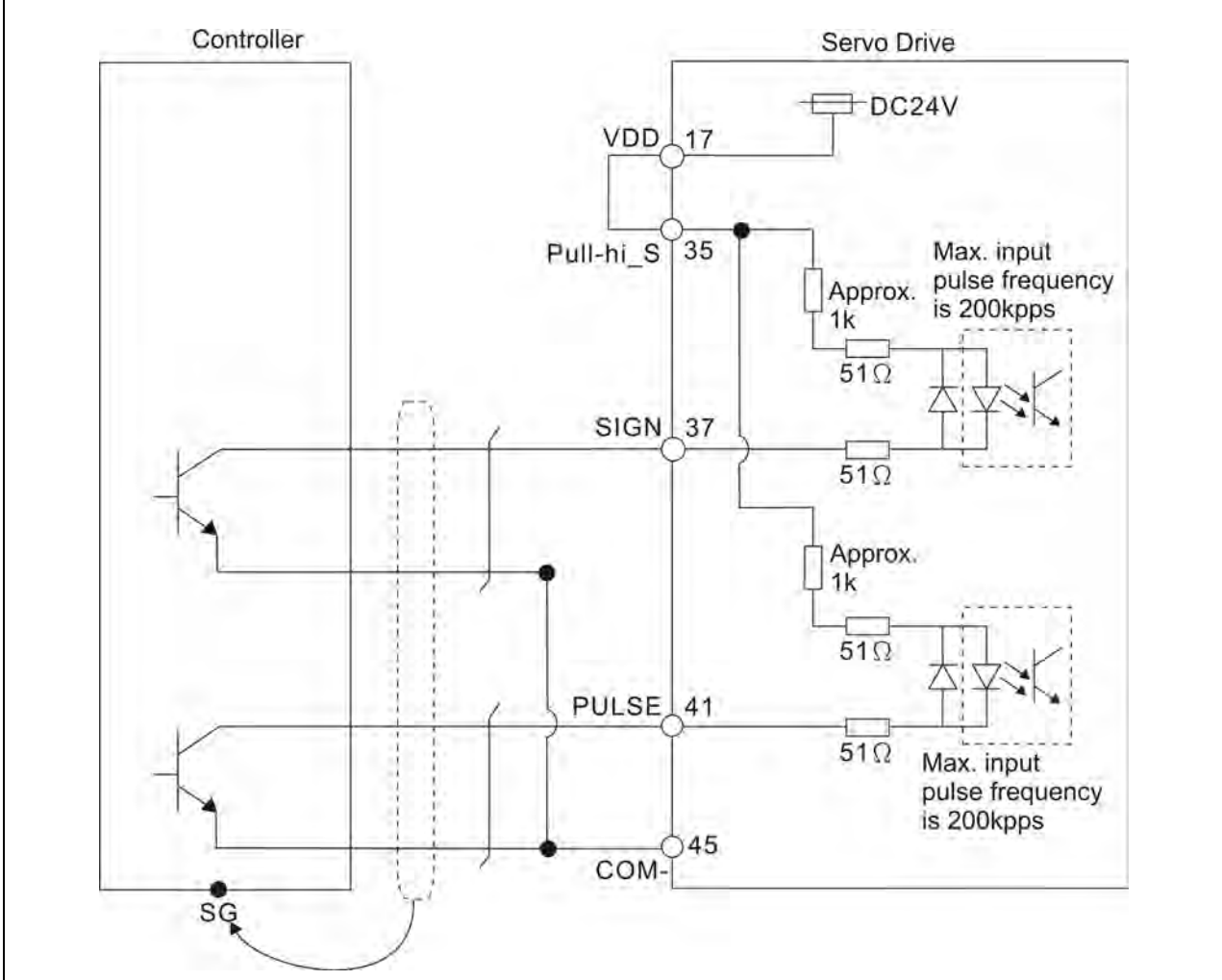


C2: Analog monitor output (MON1, MON2)

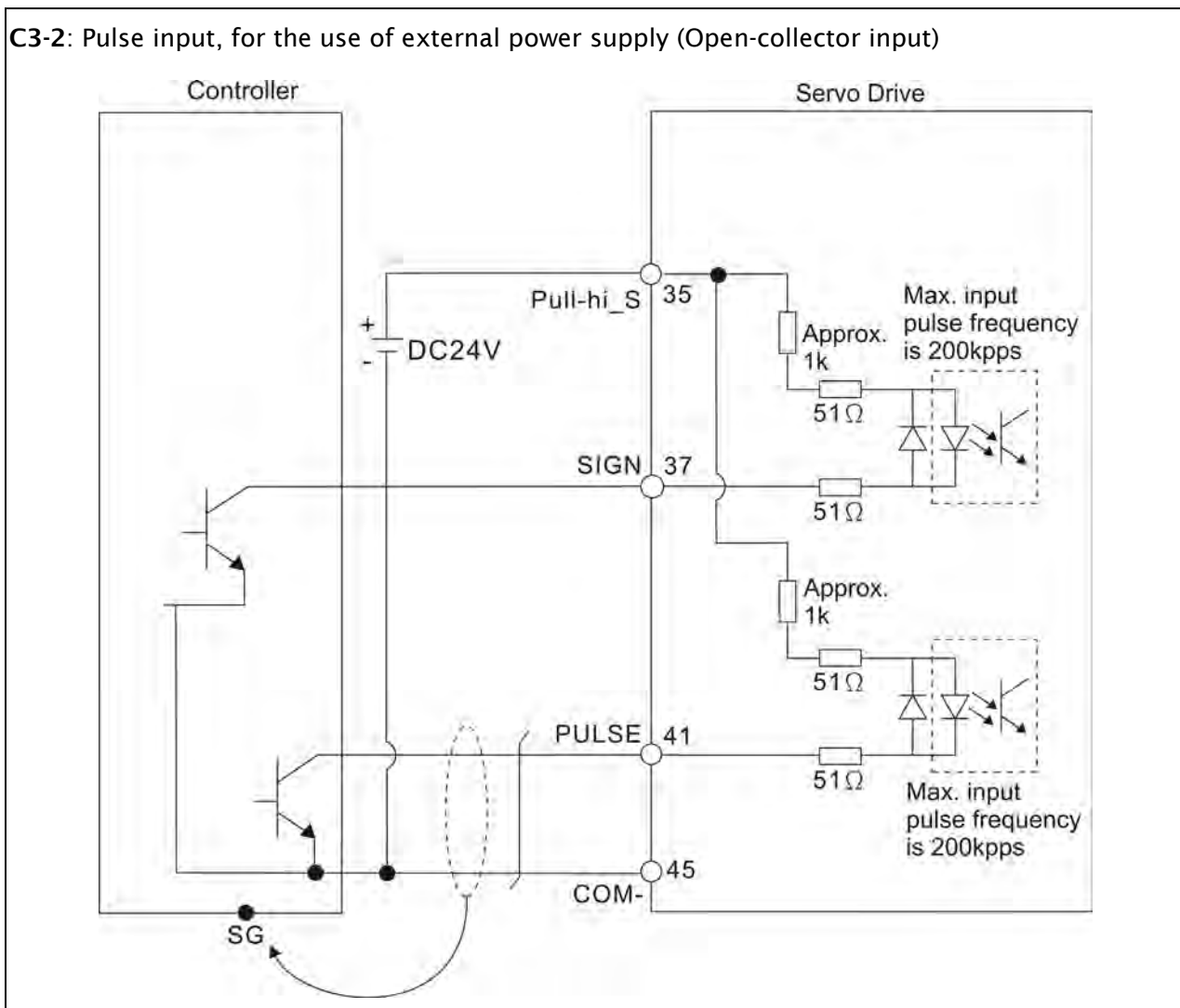


There are two kinds of pulse inputs, Line driver input and Open-collector input. Max. input pulse frequency of Line-driver input is 500kpps and max. input pulse frequency of Open-collector input is 200kpps.

C3-1: Pulse input, for the use of internal power supply (Open-collector input)

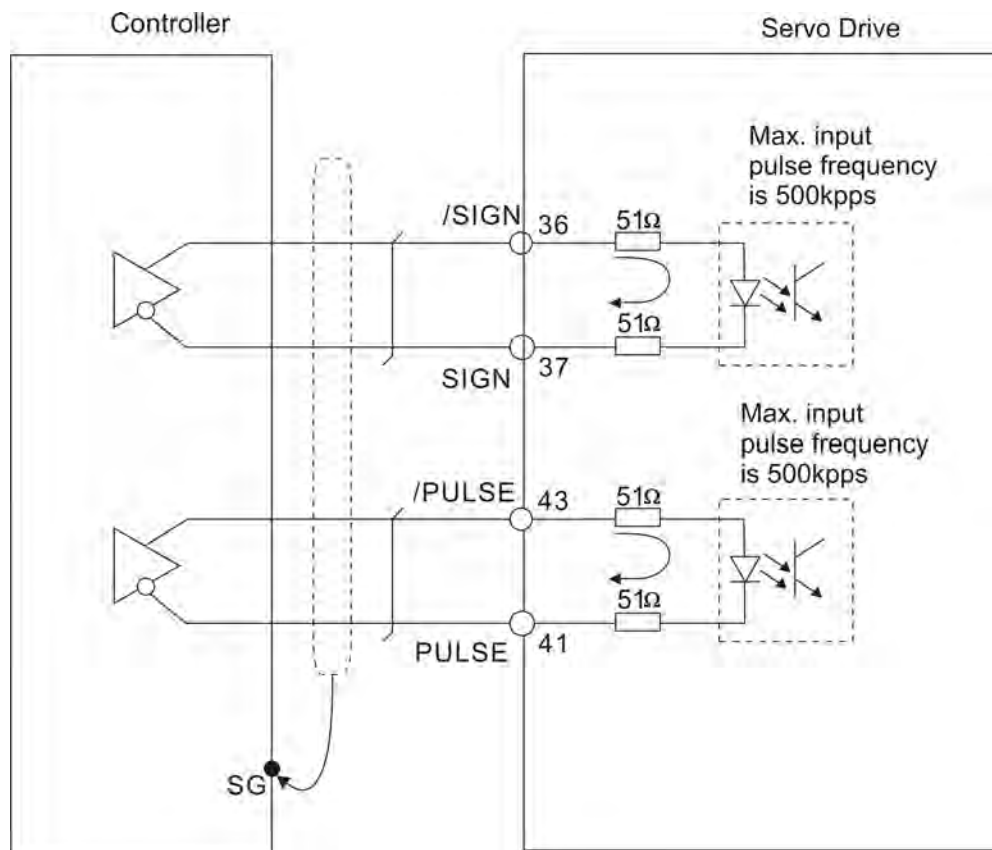


C3-2: Pulse input, for the use of external power supply (Open-collector input)

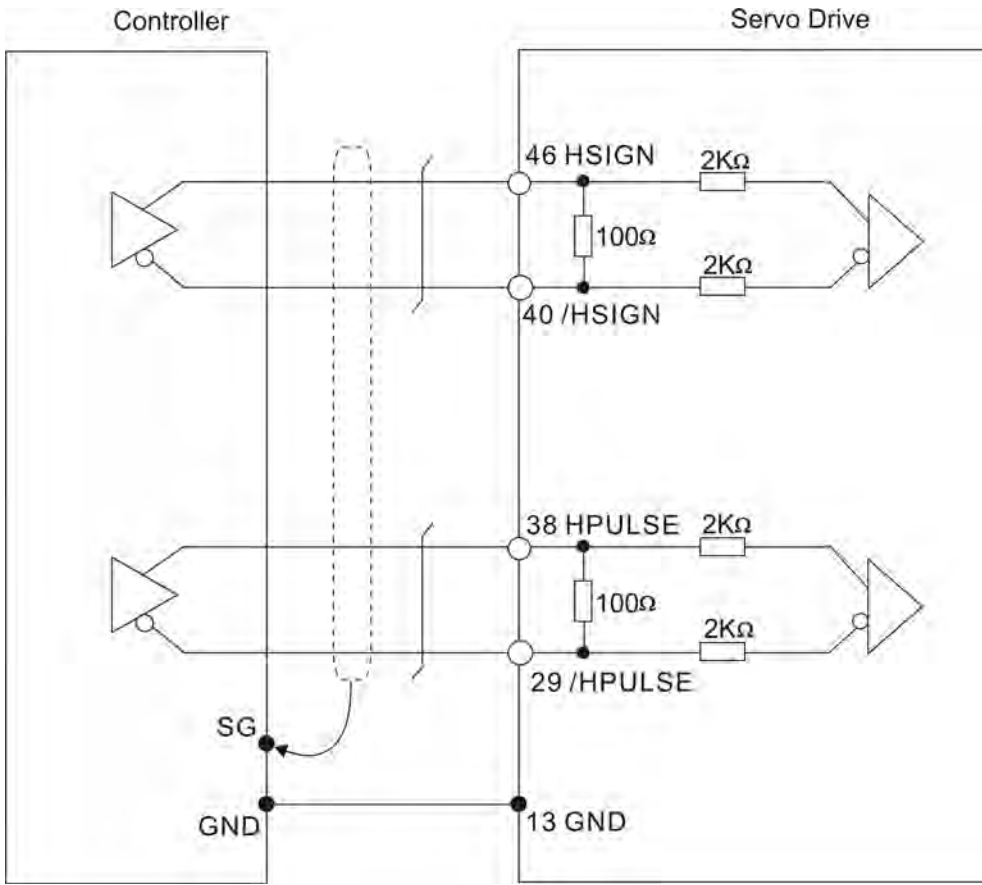


➤ **Caution:** Do not use dual power supply. Failure to observe this caution may result in damage to the servo drive and servo motor.

C4-1: Pulse input (Line driver input). It requires 5V power supply only. Never apply a 24V power supply.



C4-2: High-speed pulse input (Line driver). It requires 5V power supply only. Never apply a 24V power supply.

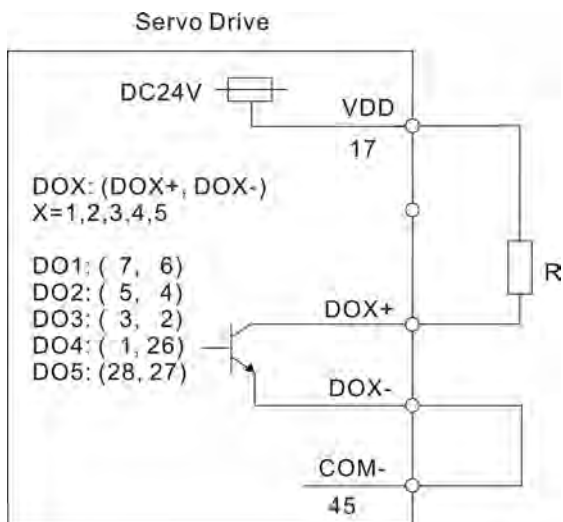


➤ **Caution:** Ensure that the ground terminal of the controller and the servo drive should be connected to each other.

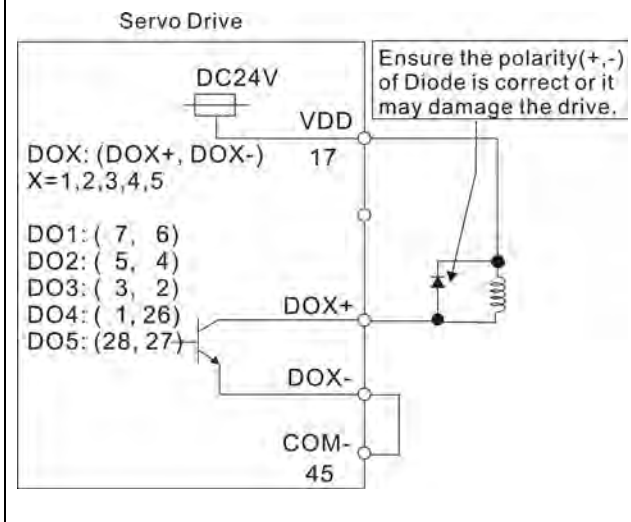
Be sure to connect a diode when the drive is applied to inductive load.

(Permissible current: 40mA, Instantaneous peak current: max. 100mA)

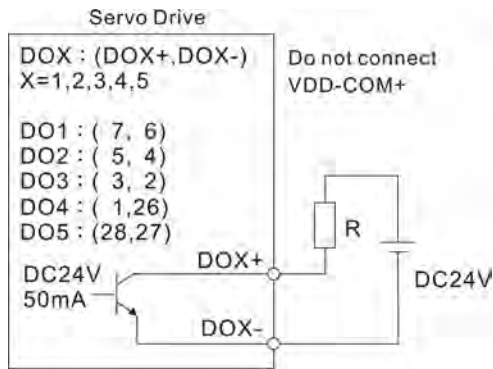
C5: Wiring of DO signal, for the use of internal power supply, general load



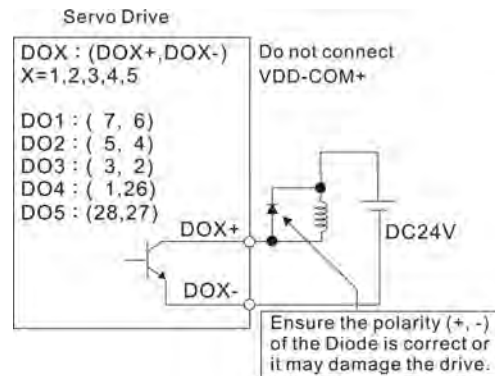
C6: Wiring of DO signal, for the use of internal power supply, inductive load



C7: Wiring of DO signal, for the use of external power supply, general load



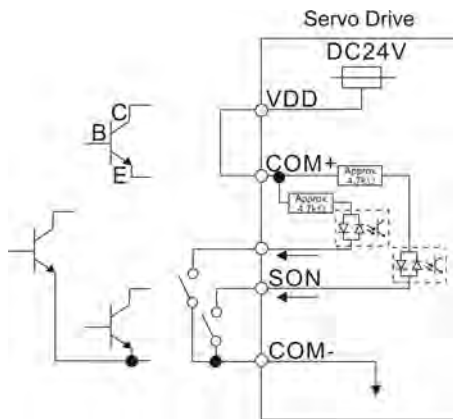
C8: Wiring of DO signal, for the use of external power supply, inductive load



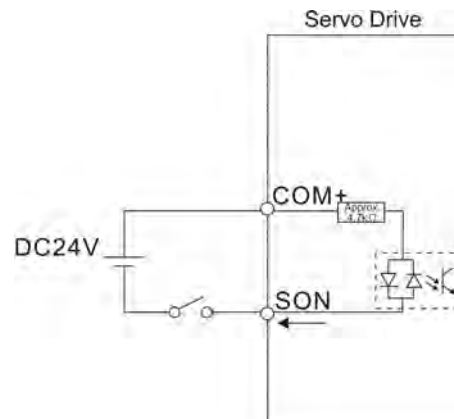
Use a relay or open-collector transistor to input signal.

NPN transistor with multiple emitter fingers (SINK Mode)

C9: Wiring of DI signal, for the use of internal power supply

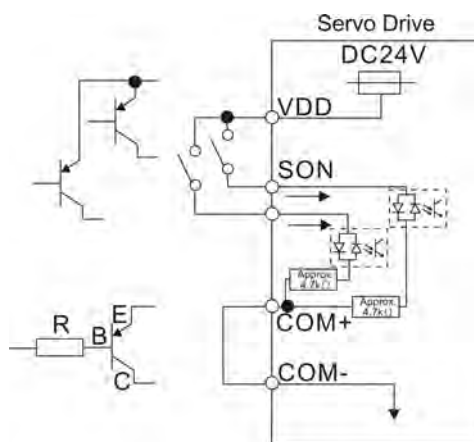


C10: Wiring of DI signal, for the use of external power supply

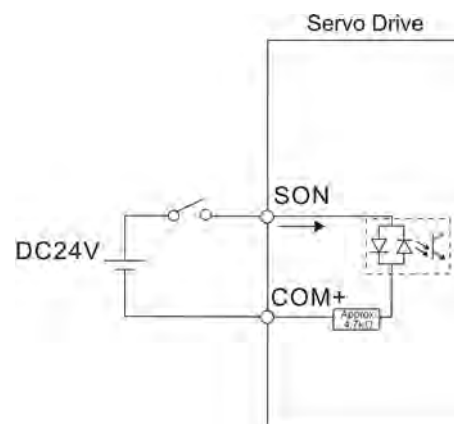


PNP transistor with multiple emitter fingers (SOURCE Mode)

C11: Wiring of DI signal, for the use of internal power supply

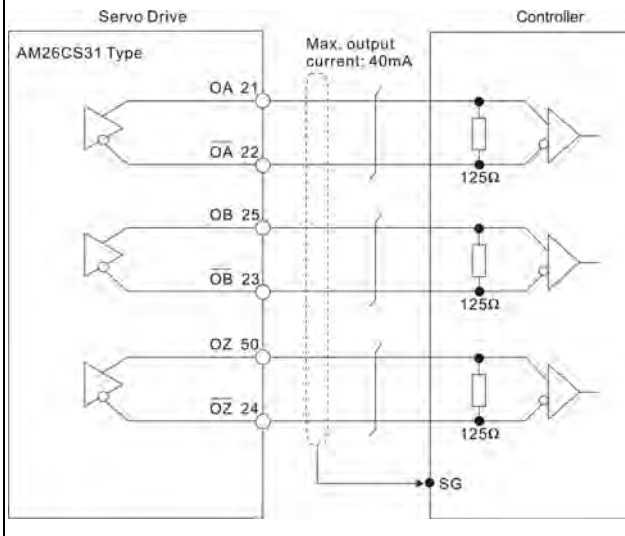


C12: Wiring of DI signal, for the use of external power supply

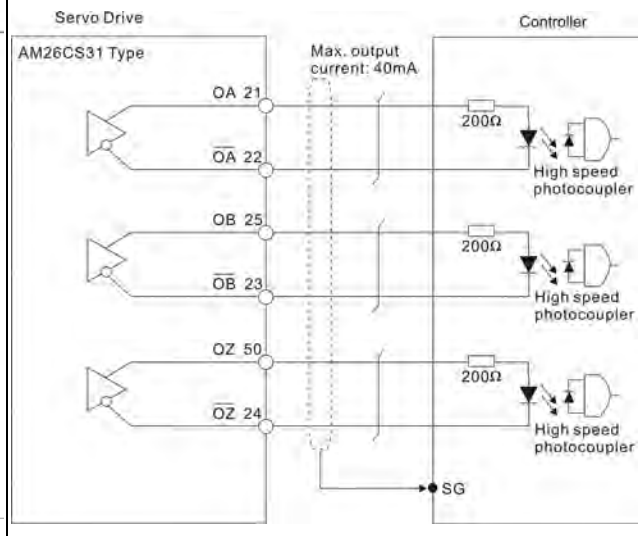


➤ **Caution: Do not use dual power supply. Failure to observe this caution may result in damage to the servo drive and servo motor.**

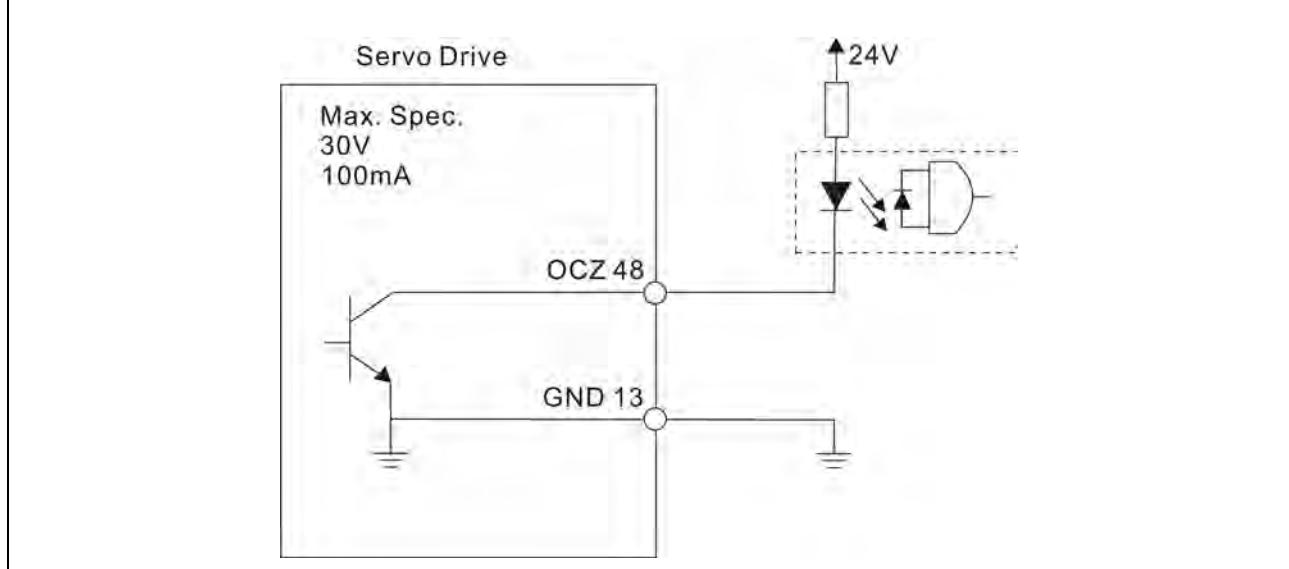
C13: Encoder output signal (Line driver)



C14: Encoder output signal (Photocoupler)



C15: Encoder OCZ output (Open-collector Z-pulse output)



3.5 Encoder Connector CN2

Feedback to the amplifier of the UVW signals for commutation is via the ABZ encoder signal wires. Following rotor position sensing the amplifier automatically switches to encoding for commutation control.

The 20-bit encoder is automatically multiplied to 1280000ppr for increased control accuracy.

Figure 3.12 The layout of CN2 Drive Connector

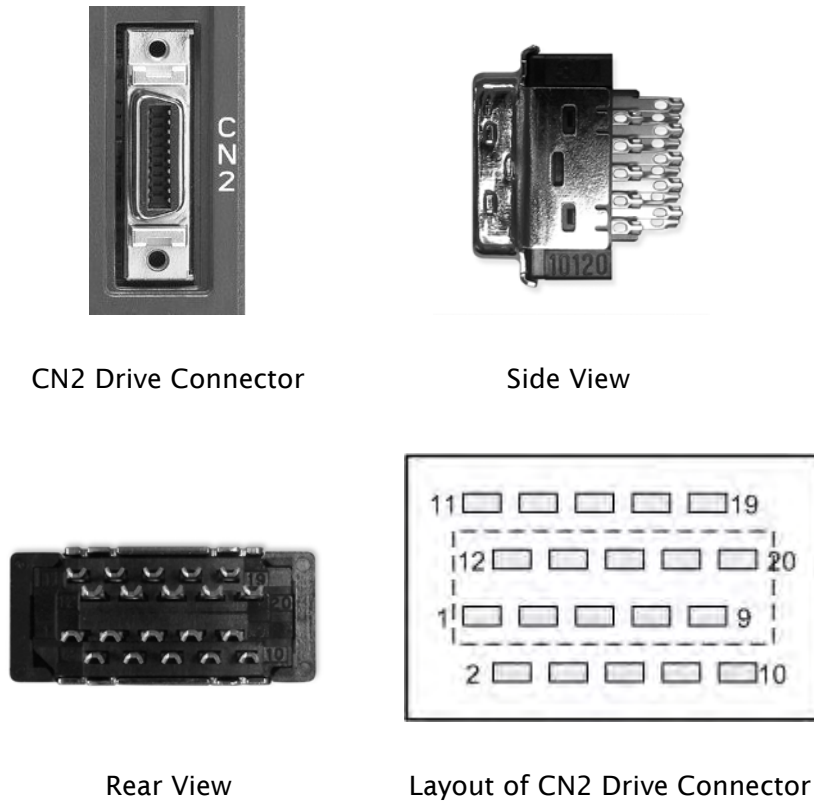
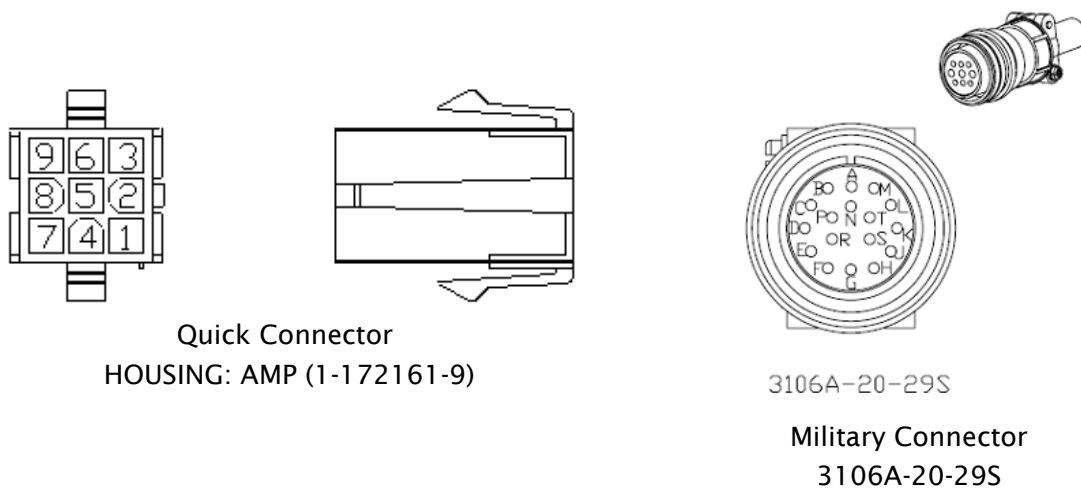


Figure 3.13 The layout of CN2 Motor Connector



CN2 Terminal Signal Identification

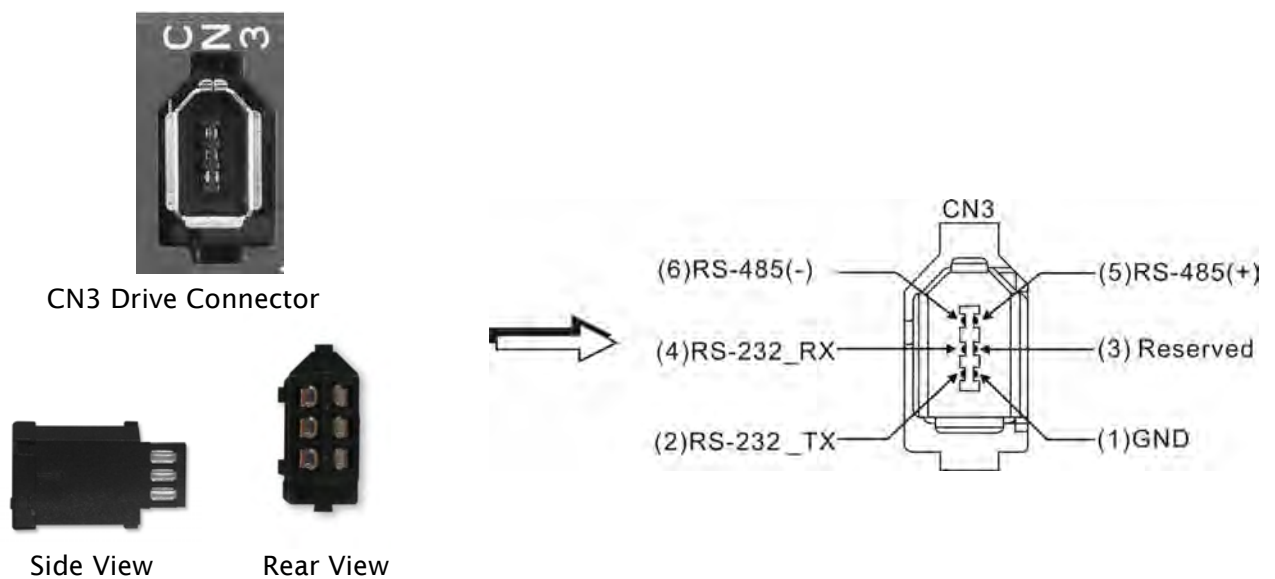
Drive Connector			Motor Connector		
PIN No.	Terminal Identification	Description	Military Connector	Quick Connector	Color
5	T+	Serial communication signal input / output (+)	A	1	Blue
4	T-	Serial communication signal input / output (-)	B	4	Blue/Black
-	-	Reserved	-	-	-
-	-	Reserved	-	-	-
14,16	+5V	+5V power supply	S	7	Red & Red/White
13,15	GND	Ground	R	8	Black & Black/White
-	-	Shielding	L	9	-

3.6 Serial Communication Connector CN3

3.6.1 CN3 Terminal Layout and Identification

The servo drive can be connected to a PC or controller via this serial communication connector CN3. Users can operate the servo drive through PC software supplied by Delta. The communication connector/port of Delta servo drive can provide two common serial communication interfaces: RS-232 and RS-485 connection. RS-232 is mostly be used but is somewhat limited. The maximum cable length for an RS-232 connection is 15 meters (50 feet). Using RS-485 interface can allow longer distance for transmission and support multiple drives to be connected simultaneously.

Figure 3.14 The layout of CN3 Drive Connector



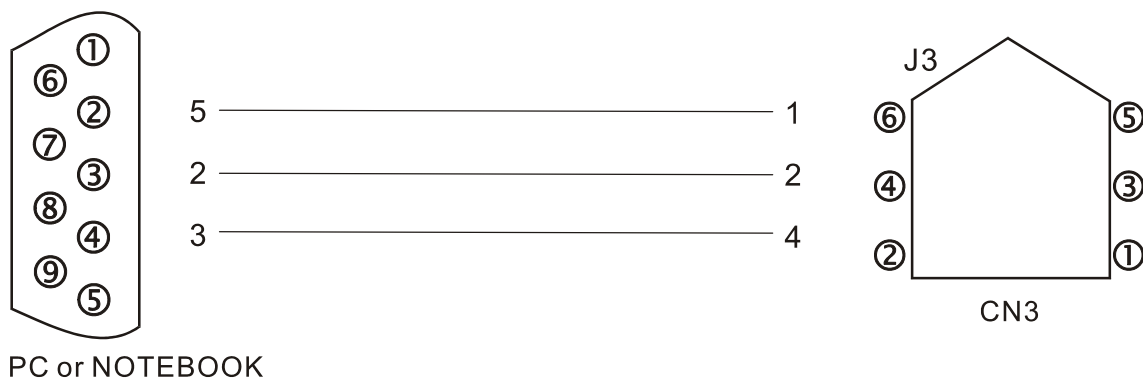
CN3 Terminal Signal Identification

PIN No.	Signal Name	Terminal Identification	Description
1	Grounding	GND	Ground
2	RS-232 data transmission	RS-232_TX	For data transmission of the servo drive. Connected to the RS-232 interface of PC.
3	-	-	Reserved
4	RS-232 data receiving	RS-232_RX	For data receiving of the servo drive. Connected to the RS-232 interface of PC.
5	RS-485 data transmission	RS-485(+)	For data transmission of the servo drive (differential line driver + end)
6	RS-485 data transmission	RS-485(-)	For data transmission of the servo drive (differential line driver - end)

 **NOTE**

- 1) For the connection of RS-485, please refer to page 9.3.
- 2) There are two kinds of IEEE1394 communication cables available on the market. If the user uses one kind of cable, which its GND terminal (Pin 1) and its shielding is short-circuited, the communication may be damaged. Never connect the case of the terminal to the ground of this kind of communication cable.

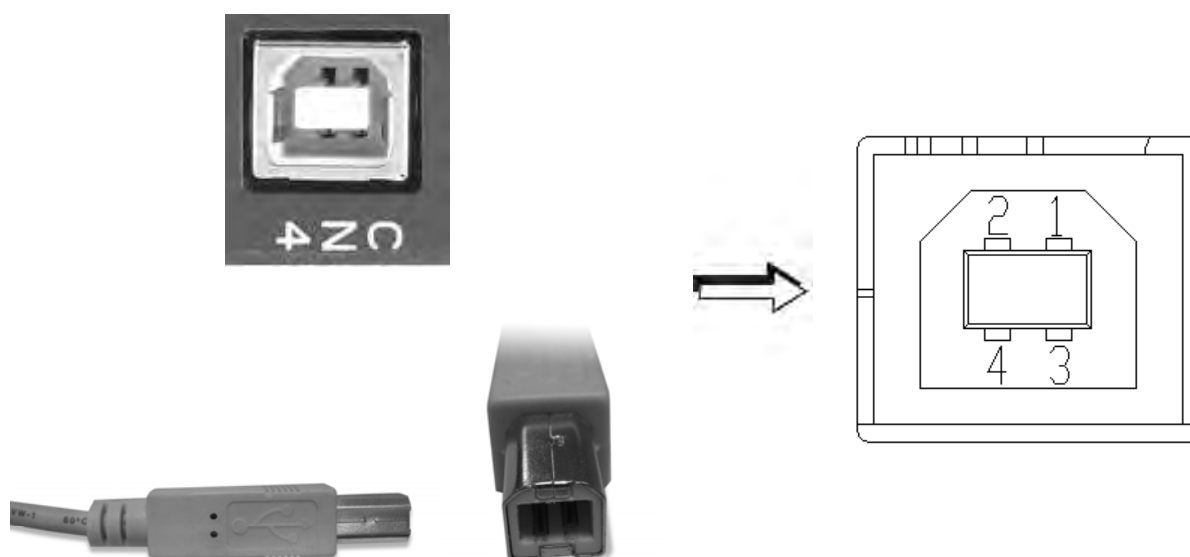
3.6.2 Connection between PC and Connector CN3



3.7 Serial Communication Connector CN4 (USB)

The servo drive can be connected to a PC via this serial communication connector CN4. Users can operate the servo drive through PC software supplied by Delta. The USB transmission speed can reach up to 1MB. Therefore, the users can easily monitor the servo drive data in real time by using Data Scope function provided by Delta PC software.

Figure 3.15 The layout of CN4 Drive Connector



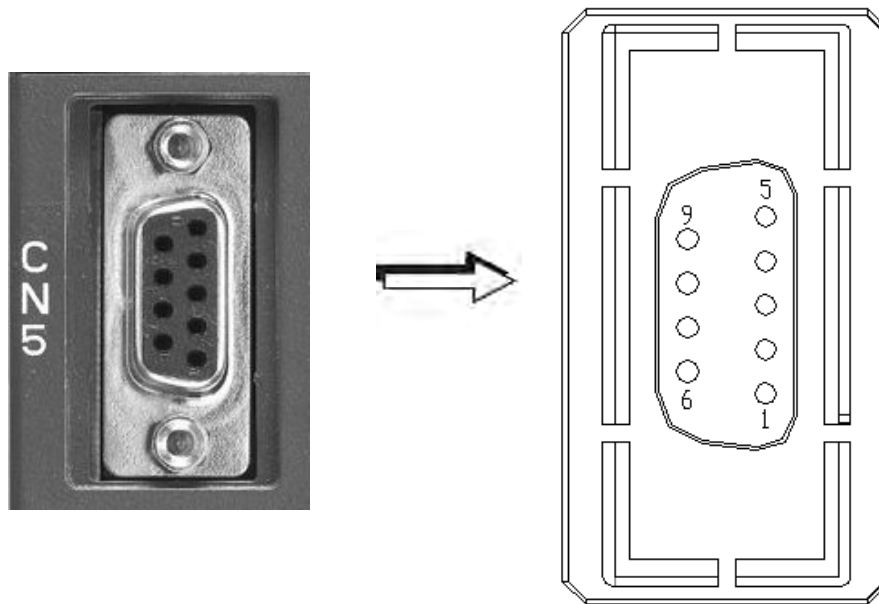
CN4 Terminal Signal Identification

PIN No.	Signal Name	Description
1	V bus	DC +5V (external power supply)
2	D-	Data-
3	D+	Data+
4	GND	Ground

3.8 Position Feedback Signal Connector CN5 (for Full-close Control)

The servo drive can be connected to a linear scale or external encoder to constitute a full-closed loop via this position feedback signal connector CN5. In position mode, the pulse position commands given by the external controller just refer to the control loop structure of the external linear scale. Please refer to Chapter 6 for more descriptions.

Figure 3.16 The layout of CN5 Drive Connector



CN5 Terminal Signal Identification

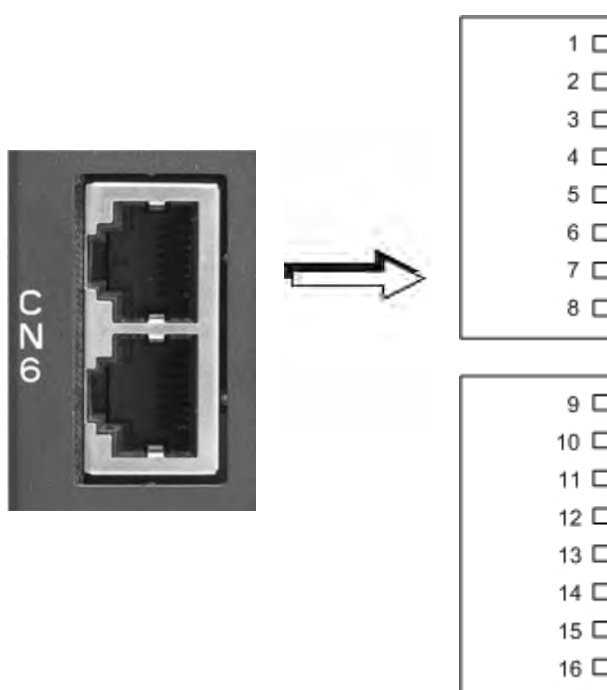
PIN No.	Signal Name	Terminal Identification	Description
1	/Z phase input	Opt_/Z	Linear scale /Z phase output
2	/B phase input	Opt_/B	Linear scale /B phase output
3	B phase input	Opt_B	Linear scale B phase output
4	A phase input	Opt_A	Linear scale A phase output
5	/A phase input	Opt_/A	Linear scale /A phase output
6	Encoder grounding	GND	Ground
7	Encoder grounding	GND	Ground
8	Encoder power	+5V	Linear scale 5V power
9	Z phase input	Opt_Z	Linear scale Z phase output

3.9 CANopen Communication Connector CN6

CANopen Communication Connector CN6 is designed in accordance with CANopen DS301 and DS402 implementation. With this connector CN6, the servo drive can be connected to a CAN device so as to perform position, speed and torque control, or read and monitor the status of the servo drive through CANopen communication.

The station numbers of CANopen communication are the same as RS-232 and RS-485 communication and all be determined by parameter P3-00. The transmission speed can be reached up to 1Mbps. There are two communication ports of connector CN6, one is for transmission and the other is for receiving, convenient for connecting to more than one servo drives in serial. Ensure to connect a termination resistor to the last connected servo drive.

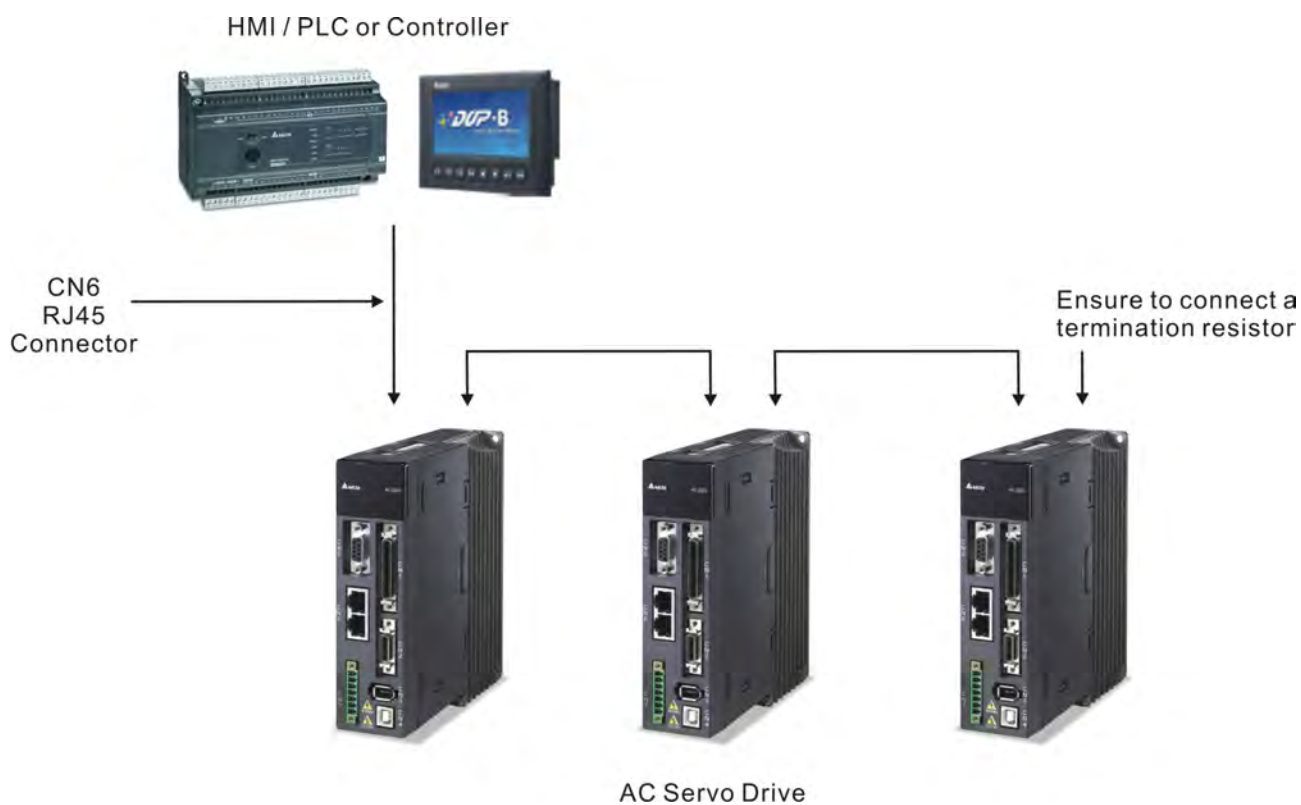
Figure 3.17 The layout of CN6 Drive Connector



CN6 Terminal Signal Identification

PIN No.	Signal Name	Description
1, 9	CAN_H	CAN_H bus line (dominant high)
2, 10	CAN_L	CAN_H bus line (dominant low)
3, 11	CAN_GND	Ground / 0 V / V -
4, 12	-	Reserved
5, 13	-	Reserved
6, 14	-	Reserved
7, 15	CAN_GND	Ground / 0 V / V -
8, 16	-	Reserved

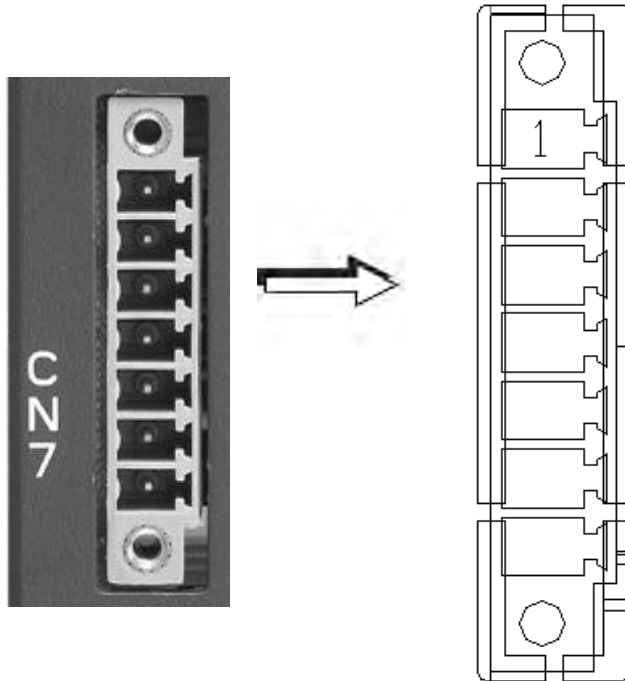
Figure 3.18 Connecting more than one servo drives via CANopen communication



3.10 Extension digital input connector CN7

ASDA-A2 series provides single-axis point-to-point position control function and the position numbers can be up to 64 points. When internal 8 programmable Digital Inputs (DI) which can be set via parameters P2-10 ~ P2-17 can not satisfied, the users can use this extension digital input connector CN7 to increase more digital inputs. Up to 6 programmable external Digital Inputs (DI) could be added.

Figure 3.19 The layout of CN7 Drive Connector



CN7 Terminal Signal Identification

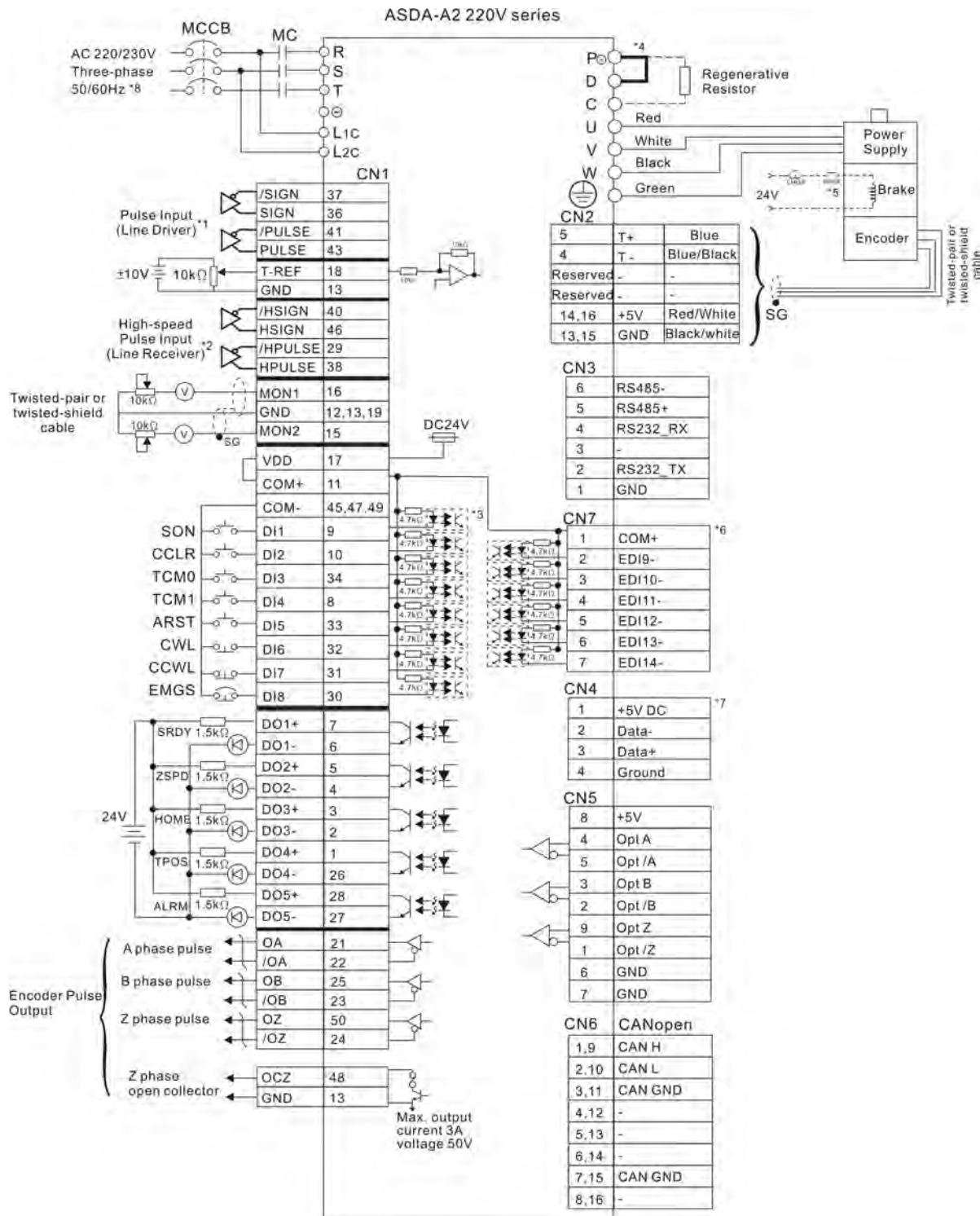
PIN No.	Signal Name	Terminal Identification	Description
1 ^(NOTE)	VDD 24V power	COM+	VDD (24V) power supply, same as Pin 11 of CN1
2	Extension DI9	EDI 9-	Digital input DI9-
3	Extension DI10	EDI 10-	Digital input DI10-
4	Extension DI11	EDI 11-	Digital input DI11-
5	Extension DI12	EDI 12-	Digital input DI12-
6	Extension DI13	EDI 13-	Digital input DI13-
7	Extension DI14	EDI 14-	Digital input DI14-



➤ **Caution: Do not use dual power supply. Failure to observe this caution may result in damage to the servo drive and servo motor.**

3.11 Standard Connection Example - 220V series

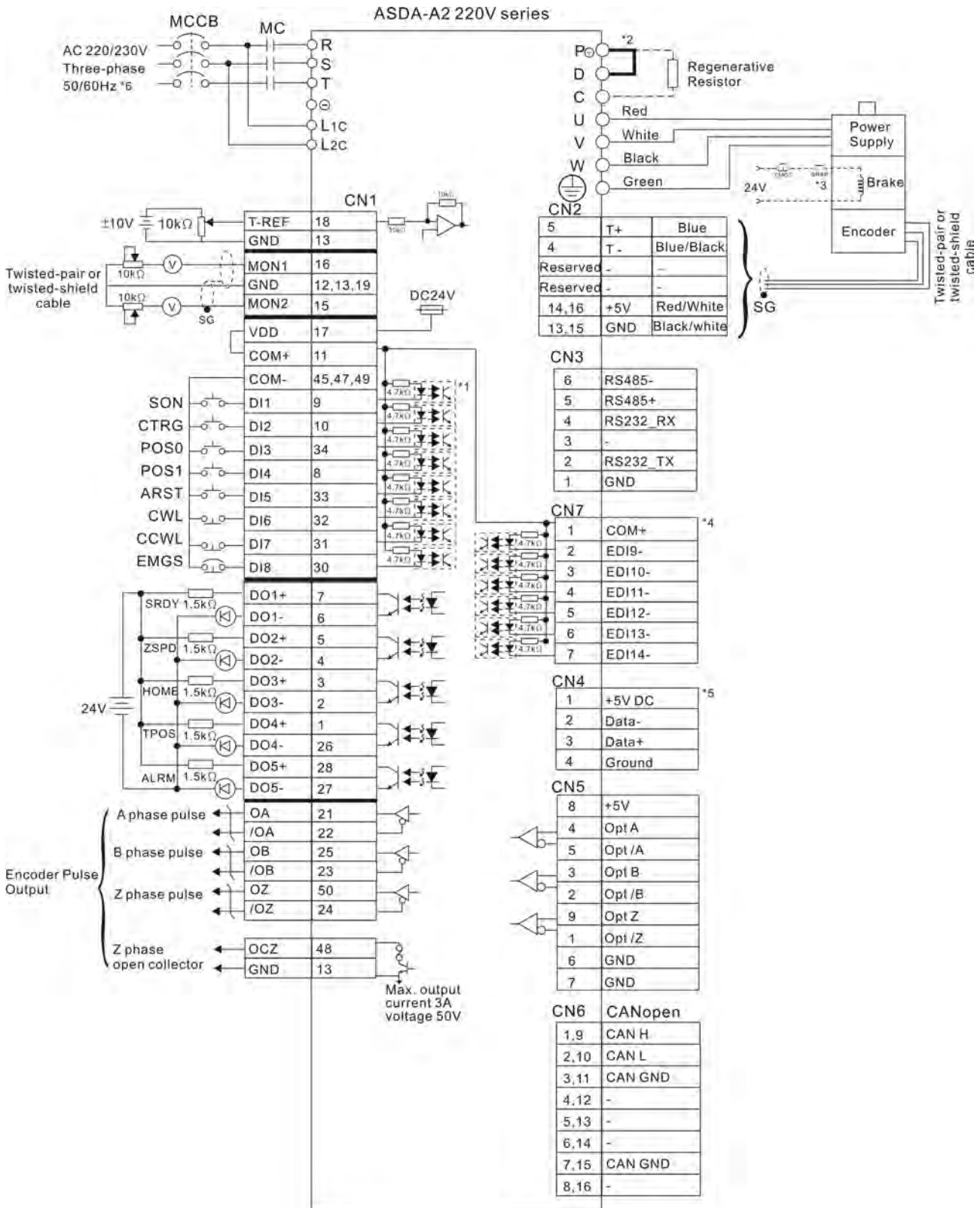
3.11.1 Position (PT) Control Mode



Please note:

- *1 Please refer to C3 ~ C4 wiring diagrams in section 3.4.4.
- *2 Please refer to C3 ~ C4 wiring diagrams in section 3.4.4.
- *3 Please refer to C9 ~ C12 wiring diagrams (SINK / SOURCE mode) in section 3.4.4.
- *4 400W and below drives do not provide built-in regenerative resistor.
- *5 The coil of brake has no polarity.
- *6 For extension digital inputs (DI) connections (CN7 is a optional part, not Delta standard supplied part.).
- *7 For USB connection. It is used to connect to personal computer or notebook.
- *8 Single -phase connections are for servo drives 1.5kW and below only.

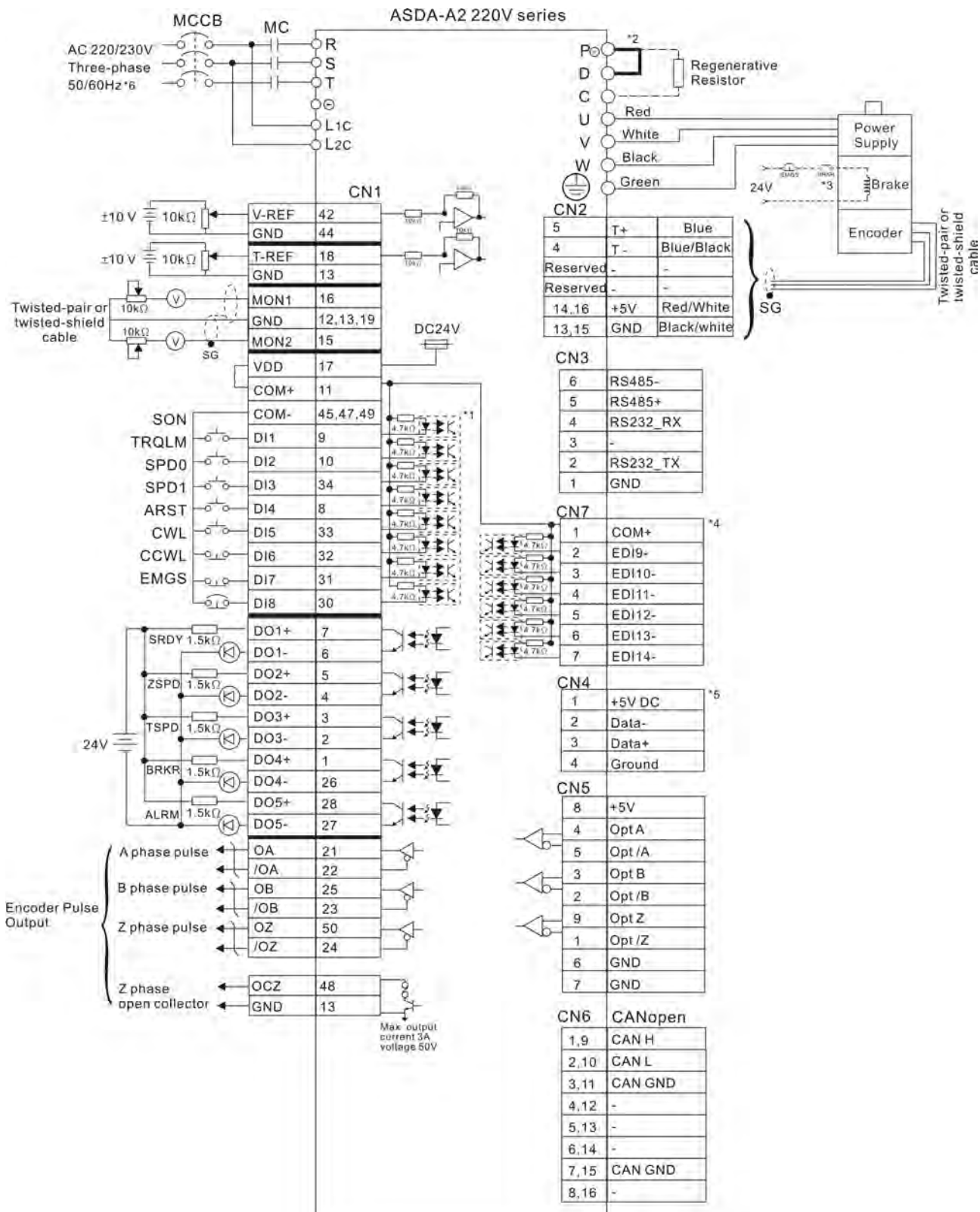
3.11.2 Position (PR) Control Mode



Please note:

- *1 Please refer to C9 ~ C12 wiring diagrams (SINK / SOURCE mode) in section 3.4.4.
- *2 400W and below drives do not provide built-in regenerative resistor.
- *3 The coil of brake has no polarity.
- *4 For extension digital inputs (DI) connections (CN7 is a optional part, not Delta standard supplied part.).
- *5 For USB connection. It is used to connect to personal computer or notebook.
- *6 Single -phase connections are for servo drives 1.5kW and below only.

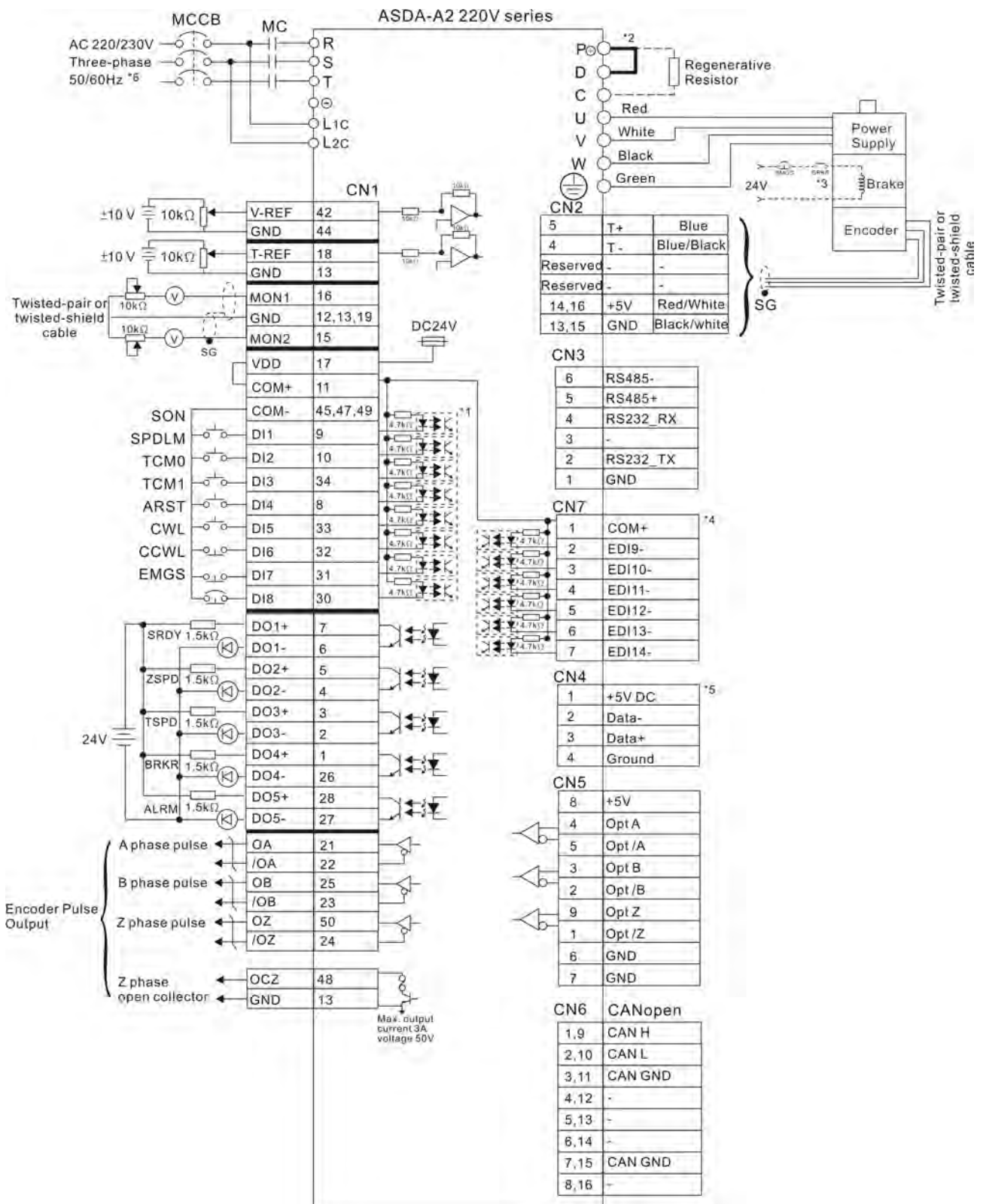
3.11.3 Speed Control Mode



Please note:

- *1 Please refer to C9 ~ C12 wiring diagrams (SINK / SOURCE mode) in section 3.4.4.
- *2 400W and below drives do not provide built-in regenerative resistor.
- *3 The coil of brake has no polarity.
- *4 For extension digital inputs (DI) connections (CN7 is a optional part, not Delta standard supplied part.).
- *5 For USB connection. It is used to connect to personal computer or notebook.
- *6 Single -phase connections are for servo drives 1.5kW and below only.

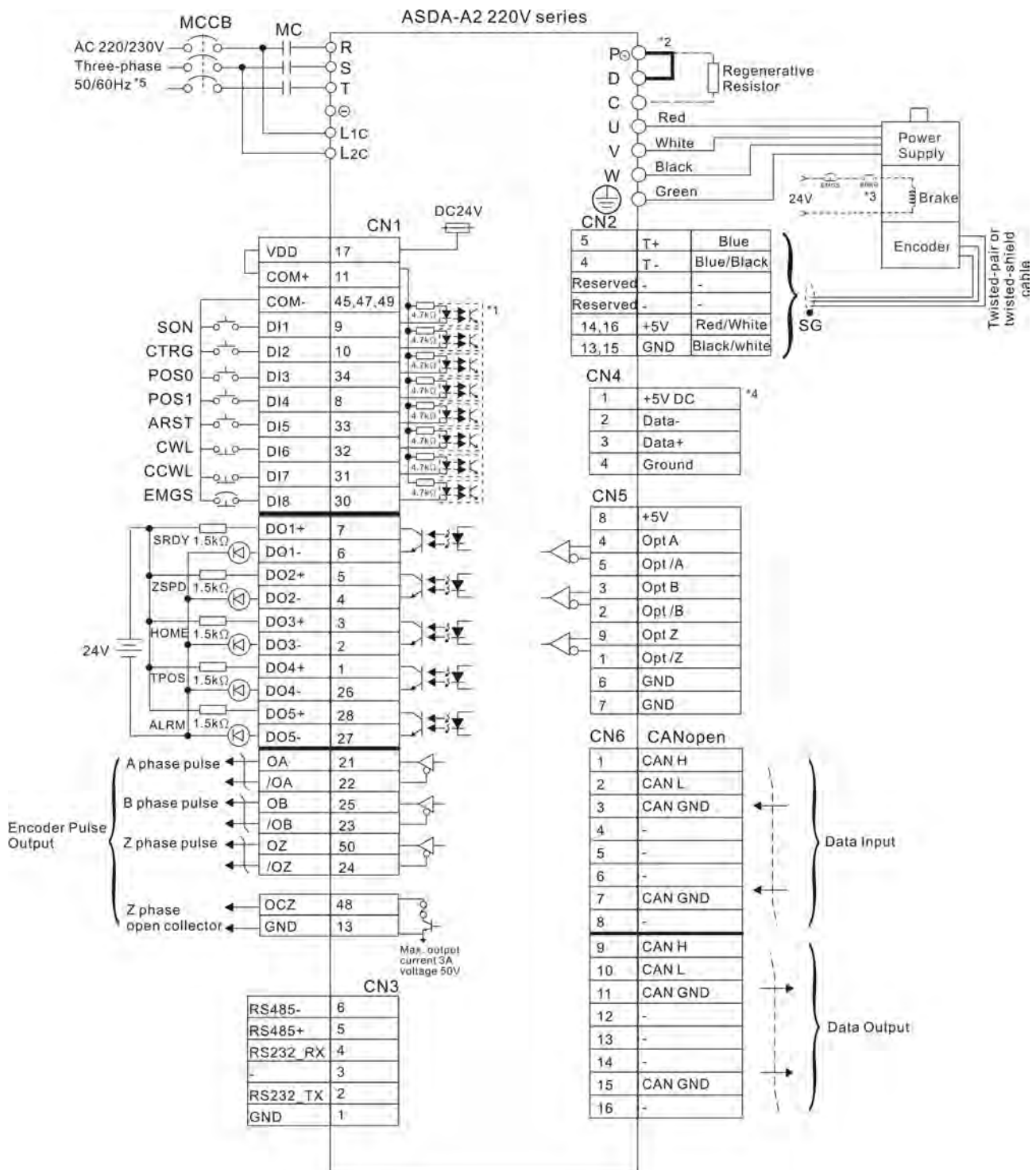
3.11.4 Torque Control Mode



Please note:

- *1 Please refer to C9 ~ C12 wiring diagrams (SINK / SOURCE mode) in section 3.4.4.
- *2 400W and below drives do not provide built-in regenerative resistor.
- *3 The coil of brake has no polarity.
- *4 For extension digital inputs (DI) connections (CN7 is a optional part, not Delta standard supplied part.).
- *5 For USB connection. It is used to connect to personal computer or notebook.
- *6 Single -phase connections are for servo drives 1.5kW and below only.

3.11.5 CANopen Communication Mode

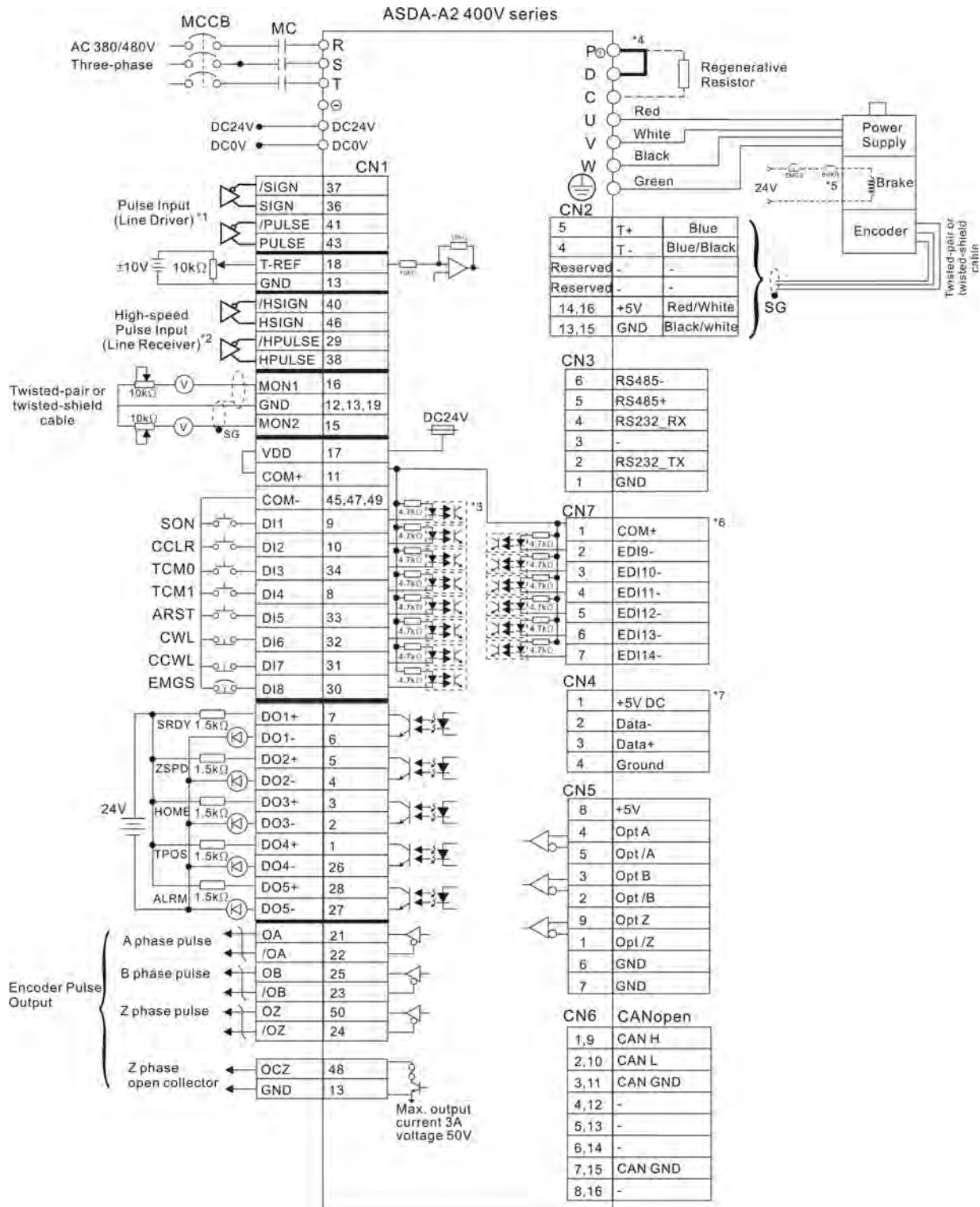


Please note:

- *1 Please refer to C9 ~ C12 wiring diagrams (SINK / SOURCE mode) in section 3.4.4.
- *2 400W and below drives do not provide built-in regenerative resistor.
- *3 The coil of brake has no polarity.
- *4 For USB connection. It is used to connect to personal computer or notebook.
- *5 Single -phase connections are for servo drives 1.5kW and below only.

3.12 Standard Connection Example - 400V series

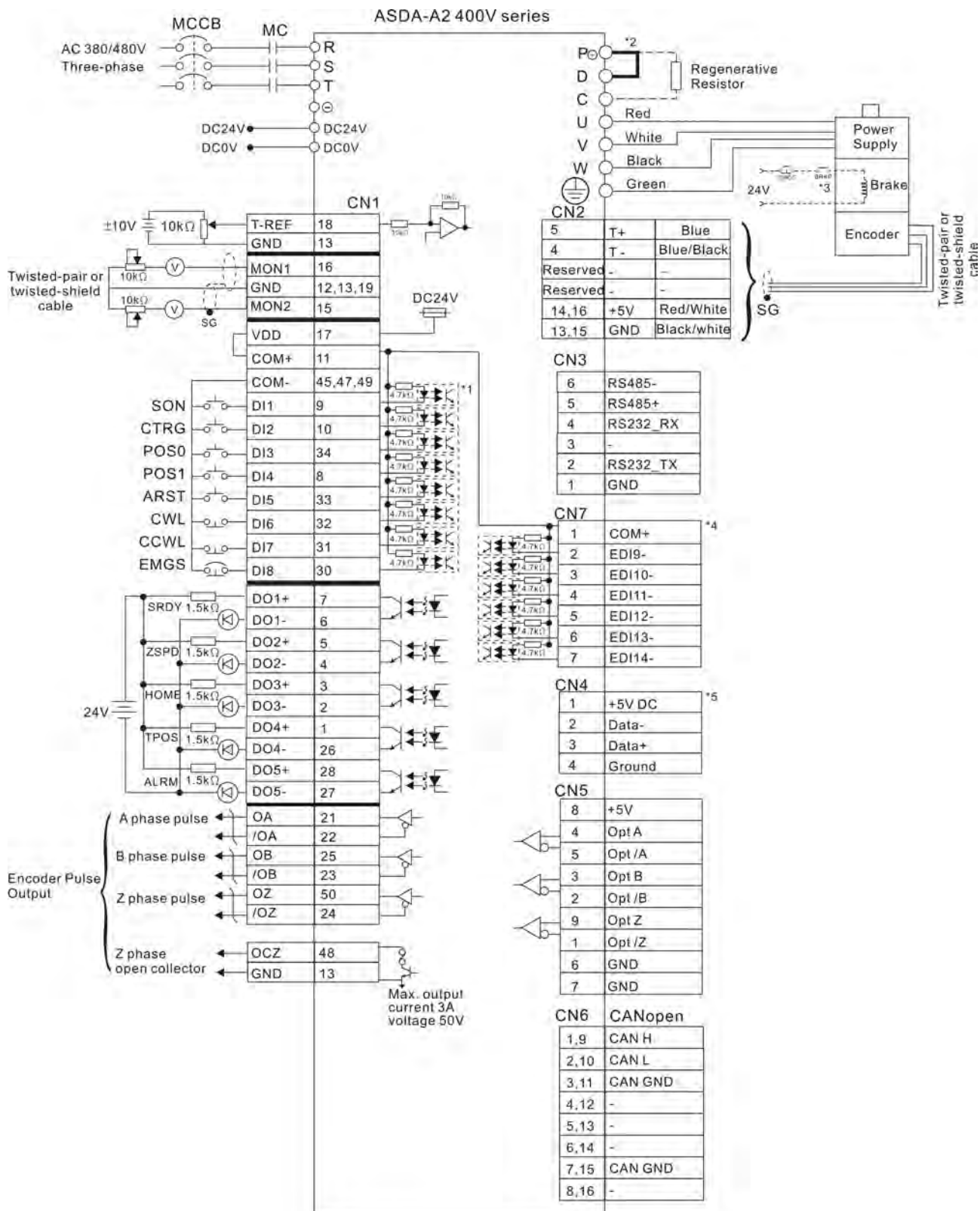
3.12.1 Position (PT) Control Mode



Please note:

- *1 Please refer to C3 ~ C4 wiring diagrams in section 3.4.4.
- *2 Please refer to C3 ~ C4 wiring diagrams in section 3.4.4.
- *3 Please refer to C9 ~ C12 wiring diagrams (SINK / SOURCE mode) in section 3.4.4.
- *4 400W and below drives do not provide built-in regenerative resistor.
- *5 The coil of brake has no polarity.
- *6 For extension digital inputs (DI) connections (CN7 is an optional part, not Delta standard supplied part.).
- *7 For USB connection. It is used to connect to personal computer or notebook.

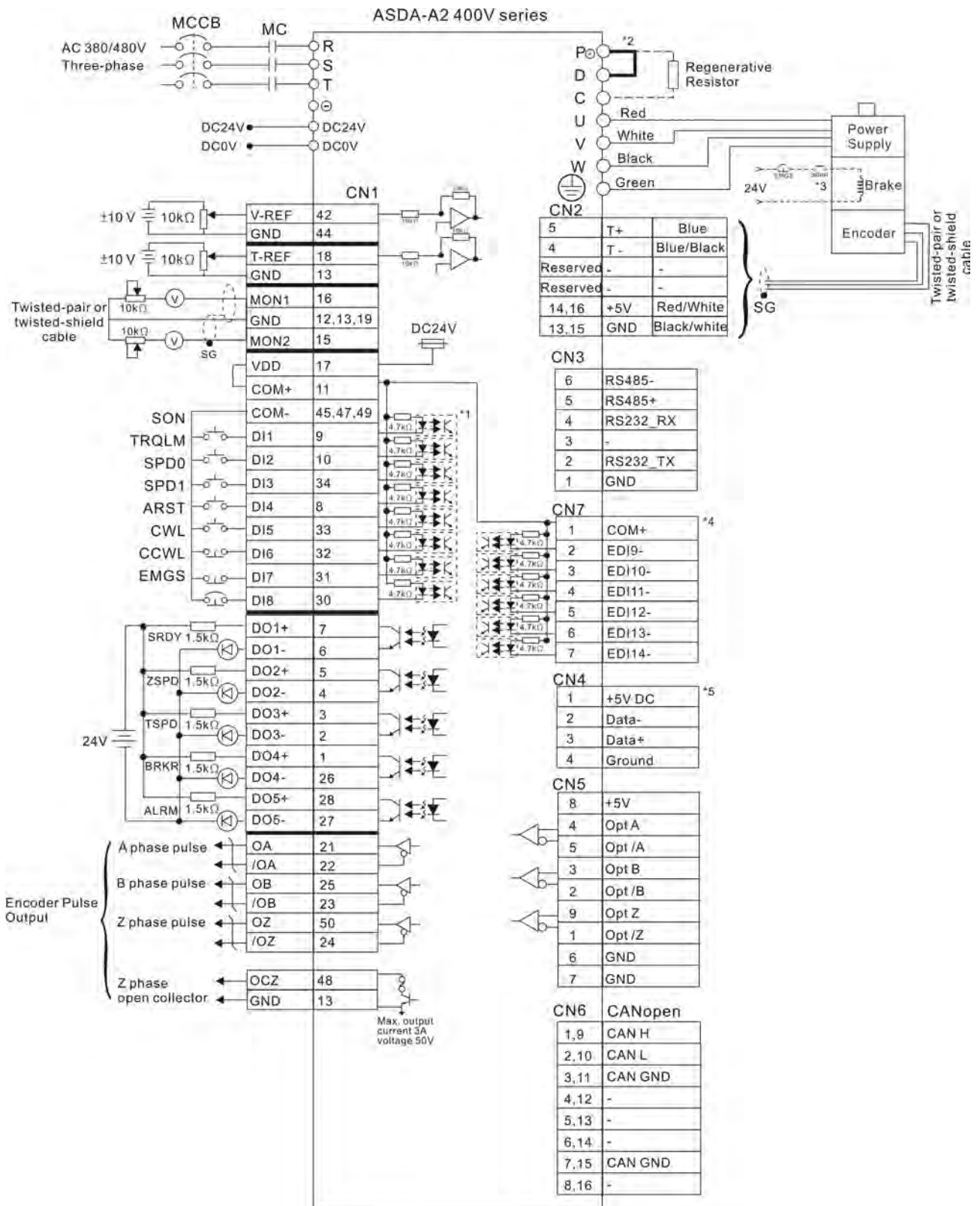
3.12.2 Position (PR) Control Mode



Please note:

- *1 Please refer to C9 ~ C12 wiring diagrams (SINK / SOURCE mode) in section 3.4.4.
- *2 400W and below drives do not provide built-in regenerative resistor.
- *3 The coil of brake has no polarity.
- *4 For extension digital inputs (DI) connections (CN7 is a optional part, not Delta standard supplied part.).
- *5 For USB connection. It is used to connect to personal computer or notebook.

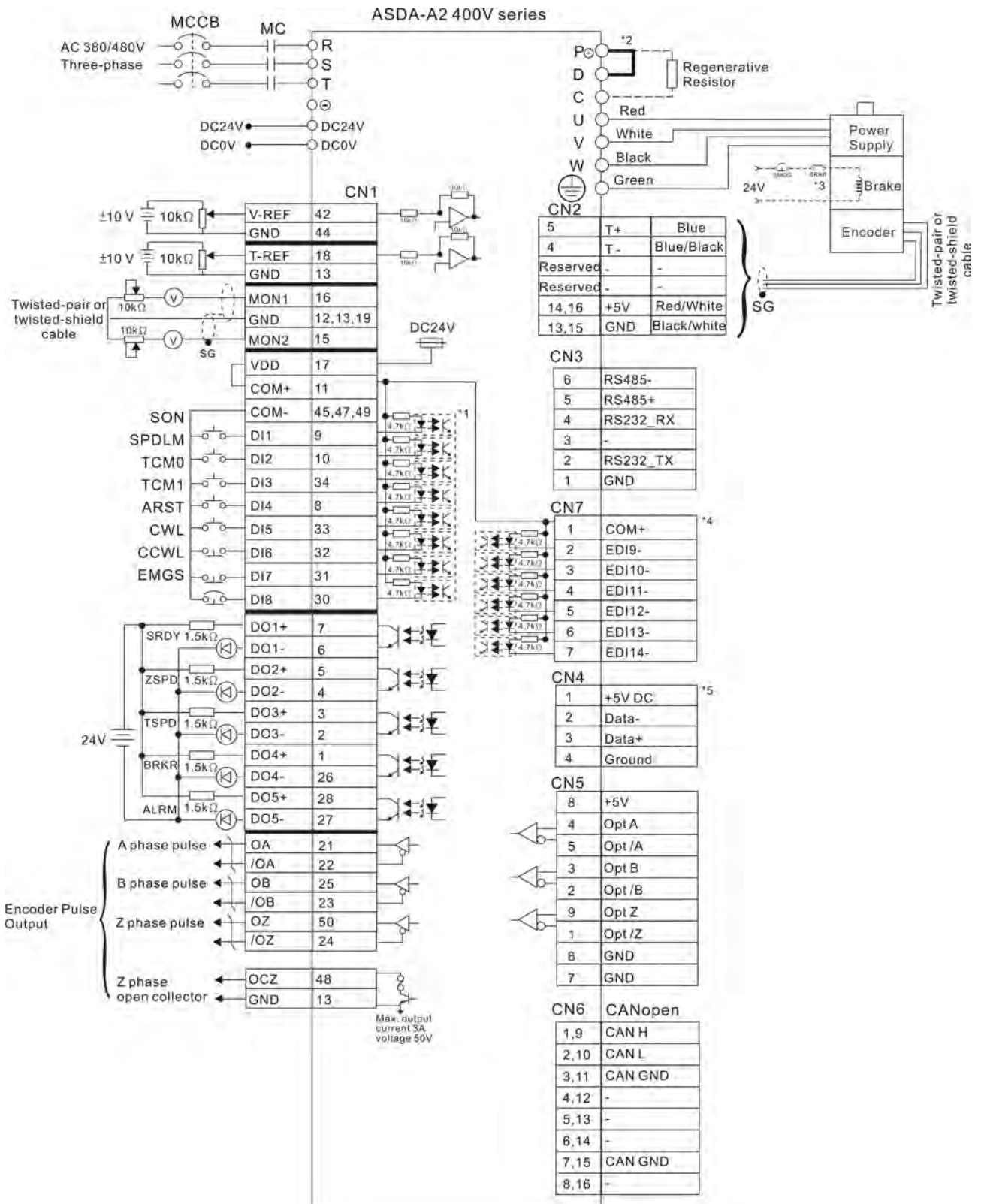
3.12.3 Speed Control Mode



Please note:

- *1 Please refer to C9 ~ C12 wiring diagrams (SINK / SOURCE mode) in section 3.4.4.
- *2 400W and below drives do not provide built-in regenerative resistor.
- *3 The coil of brake has no polarity.
- *4 For extension digital inputs (DI) connections (CN7 is a optional part, not Delta standard supplied part.).
- *5 For USB connection. It is used to connect to personal computer or notebook.

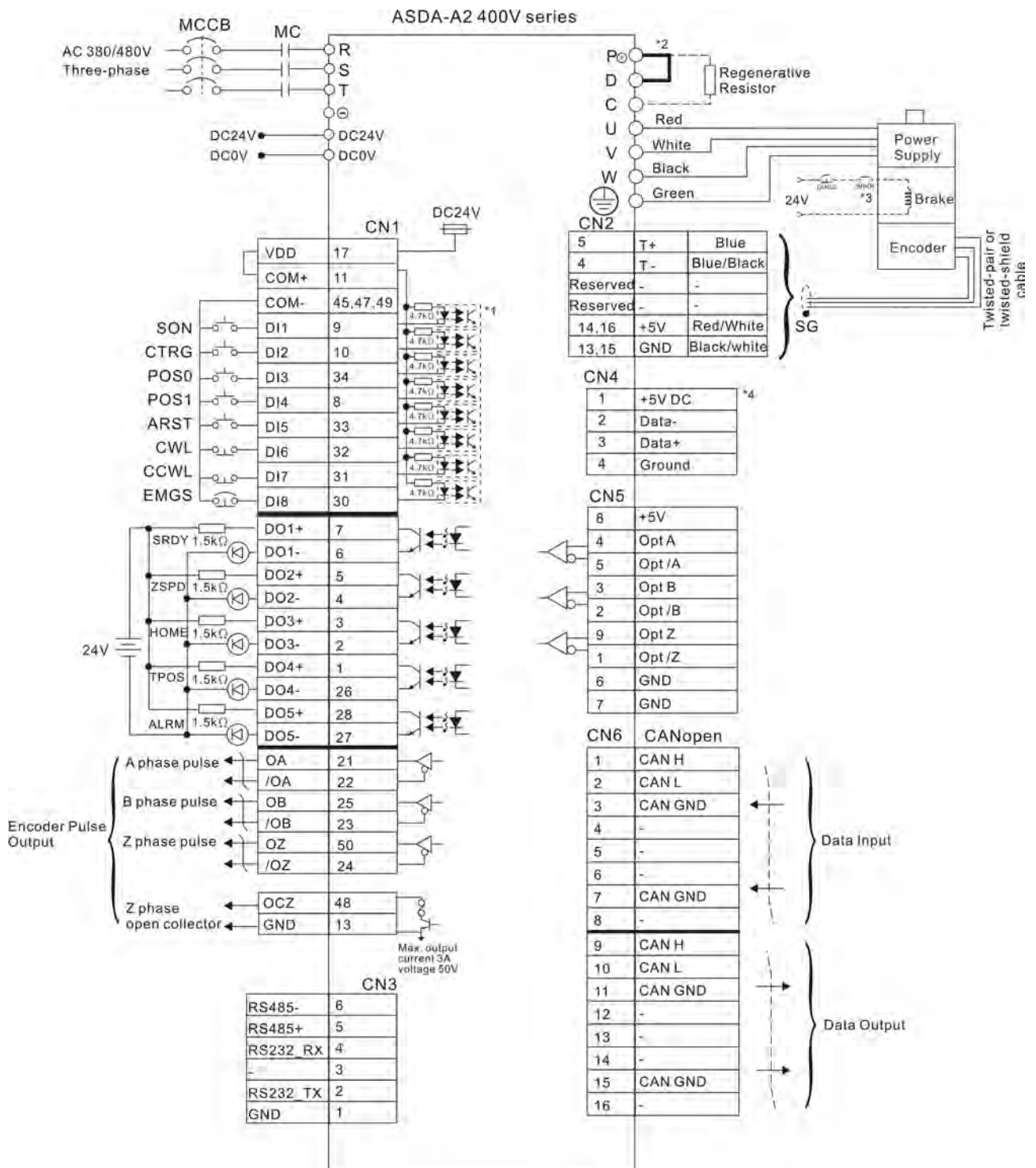
3.12.4 Torque Control Mode



Please note:

- *1 Please refer to C9 ~ C12 wiring diagrams (SINK / SOURCE mode) in section 3.4.4.
- *2 400W and below drives do not provide built-in regenerative resistor.
- *3 The coil of brake has no polarity.
- *4 For extension digital inputs (DI) connections (CN7 is a optional part, not Delta standard supplied part.).
- *5 For USB connection. It is used to connect to personal computer or notebook.

3.12.5 CANopen Communication Mode



Please note:

- *1 Please refer to C9 ~ C12 wiring diagrams (SINK / SOURCE mode) in section 3.4.4.
- *2 400W and below drives do not provide built-in regenerative resistor.
- *3 The coil of brake has no polarity.
- *4 For USB connection. It is used to connect to personal computer or notebook.

This page intentionally left blank.

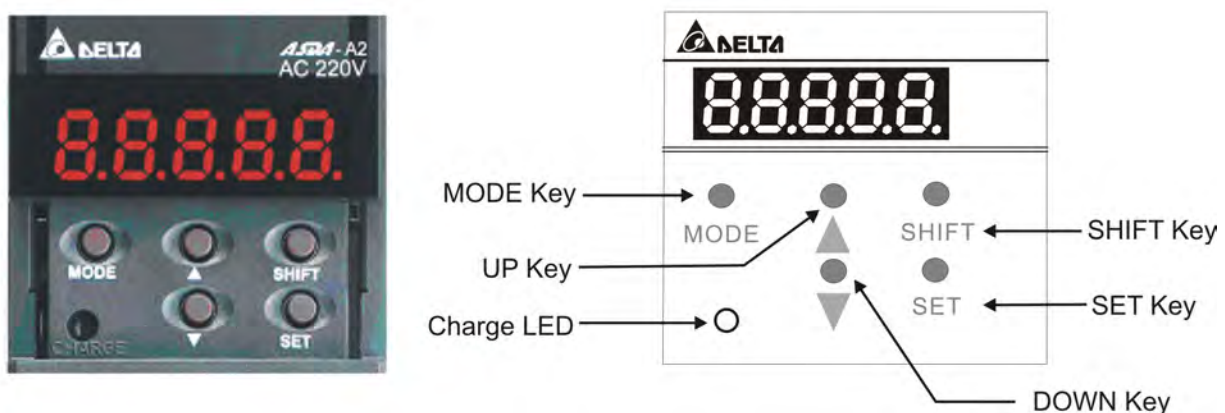
Chapter 4 Display and Operation

This chapter describes the basic operation of the digital keypad and the features it offers.

4.1 Description of the Digital Keypad

The digital keypad includes the display panel and function keys. The Figure 4.1 shows all of the features of the digital keypad and an overview of their functions.

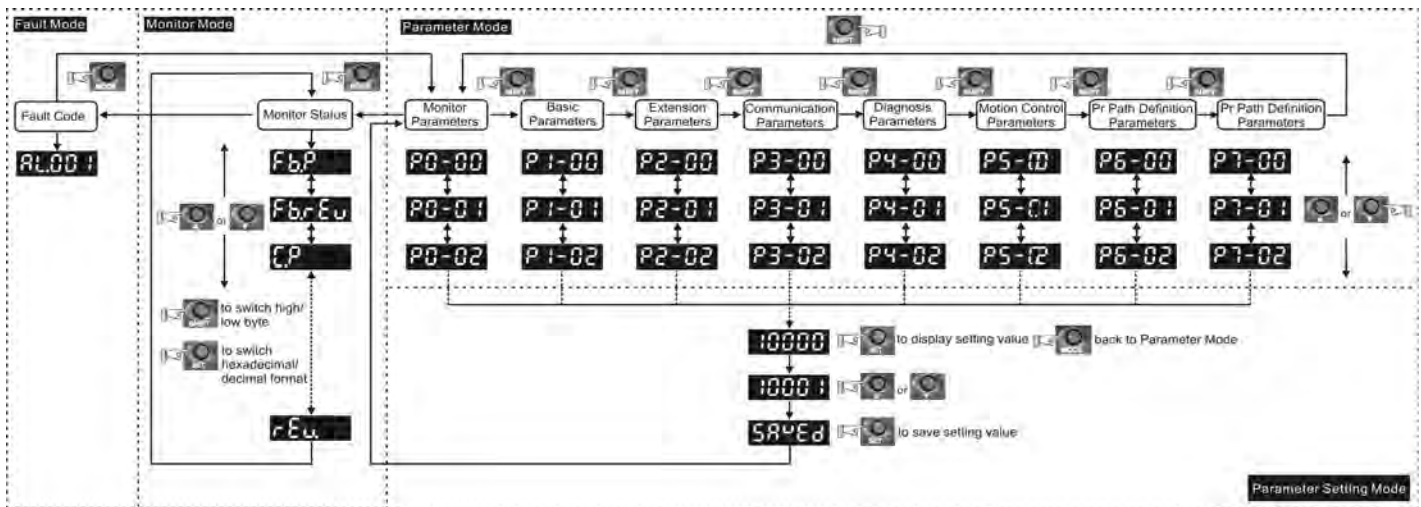
Figure 4.1 Keypad Features



Name	Function
LCD Display	The LCD Display (5-digit, 7-step display panel) shows the monitor codes, parameter settings and operation values of the AC servo drive.
Charge LED	The Charge LED lights to indicate the power is applied to the circuit.
MODE Key	MODE Key. Pressing MODE key can enter or exit different parameter groups, and switch between Monitor mode and Parameter mode.
SHIFT Key	SHIFT Key. Pressing SHIFT key can scrolls through parameter groups. After a parameter is selected and its value displayed, pressing SHIFT key can move the cursor to the left and then change parameter settings (blinking digits) by using arrow keys.
UP and DOWN Key	UP and DOWN Key. Pressing the UP and DOWN key can scroll through and change monitor codes, parameter groups and various parameter settings.
SET Key	SET Key. Pressing the SET key can display and save the parameter groups, the various parameter settings. In monitor mode, pressing SET key can switch decimal or hexadecimal display. In parameter mode, pressing SET key can enter into parameter setting mode. During diagnosis operation, pressing SET key can execute the function in the last step. (The parameter settings changes are not effective until the SET key is pressed.)

4.2 Display Flowchart

Figure 4.2 Keypad Operation









1. When the power is applied to the AC servo drive, the LCD display will show the monitor function codes for approximately one second, then enter into the monitor mode.
2. In monitor mode, pressing MODE key can enter into parameter mode. In parameter mode, pressing MODE key can return to monitor mode.
3. No matter working in which mode, when an alarm occurs, the system will enter into fault mode immediately. In fault mode, pressing MODE key can switch to other modes. In other modes, if no key is pressed for over 20 seconds, the system will return to fault mode automatically.
4. In monitor mode, pressing UP or DOWN arrow key can switch monitor parameter code. At this time, monitor display symbol will display for approximately one second.
5. In monitor mode, pressing MODE key can enter into parameter mode. In parameter mode, pressing SHIFT key can switch parameter group and pressing UP or DOWN arrow key can change parameter group code.
6. In parameter mode, the system will enter into the setting mode immediately after the Set key is pressed. The LCD display will display the corresponding setting value of this parameter simultaneously. Then, users can use UP or DOWN arrow key to change parameter value or press MODE key to exit and return back to the parameter mode.
7. In parameter setting mode, the users can move the cursor to left by pressing SHIFT key and change the parameter settings (blinking digits) by pressing the UP or DOWN arrow key.
8. After the setting value change is completed, press SET key to save parameter settings or execute command.
9. When the parameter setting is completed, LCD display will show the end code "SAVED" and automatically return back to parameter mode.


4.3 Status Display

4.3.1 Save Setting Display


After the SET key is pressed, LCD display will show the following display messages for approx. one second according to different status.

Display Message	Description
	The setting value is saved correctly. [Saved)
	This parameter is read only. Write-protected. (Read-Only)
	Invalid password or no password was input. (Locked)
	The setting value is error or invalid. (Out of Range)
	The servo system is running and it is unable to accept this setting value to be changed. (Servo On)
	This parameter is valid after restarting the drive. (Power On)


4.3.2 Decimal Point Display


Display Message	Description
	High/Low byte display. When the data is a decimal 32-bit data, these two digits are used to show if the display is high byte or low byte. Negative value display. When the data is displayed in decimal format, the most left two digits represent negative sign no matter it is a 16-bit or 32-bit data. If the data is displayed in hexadecimal format, it is a positive value always and no negative sign is displayed.

4.3.3 Fault Message Display

Display Message	Description
	When the AC servo drive has a fault, LCD display will display "ALnnn". "AL" indicates the alarm and "nnn" indicates the drive fault code. For the list of drive fault code, please refer to parameter P0-01 in Chapter 8 (Servo Parameters) or refer to Chapter 11 (Troubleshooting).











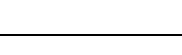
4.3.4 Polarity Setting Display








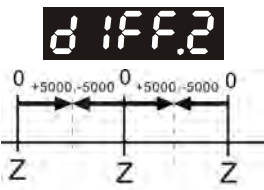






Display Message	Description
	Positive value display. When entering into parameter setting mode, pressing UP or DOWN arrow key can increase or decrease the display value. SHIFT key is used to change the selected digit (The selected digit will blink).



Display Message	Description
	Negative value display. Continuously press SHIFT key for two seconds and then the positive(+) or negative(-) sign can be switched. When the setting value exceeds its setting range, the positive(+) and negative(-) sign can not be switched. (The negative value display is for a decimal negative value only. There is no negative value display for a hexadecimal negative value.)

4.3.5 Monitor Setting Display








When the AC servo drive is applied to power, the LCD display will show the monitor function codes for approximately one second and then enter into the monitor mode. In monitor mode, in order to change the monitor status, the users can press UP or DOWN arrow key or change parameter P0-02 directly to specify the monitor status. When the power is applied, the monitor status depends on the setting value of P0-02. For example, if the setting value of P0-02 is 4 when the power is applied, the monitor function will be input pulse number of pulse command, the C-PLS monitor codes will first display and then the pulse number will display after.

P0-02 Setting	Display Message	Description	Unit
0		Motor feedback pulse number (after electronic gear ratio is set)	[user unit]
1		Input pulse number of pulse command (after electronic gear ratio is set)	[user unit]
2		Position error counts between control command pulse and feedback pulse	[user unit]
3		Motor feedback pulse number (encoder unit, 1280000 pulse/rev)	[pulse]
4		Input pulse number of pulse command (before electronic gear ratio is set)	[pulse]
5		Position error counts	[pulse]
6		Input frequency of pulse command	[Kpps]
7		Motor rotation speed	[r/min]
8		Speed input command	[Volt]
9		Speed input command	[r/min]
10		Torque input command	[Volt]

P0-02 Setting	Display Message	Description	Unit
11		Torque input command	[%]
12		Average load	[%]
13		Peak load	[%]
14		Main circuit voltage	[Volt]
15		Ratio of load inertia to Motor inertia (Please note that if the display is 130, it indicates that the actual inertia is 13.0)	[0.1 times]
16		IGBT temperature	[°C]
17		Resonance frequency (The low byte is the first resonance point and the high byte is the second resonance point.)	[Hz]
18		Absolute pulse number relative to encoder (use Z phase as home). The value of Z phase home point is 0, and it can be the value from -5000 to +5000 pulses.	-
19		Mapping Parameter 1: Display the content of parameter P0-25 (mapping target is specified by parameter P0-35)	-
20		Mapping Parameter 2: Display the content of parameter P0-26 (mapping target is specified by parameter P0-36)	-
21		Mapping Parameter 3: Display the content of parameter P0-27 (mapping target is specified by parameter P0-37)	-
22		Mapping Parameter 4: Display the content of parameter P0-28 (mapping target is specified by parameter P0-38)	-
23		Status Monitor 1: Display the content of parameter P0-09 (the monitor status is specified by parameter P0-17)	-
24		Status Monitor 2: Display the content of parameter P0-10 (the monitor status is specified by parameter P0-18)	-

P0-02 Setting	Display Message	Description	Unit
25		Status Monitor 3: Display the content of parameter P0-11 (the monitor status is specified by parameter P0-19)	-
26		Status Monitor 4: Display the content of parameter P0-12 (the monitor status is specified by parameter P0-20)	-

The following table lists the display examples of monitor value:

Display Message	Description	
 (Dec.)	16-bit Data	Decimal display. When the actual value is 1234, the display is 01234.
 (Hex.)		Hexadecimal display. When the actual value is 0x1234, the display is 1234.
 (Dec. High Byte)  (Dec. Low Byte)	32-bit Data	Decimal display. When the actual value is 1234567890, the display of high byte is 1234.5 and the display of low byte is 67890.
 (Hex. High Byte)  (Hex. Low Byte)		Hexadecimal display. When the actual value is 0x12345678, the display of high byte is h1234 and the display of low byte is L5678.
	Negative value display. When the actual value is -12345, the display is 1.2.3.4.5. (The negative value display is displayed to indicate a decimal negative value. There is no negative value display for a hexadecimal negative value.)	

NOTE

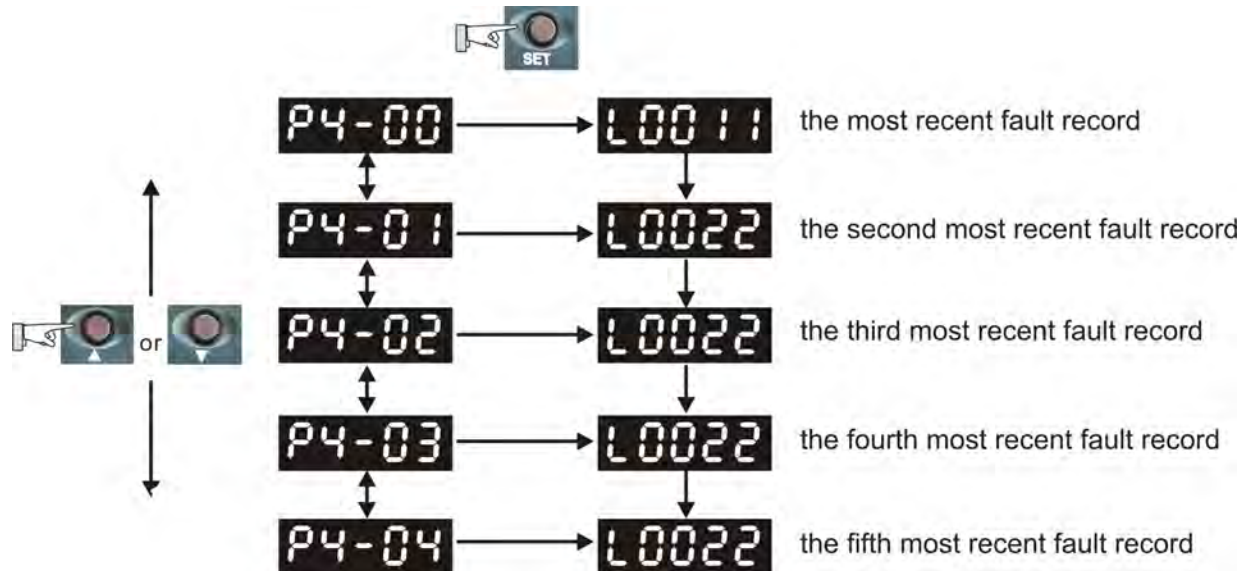
- 1) Dec. represents Decimal display and Hex. represents Hexadecimal display.
- 2) The above display methods are both available in monitor mode and parameter setting mode.
- 3) All monitor variables are 32-bit data. The users can switch to high byte or low byte and display format (Dec. or Hex.) freely. Regarding the parameters listed in Chapter 8, for each parameter, only one kind of display format is available and cannot be changed.

4.4 General Function Operation

4.4.1 Fault Code Display Operation

After entering the parameter mode P4-00 to P4-04 (Fault Record), press SET key to display the corresponding fault code history for the parameter. Please refer to the Figure 4.3.

Figure 4.3



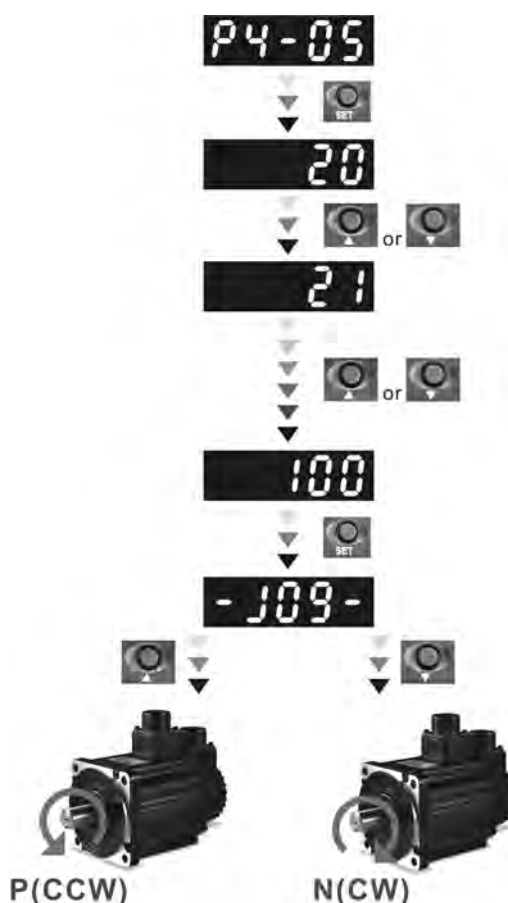
4.4.2 JOG Operation

After entering parameter mode P4-05, the users can follow the following steps to perform JOG operation. (Please also refer to Figure 4.4).

- Step1. Press the SET key to display the JOG r/min speed. (The default value is 20 r/min).
- Step2. Press the UP or DOWN arrow keys to increase or decrease the desired JOG speed. (This also can be undertaken by using the SHIFT key to move the cursor to the desired unit column (the effected number will blink) then changed using the UP and DOWN arrow keys. The example display in Figure 4.4 is adjusted as 100 r/min.)
- Step3. Press the SET key when the desired JOG speed is set. The Servo Drive will display "JOG".
- Step4. Press the UP or DOWN arrow keys to jog the motor either N(CW) and P(CCW) direction. The motor will only rotate while the arrow key is activated.
- Step5. To change JOG speed again, press the MODE key. The servo Drive will display "P4 - 05". Press the SET key and the JOG r/min speed will displayed again. Refer back to #2 and #3 to change speed.

NOTE

- 1) JOG operation is effective only when Servo On (when the servo drive is enabled).

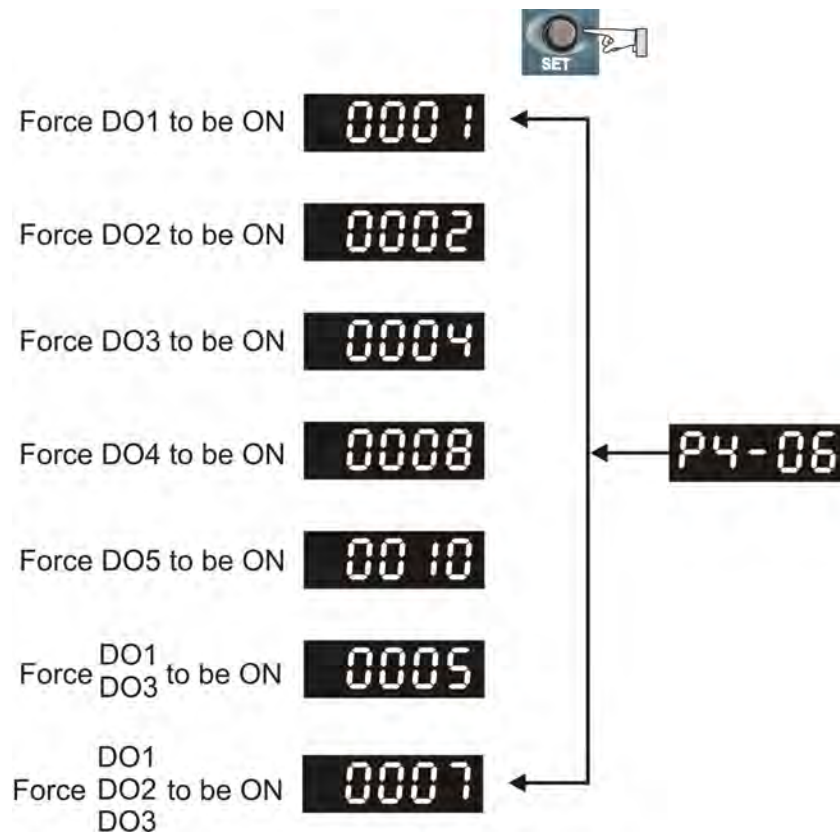
Figure 4.4

4.4.3 Force Output Control Operation

For testing, the digital outputs can be forced to be activated (ON) or inactivated (OFF) by using parameter P2-08 and P4-06. First, set P2-08 to 406 to enable the force output control function and then using P4-06 to force the digital outputs to be activated. Follow the setting method in Figure 4.6 to enter into Force Output Control operation mode. When P4-06 is set to 2, the digital output, DO2 is activated. When P4-06 is set to 5, the digital outputs, DO1 and DO3 are both activated. The parameter setting value of P4-06 is not retained when power is off. After re-power the servo drive, all digital outputs will return to the normal status. If P2-08 is set to 400, it also can switch the Force Output Control operation mode to normal Digital Output (DO) Control operation mode.

1The DO function and status is determined by P2-18 to P2-22. This function is enabled only when Servo Off (the servo drive is disabled).

Figure 4.6


 **NOTE**

1) As the display of P4-06 is hexadecimal, 0(zero) of the fifth digit will not show on the LED display.

4.4.4 DI Diagnosis Operation

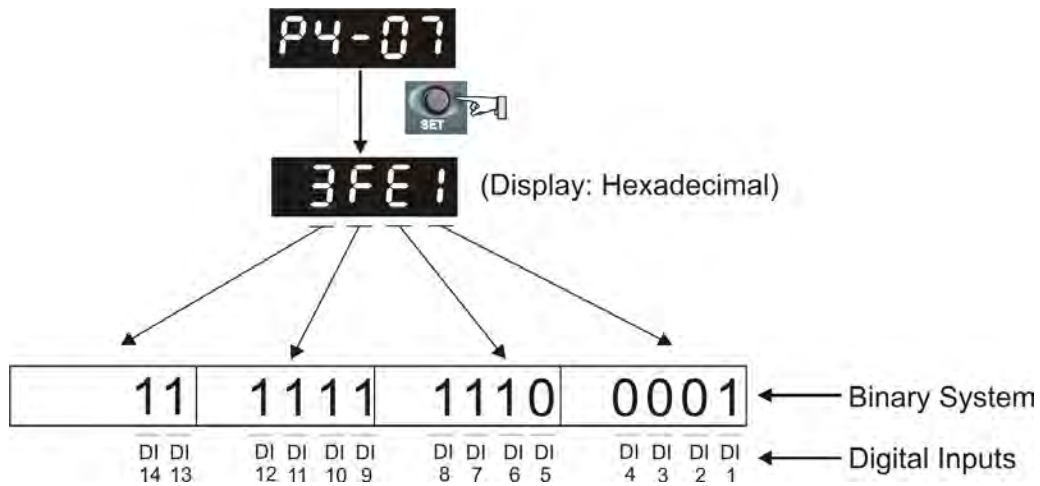
Following the setting method in Figure 4.7 can perform DI diagnosis operation (parameter P4-07, Input Status). According to the ON and OFF status of the digital inputs DI1 to DI8, the corresponding status will display on the servo drive LED display. When the Bit is set to “1”, it means that the corresponding digital input signal is ON. (Please also refer to Figure 4.7)

For example:

Suppose that the servo drive LED display is “3FE1”.

“E” is hexadecimal, which is equal to “1110” in binary system, and it means that the digital inputs DI6 ~ DI8 are ON.

Figure 4.7



4.4.5 DO Diagnosis Operation

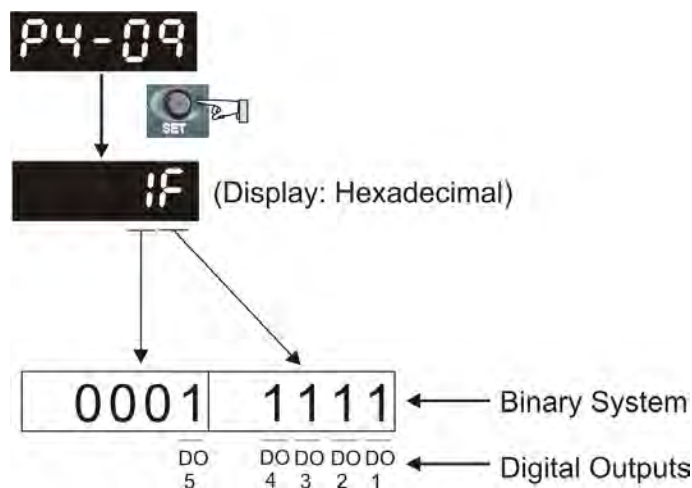
Following the setting method in Figure 4.8 can perform DO diagnosis operation (parameter P4-09, Output Status Display). According to the ON and OFF status of the digital outputs DO1 to DO5, the corresponding status will display on the servo drive LED display. When the Bit is set to “1”, it means that the corresponding digital output signal is ON. (Please also refer to Figure 4.8)

For example:

Suppose that the servo drive LED display is “1F”.

“F” is hexadecimal, which is equal to “1111” in binary system, and it means that the digital outputs DO1 ~ DO4 are ON.

Figure 4.8



Chapter 5 Trial Run and Tuning Procedure

This chapter, which is divided into two parts, describes trial run for servo drive and motor. One part is to introduce the trial run without load, and the other part is to introduce trial run with load. Ensure to complete the trial run without load first before performing the trial run with load.

5.1 Inspection without Load

In order to prevent accidents and avoid damaging the servo drive and mechanical system, the trial run should be performed under no load condition (no load connected, including disconnecting all couplings and belts). Do not run servo motor while it is connected to load or mechanical system because the unassembled parts on motor shaft may easily disassemble during running and it may damage mechanical system or even result in personnel injury. After removing the load or mechanical system from the servo motor, if the servo motor can run normally following up the normal operation procedure (when trial run without load is completed), then the users can connect to the load and mechanical system to run the servo motor.



- *In order to prevent accidents, the initial trial run for servo motor should be conducted under no load conditions (separate the motor from its couplings and belts).*
- *Caution: Please perform trial run without load first and then perform trial run with load connected. After the servo motor is running normally and regularly without load, then run servo motor with load connected. Ensure to perform trial run in this order to prevent unnecessary danger.*

After power is connected to AC servo drive, the charge LED will light and it indicates that AC servo drive is ready. Please check the followings before trial run:

1. Inspection before operation (Control power is not applied)
 - Inspect the servo drive and servo motor to insure they were not damaged.
 - Ensure that all wiring terminals are correctly insulated.
 - Ensure that all wiring is correct or damage and or malfunction may result.
 - Visually check to ensure that there are not any unused screws, metal strips, or any conductive or inflammable materials inside the drive.
 - Make sure control switch is OFF.
 - Never put inflammable objects on servo drive or close to the external regenerative resistor.
 - If the electromagnetic brake is being used, ensure that it is correctly wired.
 - If required, use an appropriate electrical filter to eliminate noise to the servo drive.

- Ensure that the external applied voltage to the drive is correct and matched to the controller.
2. Inspection during operation (Control power is applied)
- Ensure that the cables are not damaged, stressed excessively or loaded heavily. When the motor is running, pay close attention on the connection of the cables and notice that if they are damaged, frayed or over extended.
 - Check for abnormal vibrations and sounds during operation. If the servo motor is vibrating or there are unusual noises while the motor is running, please contact the dealer or manufacturer for assistance.
 - Ensure that all user-defined parameters are set correctly. Since the characteristics of different machinery equipment are not the same, in order to avoid accident or cause damage, do not adjust the parameter abnormally and ensure the parameter setting is not an excessive value.
 - Ensure to reset some parameters when the servo drive is off (Please refer to Chapter 8). Otherwise, it may result in malfunction.
 - If there is no contact sound or there be any unusual noises when the relay of the servo drive is operating, please contact your distributor for assistance or contact with Delta.
 - Check for abnormal conditions of the power indicators and LED display. If there is any abnormal condition of the power indicators and LED display, please contact your distributor for assistance or contact with Delta.

5.2 Applying Power to the Drive

The users please observe the following steps when applying power supply to the servo drive.

1. Please check and confirm the wiring connection between the drive and motor is correct.
 - 1) Terminal U, V, W and FG (frame ground) must connect to Red, White, Black and Green cables separately (U: Red, V: White, W: Black, FG: Green). If not connect to the specified cable and terminal, then the drive cannot control motor. The motor grounding lead, FG must connect to grounding terminal. For more information of cables, please refer to section 3.1.
 - 2) Ensure to connect encoder cable to CN2 connector correctly. If the users only desire to execute JOG operation, it is not necessary to make any connection to CN1 and CN3 connector. For more information of the connection of CN2 connector, please refer to Section 3.1 and 3.4.



➤ ***Do not connect the AC input power (R, S, T) to the (U, V, W) output terminals. This will damage the AC servo drive.***

2. Main circuit wiring

Connect power to the AC servo. For three-phase input power connection and single-phase input power connection, please refer to Section 3.1.3.

3. Turn the Power On

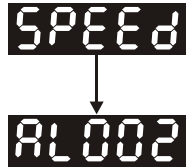
The Power includes control circuit power (L1c, L2c) and main circuit power (R, S, T). When the power is on, the normal display should be shown as the following figure:

As the default settings of digital input signal, DI6, DI7 and DI8 are Reverse Inhibit Limit (NL), Forward Inhibit Limit (PL) and Emergency Stop (EMGS) respectively, if the users do not want to use the default settings of DI6 ~ DI8, the users can change their settings by using parameters P2-15 to P2-17 freely. When the setting value of parameters P2-15 to P2-17 is 0, it indicates the function of this DI signal is disabled. For more information of parameters P2-15 to P2-17, please refer to Chapter 8 "Parameters".

If the parameter P0-02 is set as motor speed (06), the normal display should be shown as the following figure:

If there is no text or character displayed on the LED display, please check if the voltage of the control circuit terminal ((L1c, L2c) is over low.

1) When display shows:



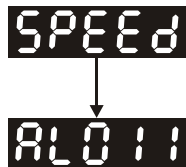
Overvoltage:

The main circuit voltage has exceeded its maximum allowable value or input power is error (Incorrect power input).

Corrective Actions:

- Use voltmeter to check whether the main circuit input voltage falls within the rated input voltage.
- Use voltmeter to check whether the input voltage is within the specified limit.

2) When display shows:



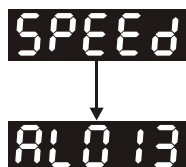
Encoder error:

Check if the wiring is correct. Check if the encoder wiring (CN2) of servo motor is loose or incorrect.

Corrective Actions:

- Check if the users perform wiring recommended in the user manual.
- Examine the encoder connector and cable.
- Inspect whether wire is loose or not.
- Check if the encoder is damaged.

3) When display shows:



Emergency stop activated:

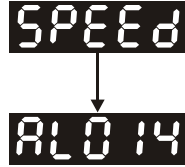
Please check if any of digital inputs DI1 ~ DI8 signal is set to “Emergency Stop” (EMGS).

Corrective Actions:

- If it does not need to use “Emergency Stop (EMGS)” as input signal, the users only need to confirm that if all of the digital inputs DI1 ~ DI8 are not set to “Emergency Stop (EMGS)”. (The setting value of parameter P2-10 to P2-17 is not set to 21.)

- If it is necessary to use “Emergency Stop (EMGS)” as input signal, the users only need to confirm that which of digital inputs DI1 ~ DI8 is set to “Emergency Stop (EMGS)” and check if the digital input signal is ON (It should be activated).

4) When display shows:



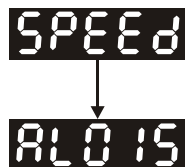
Reverse limit switch error:

Please check if any of digital inputs DI1 ~ DI8 signal is set to “Reverse inhibit limit (NL)” and check if the signal is ON or not.

Corrective Actions:

- If it does not need to use “Reverse inhibit limit (NL)” as input signal, the users only need to confirm that if all of the digital inputs DI1 ~ DI8 are not set to “Reverse inhibit limit (NL)”. (The setting value of parameter P2-10 to P2-17 is not set to 22.)
- If it is necessary to use “Reverse inhibit limit (NL)” as input signal, the users only need to confirm that which of digital inputs DI1 ~ DI8 is set to “Reverse inhibit limit (NL)” and check if the digital input signal is ON (It should be activated).

5) When display shows:



Forward limit switch error:

Please check if any of digital inputs DI1 ~ DI8 signal is set to “Forward inhibit limit (PL)” and check if the signal is ON or not.

Corrective Actions:

- If it is no need to use “Forward inhibit limit (PL)” as input signal, the users only need to confirm that if all of the digital inputs DI1 ~ DI8 are not set to “Forward inhibit limit (PL)”. (The setting value of parameter P2-10 to P2-17 is not set to 23.)
- If it is necessary to use “Forward inhibit limit (PL)” as input signal, the users only need to confirm that which of digital inputs DI1 ~ DI8 is set to “Forward inhibit limit (PL)” and check if the digital input signal is ON (It should be activated).

When “Digital Input 1 (DI1)” is set to Servo On (SON), if DI1 is set to ON (it indicates that Servo On (SON) function is enabled) and the following fault message shows on the display:

6) When display shows:

A digital display showing the fault code AL001 in a black box.

Overcurrent:

Corrective Actions:

- Check the wiring connections between the servo drive and motor.
- Check if the circuit of the wiring is closed.
- Remove the short-circuited condition and avoid metal conductor being exposed.

7) When display shows:

A digital display showing the fault code AL003 in a black box.

Undervoltage:

Corrective Actions:

- Check whether the wiring of main circuit input voltage is normal.
- Use voltmeter to check whether input voltage of main circuit is normal.
- Use voltmeter to check whether the input voltage is within the specified limit.

 **NOTE**

- 1) If there are any unknown fault codes and abnormal display when applying power to the drive or servo on is activated (without giving any command), please inform the distributor or contact with Delta for assistance.

5.3 JOG Trial Run without Load

It is very convenient to use JOG trial run without load to test the servo drive and motor as it can save the wiring. The external wiring is not necessary and the users only need to connect the digital keypad to the servo drive. For safety, it is recommended to set JOG speed at low speed. Please refer to the following steps to perform JOG trial run without load.

STEP 1: Turn the drive ON through software. Ensure that the setting value of parameter P2-30 should be set to 1 (Servo On).

STEP 2: Set parameter P4-05 as JOG speed (unit: r/min). After the desired JOG speed is set, and then press SET key, the drive will enter into JOG operation mode automatically

STEP 3: The users can press UP and DOWN key to change JOG speed and press SHIFT key to adjust the digit number of the displayed value.

STEP 4: Pressing SET key can determine the speed of JOG operation.

STEP 5: Pressing UP key and the servo motor will run in P(CCW) direction. After releasing UP key, the motor will stop running.

STEP 6: Pressing DOWN key and the servo motor will run in N(CW) direction. After releasing DOWN key, the motor will stop running.

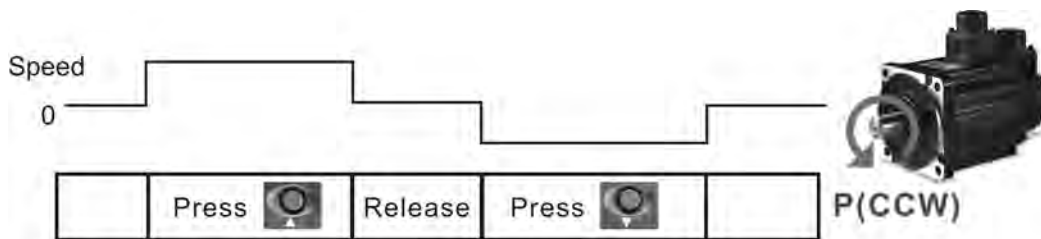
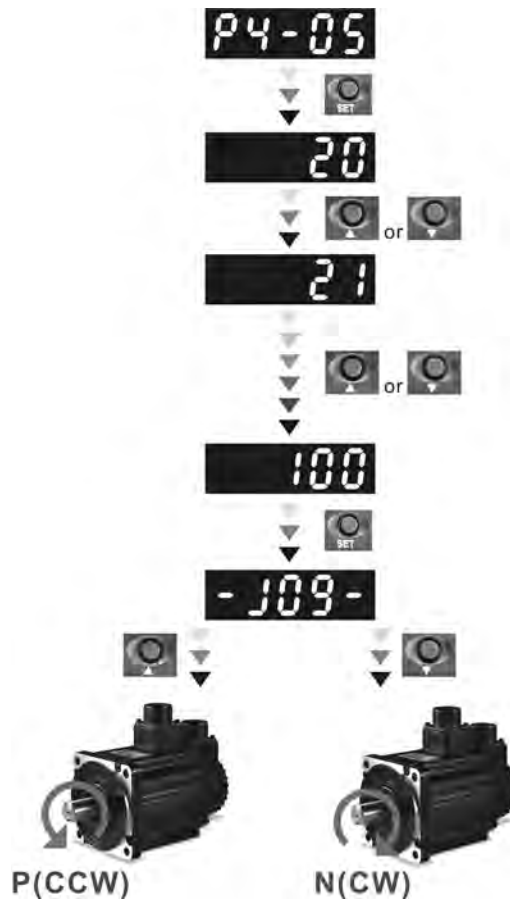
N(CW) and P(CCW) Definition:

P(CCW, Counterclockwise): when facing the servo motor shaft, P is running in counterclockwise direction.

N(CW, Clockwise): when facing the servo motor shaft, N is running in clockwise direction.

STEP 7: When pressing MODE key, it can exit JOG operation mode.

In the example below, the JOG speed is adjusted from 20r/min (Default setting) to 100r/min.



If the servo motor does not rotate, please check if the wiring of U, V, W terminals and encoder is correct or not.

If the servo motor does not rotate properly, please check if the phase of U, V, W cables is connected correctly.

5.4 Speed Trial Run without Load

Before speed trial run, fix and secure the motor as possible to avoid the danger from the reacting force when motor speed changes.

STEP 1:

Set the value of parameter P1-01 to 02 and it is speed (S) control mode. After selecting the operation mode as speed (S) control mode, please restart the drive as P1-01 is effective only after the servo drive is restarted (after switching power off and on).

STEP 2:

In speed control mode, the necessary Digital Inputs are listed as follows:

Digital Input	Parameter Setting Value	Sign	Function Description	CN1 PIN No.
DI1	P2-10=101	SON	Servo On	DI1=9
DI2	P2-11=109	TRQLM	Torque limit enabled	DI2=10
DI3	P2-12=114	SPD0	Speed command selection	DI3=34
DI4	P2-13=115	SPD1	Speed command selection	DI4=8
DI5	P2-14=102	ARST	Reset	DI5=33
DI6	P2-15=0	Disabled	This DI function is disabled	-
DI7	P2-16=0	Disabled	This DI function is disabled	-
DI8	P2-17=0	Disabled	This DI function is disabled	-
EDI9	P2-36=0	Disabled	This DI function is disabled	CN7=2
EDI10	P2-37=0	Disabled	This DI function is disabled	CN7=3
EDI11	P2-38=0	Disabled	This DI function is disabled	CN7=4
EDI12	P2-39=0	Disabled	This DI function is disabled	CN7=5
EDI13	P2-40=0	Disabled	This DI function is disabled	CN7=6
EDI14	P2-41=0	Disabled	This DI function is disabled	CN7=7

By default, DI6 is the function of reverse inhibit limit, DI7 is the function of forward inhibit limit and DI8 is the function of emergency stop (DI8), if the users do not set the setting value of parameters P2-15 to P2-17 and P2-36 to P2-41 to 0 (Disabled), the faults (AL013, 14 and 15) will occur (For the information of fault messages, please refer to Chapter 11). Therefore, if the users do not need to use these three digit inputs, please set the setting value of parameters P2-15 to P2-17 and P2-36 to P2-41 to 0 (Disabled) in advance.

All the digital inputs of Delta ASDA-A2 series are user-defined, and the users can set the DI signals freely. Ensure to refer to the definitions of DI signals before defining them (For the description of DI signals, please refer to Table 8.A in Chapter 8). If any alarm code displays after the setting is completed, the users can restart the drive or set DI5 to be activated to clear the fault. Please refer to section 5.2.

The speed command is selected by SPD0, SPD1. Please refer to the following table:

Speed Command No.	DI signal of CN1		Command Source	Content	Range
	SPD1	SPD0			
S1	0	0	External analog command	Voltage between V-REF and GND	-10V ~ +10V
S2	0	1	Internal parameter	P1-09	-60000 ~ 60000
S3	1	0		P1-10	-60000 ~ 60000
S4	1	1		P1-11	-60000 ~ 60000

0: indicates OFF (Normally Open); 1: indicates ON (Normally Closed)

The range of internal parameter is from -60000 to 60000.

Setting value of speed command = Setting range x unit (0.1 r/min).

For example:

If P1-09 is set to +30000, the setting value of speed command = +30000 x 0.1 r/min = +3000 r/min.

The settings of speed command:

P1-09 is set to +30000

P1-10 is set to +1000

P1-11 is set to -30000

Input value command	Rotation direction
+	N(CW)
-	P(CCW)

STEP 3:

1. The users can use DI1 to enable the servo drive (Servo On).
2. If DI3 (SPD0) and DI4 (SPD1) are OFF both, it indicates S1 command is selected. At this time, the motor is operating according to external analog command.
3. If only DI3 is ON (SPD0), it indicates S2 command (P1-09 is set to +30000) is selected, and the motor speed is 3000r/min at this time.
4. If only DI4 is ON (SPD1), it indicates S3 command (P1-10 is set to +1000) is selected, and the motor speed is 100r/min at this time.
5. If DI3 (SPD0) and DI4 (SPD1) are ON both, it indicates S4 command (P1-11 is set to -30000) is selected, and the motor speed is -3000r/min at this time.
6. Repeat the action of (3), (4), (5) freely.
7. When the users want to stop the speed trial run, use DI1 to disable the servo drive (Servo Off).

5.5 Position Trial Run without Load

Before position trial run, fix and secure the motor as possible to avoid the danger from the reacting force when the motor speed changes.

STEP 1:

Set the value of parameter P1-01 to 01 and it is position (PR) control mode. After selecting the operation mode as position (PR) control mode, please restart the drive and the setting would be valid.

STEP 2:

In position control mode, the necessary DI setting is listed as follows:

Digital Input	Parameter Setting Value	Sign	Function Description	CN1 PIN No.
D11	P2-10=101	SON	Servo On	D11-=9
D12	P2-11=108	CTRG	Command triggered	D12-=10
D13	P2-12=111	POS0	Position command selection	D13-=34
D14	P2-13=112	POS1	Position command selection	D14-=8
D15	P2-14=102	ARST	Reset	D15-=33
D16	P2-15=0	Disabled	This DI function is disabled	-
D17	P2-16=0	Disabled	This DI function is disabled	-
D18	P2-17=0	Disabled	This DI function is disabled	-
EDI9	P2-36=0	Disabled	This DI function is disabled	CN7=2
EDI10	P2-37=0	Disabled	This DI function is disabled	CN7=3
EDI11	P2-38=0	Disabled	This DI function is disabled	CN7=4
EDI12	P2-39=0	Disabled	This DI function is disabled	CN7=5
EDI13	P2-40=0	Disabled	This DI function is disabled	CN7=6
EDI14	P2-41=0	Disabled	This DI function is disabled	CN7=7

By default, DI6 is the function of reverse inhibit limit, DI7 is the function of forward inhibit limit and DI8 is the function of emergency stop (DI8), if the users do not set the setting value of parameters P2-15 to P2-17 and P2-36 to P2-41 to 0 (Disabled), the faults (AL013, 14 and 15) will occur (For the information of fault messages, please refer to Chapter 11). Therefore, if the users do not need to use these three digit inputs, please set the setting value of parameters P2-15 to P2-17 and P2-36 to P2-41 to 0 (Disabled) in advance.

All the digital inputs of Delta ASDA-A2 series are user-defined, and the users can set the DI signals freely. Ensure to refer to the definitions of DI signals before defining them (For the description of DI signals, please refer to Table 8.A in Chapter 8). If any alarm code displays after the setting is completed, the users can restart the drive or set DI5 to be activated to clear the fault. Please refer to section 5.2. For the information of wiring diagrams, please refer to Section 3.10.2 (Wiring of position (PR) control mode). Because POS2 is not the default DI, the users need to change the value of parameter P2-14 to 113.

Please refer to the following table for 64 groups of position commands and position command selection from POS0 to POS5.

Position Command	POS5	POS4	POS3	POS2	POS1	POS0	CTRG	Parameters
P1	0	0	0	0	0	0	↑	P6-00
								P6-01
P2	0	0	0	0	0	1	↑	P6-02
								P6-03
~								~
P50	1	1	0	0	1	0	↑	P6-98
								P6-99
P51	1	1	0	0	1	1	↑	P7-00
								P7-01
~								~
P64	1	1	1	1	1	1	↑	P7-26
								P7-27

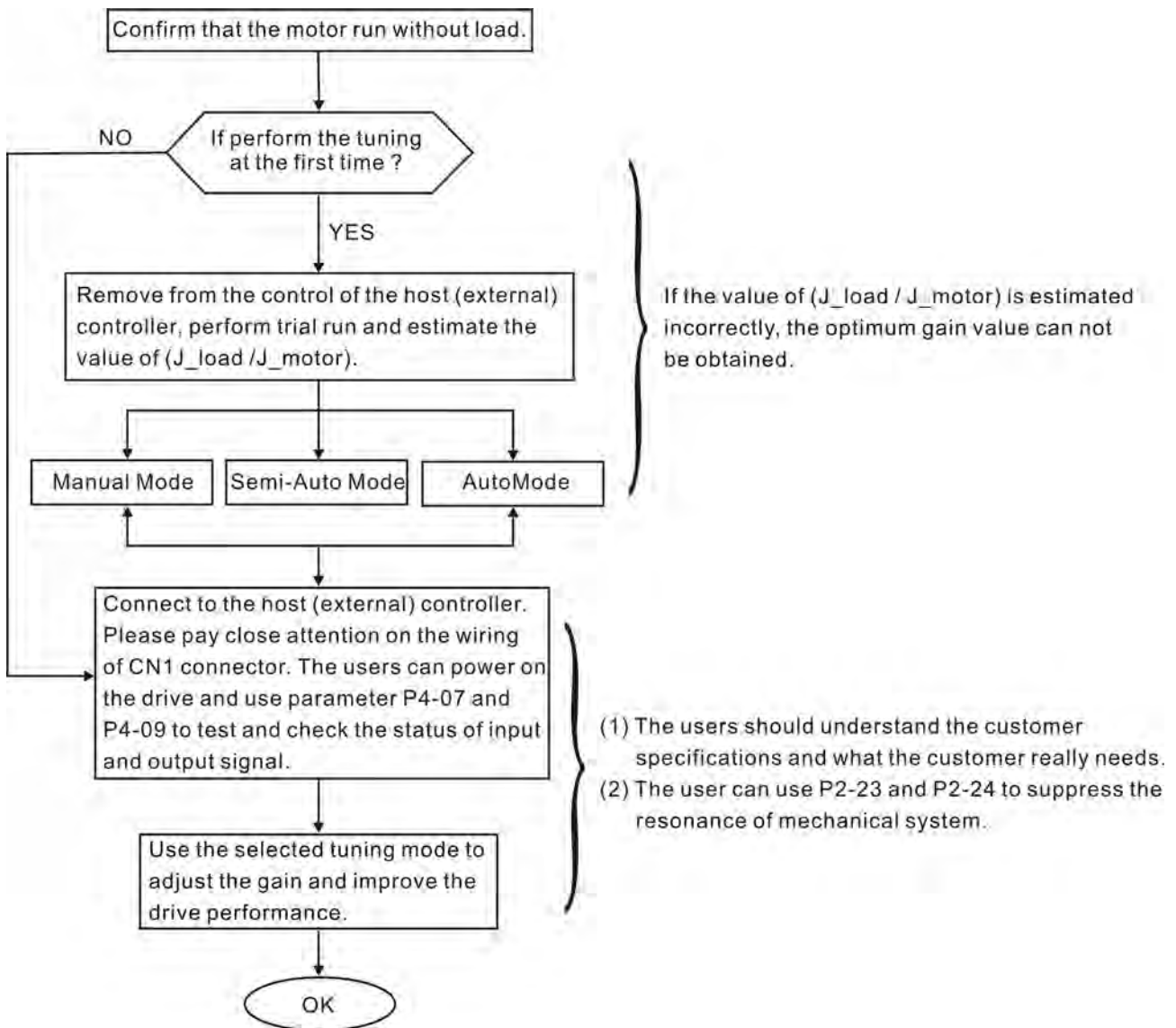
0: indicates OFF (Normally Open); 1: indicates ON (Normally Closed)

The users can set the value of these 64 groups of commands (P6-00 ~ P7-27) freely. The command can be absolute position command as well.

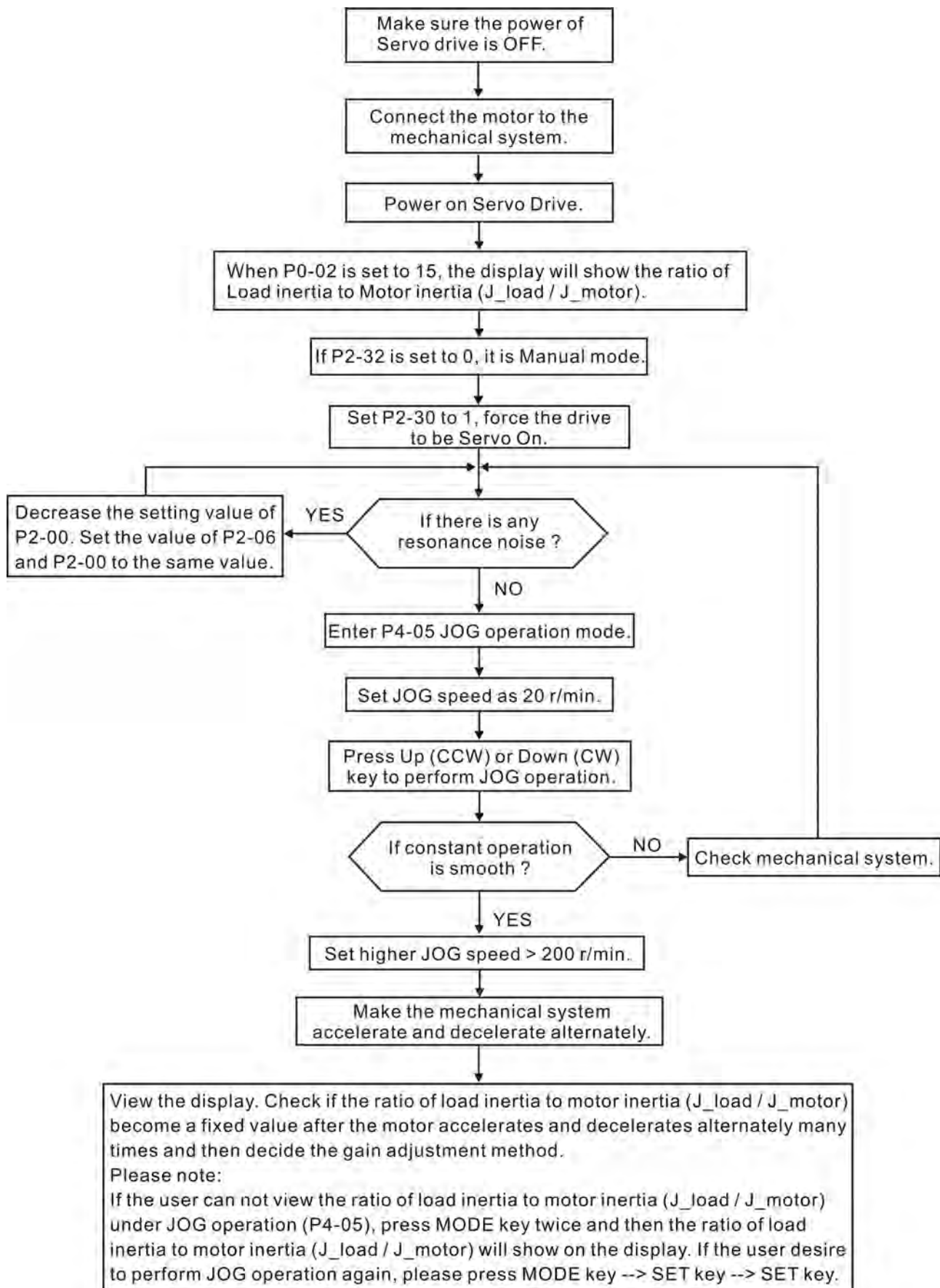
5.6 Tuning ProcedureTable 5.A Estimate the ratio of Load Inertia to Servo Motor Inertia (J_{load} / J_{motor}): JOG Mode

Tuning Procedure	Display
1. After wiring is completed, when power is connected to the AC servo drive, the right side display will show on the LCD display.	AL014
2. Press MODE key to enter into parameter mode.	P0-00
3. Press SHIFT key twice to select parameter group.	P2-00
4. Press UP key to view each parameter and select parameter P2-17.	P2-17
5. Press SET key to display the parameter value as shown on the right side.	21
6. Press SHIFT key twice to change the parameter values. Use UP key to cycle through the available settings and then press SET key to determine the parameter settings.	121
7. Press UP key to view each parameter and select parameter P2-30.	P2-30
8. Press SET key to display the parameter value as shown on the right side.	0
9. Select parameter value 1. Use UP key to cycle through the available settings.	1
10. At this time, the servo drive is ON and the right side display will appear next.	0
11. Press DOWN key three times to select the ratio of Load Inertia to Servo Motor Inertia (J_{load} / J_{motor}).	JL
12. Display the current ratio of Load Inertia to Servo Motor Inertia (J_{load} / J_{motor}). (5.0 is default setting.)	50
13. Press MODE key to select parameter mode.	P2-30
14. Press SHIFT key twice to select parameter group.	P4-00
15. Press UP key to select user parameter P4-05.	P4-05
16. Press SET key and JOG speed 20 r/min will be displayed. Press UP and DOWN key to increase and decrease JOG speed. To press SHIFT key one time can add one digit number.	20 ↓ 200
17. Select desired JOG speed, press SET key and it will show the right side display.	-J09-
18. Pressing UP key is forward rotation and pressing DOWN key is reverse rotation.	
19. Execute JOG operation in low speed first. After the machine is running smoothly, then execute JOG operation in high speed.	
20. The ratio of Load Inertia to Servo Motor Inertia (J_{load} / J_{motor}) cannot be shown in the display of JOG parameter P4-05 operation. Please press MODE key twice continuously and the users can see the ratio of Load Inertia to Servo Motor Inertia (J_{load} / J_{motor}). Then, execute JOG operation again, press MODE key once and press SET key twice to view the display on the keypad. Check if the value of J_{load} / J_{motor} is adjusted to a fixed value and displayed on the keypad after acceleration and deceleration repeatedly.	

5.6.1 Tuning Flowchart



5.6.2 Load Inertia Estimation Flowchart



5.6.3 Auto Mode Tuning Flowchart

Set P2-32 to 1 (1: Auto Mode [Continuous adjustment])

The servo drive will continuously estimate the system inertia, save the measured load inertia value automatically and memorized in P1-37 every 30 minutes by referring to the frequency response settings of P2-31.

P2-31 : Auto Mode Stiffness Setting (Default setting: 80)

In Auto mode and Semi-Auto mode, the speed loop frequency response settings are as follows:

1 ~ 50Hz : Low stiffness and low frequency response

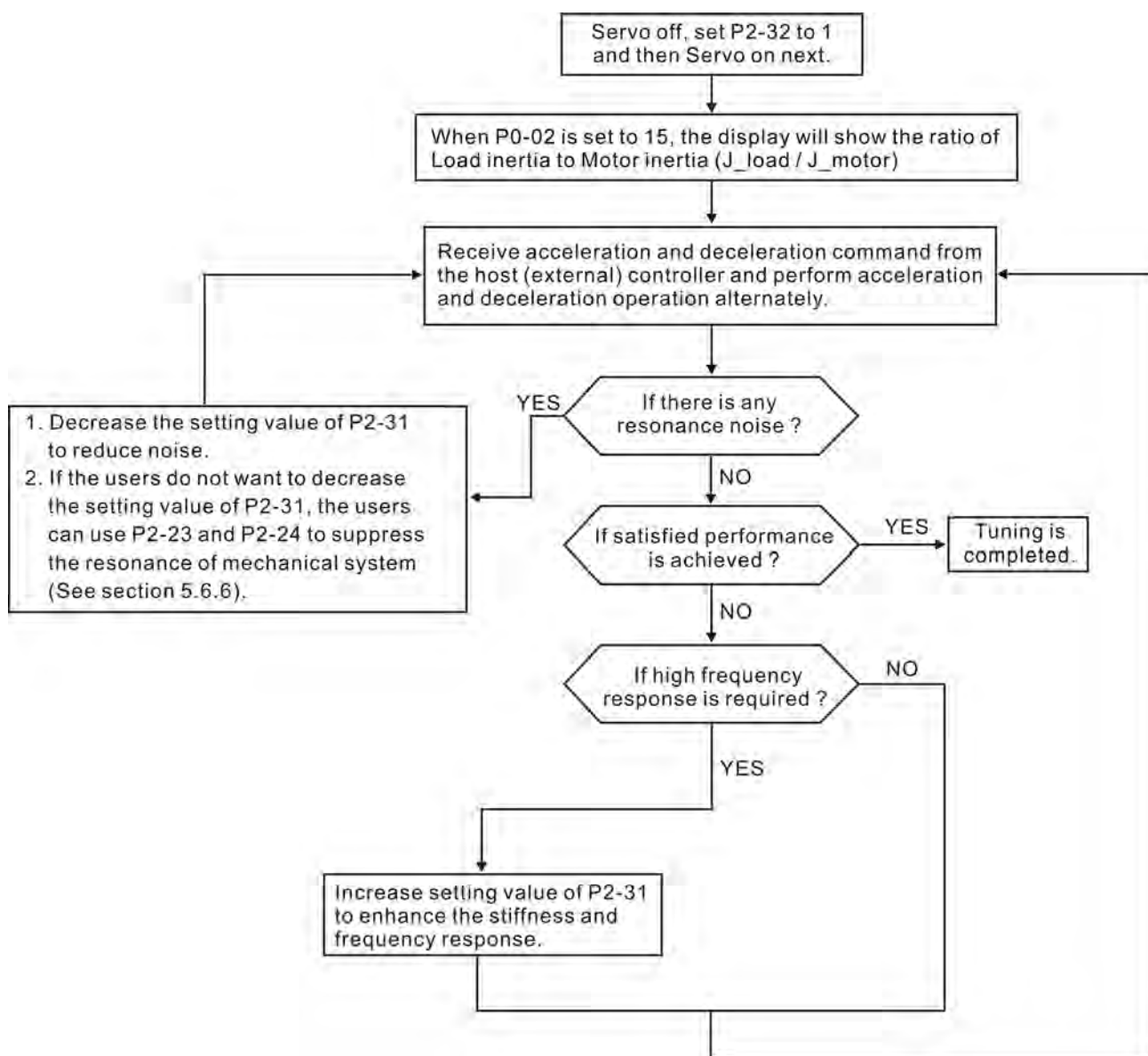
51 ~ 250Hz : Medium stiffness and medium frequency response

251 ~ 850Hz : High stiffness and high frequency response

851 ~ 1000Hz : Extremely high stiffness and extremely high frequency response

Adjust P2-31: Increase the setting value of P2-31 to enhance the stiffness or reduce the noise.

Continuously perform the adjustment until the satisfactory performance is achieved.



5.6.4 Semi-Auto Mode Tuning Flowchart

Set P2-32 to 2 (2: Semi-Auto Mode [Non-continuous adjustment])

The servo drive will continuously perform the adjustment for a period of time. After the system inertia becomes stable, it will stop estimating the system inertia, save the measured load inertia value automatically, and memorized in P1-37. When switching from other modes, such as Manual Mode or Auto Mode, to Semi-Auto Mode, the servo drive will perform continuous adjustment for estimating the load inertia (P1-37) again. The servo drive will refer to the frequency response settings of P2-31 when estimating the system inertia.

P2-31 : Auto Mode Stiffness Setting (Default setting: 80)

In Auto mode and Semi-Auto mode, the speed loop frequency response settings are as follows:

1 ~ 50Hz : Low stiffness and low frequency response

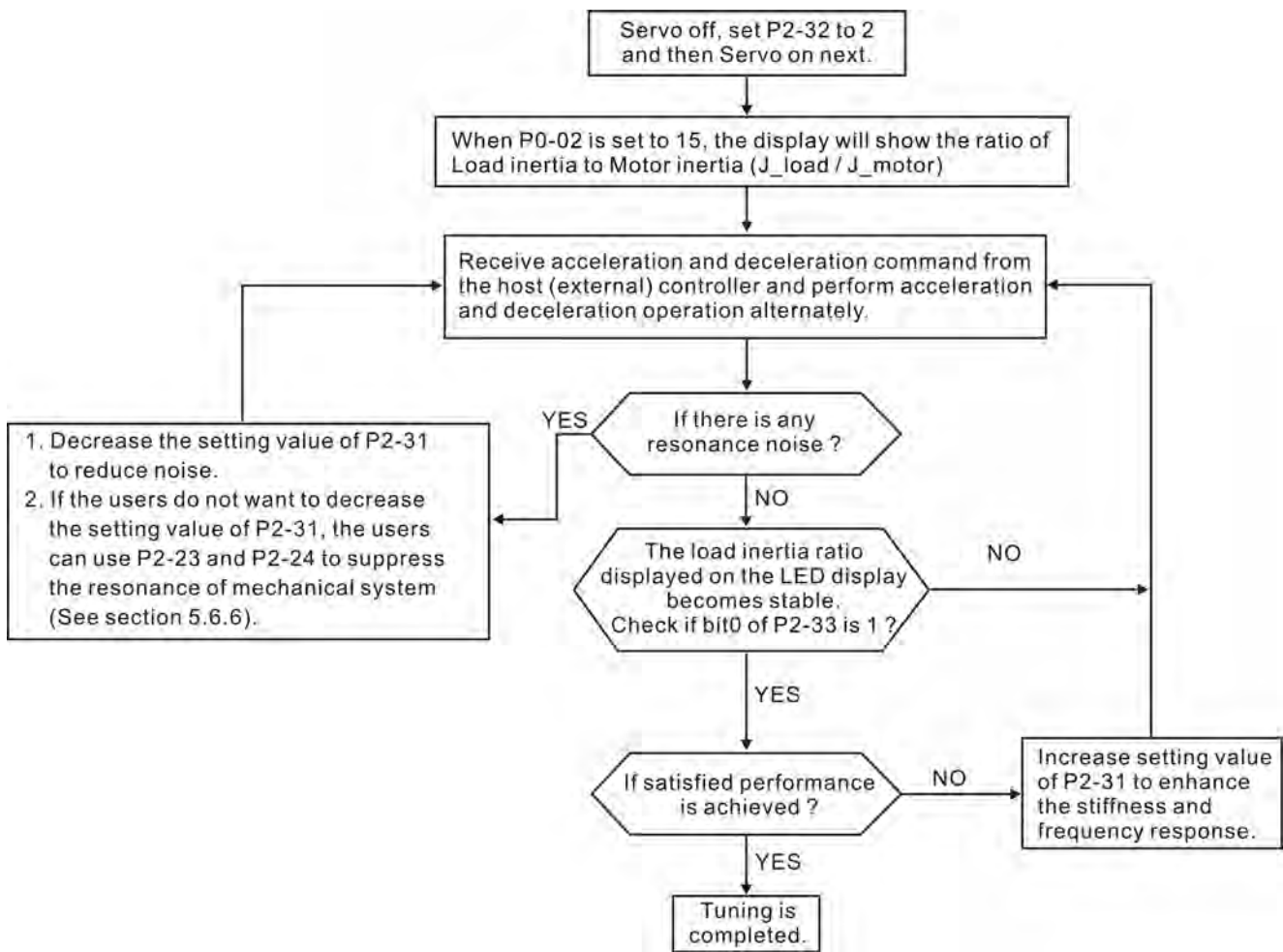
51 ~ 250Hz : Medium stiffness and medium frequency response

251 ~ 850Hz : High stiffness and high frequency response

851 ~ 1000Hz : Extremely high stiffness and extremely high frequency response

Adjust P2-31: Increase the setting value of P2-31 to enhance the frequency response or reduce the noise.

Continuously perform the adjustment until the satisfactory performance is achieved.

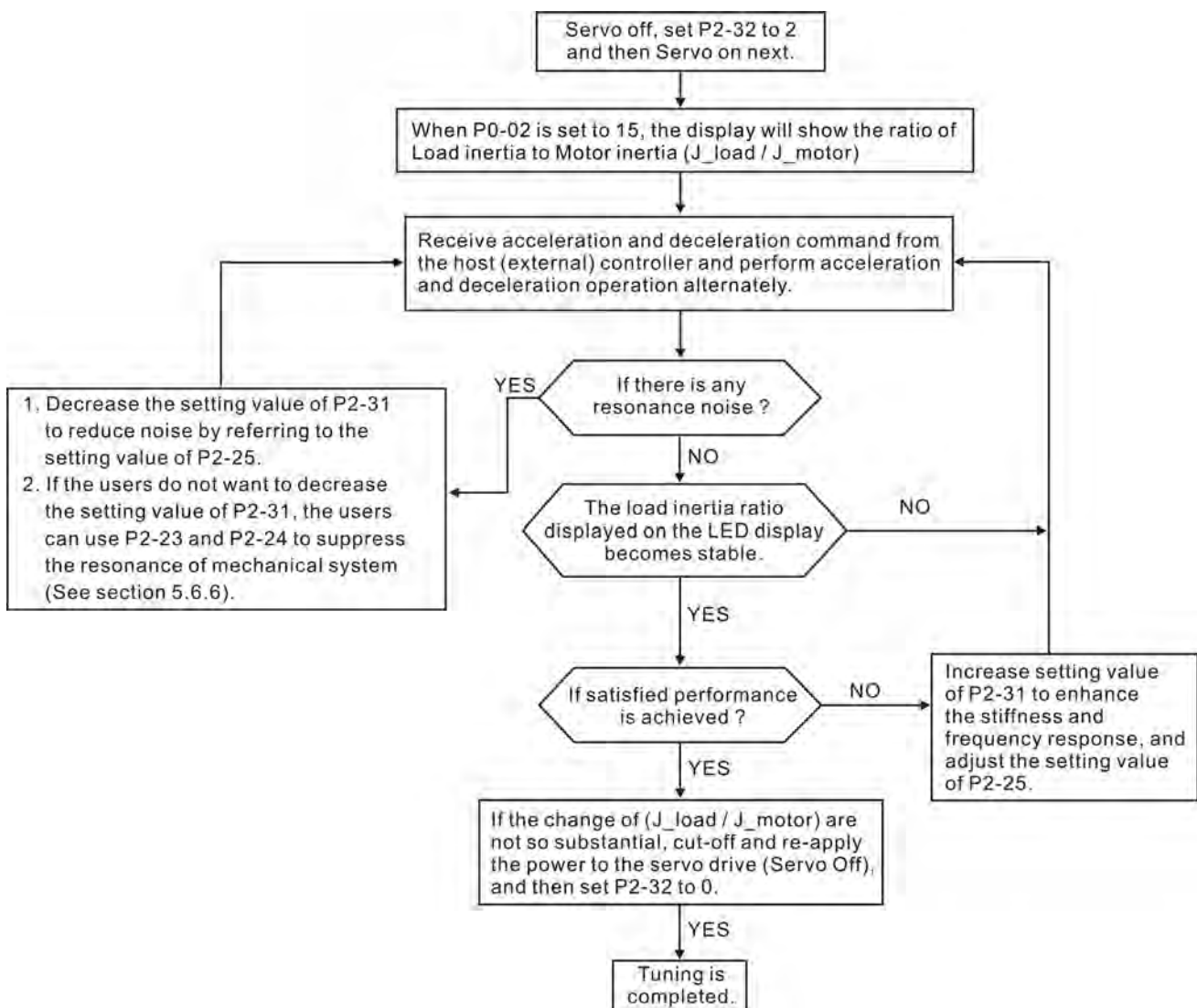


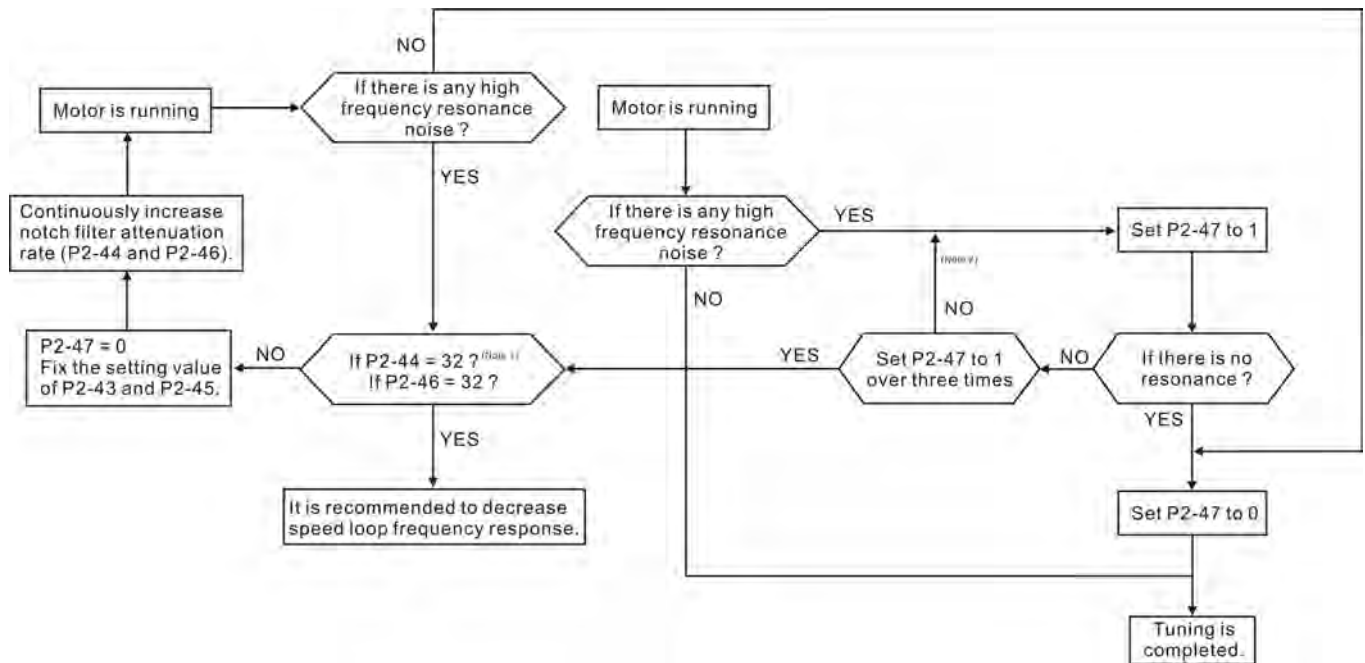
NOTE

- 1) When bit0 of P2-33 is set to 1, it indicates that the system inertia estimation of semi-auto mode has been completed and the measured load inertia value is saved and memorized in P1-37 automatically.
- 2) If reset bit0 of P2-33 to 0, it will start estimating the system inertia again.

5.6.5 Limit of Load Inertia Estimation

The accel. / decel. time for reaching 2000r/min must be below 1 second. The rotation speed must be above 200 r/min. The load inertia must be 100 multiple or less of motor inertia. The change of external force and the inertia ratio can not be too much. In Auto Mode (P2-32 is set to 1), the measured load inertia value will be saved automatically and memorized in P1-37 every 30 minutes. In Semi-Auto Mode, it will stop estimating the load inertia after a period of continuous adjustment time when the system inertia becomes stable. The measured load inertia value will be saved automatically and memorized in P1-37 when load inertia estimation is stopped.





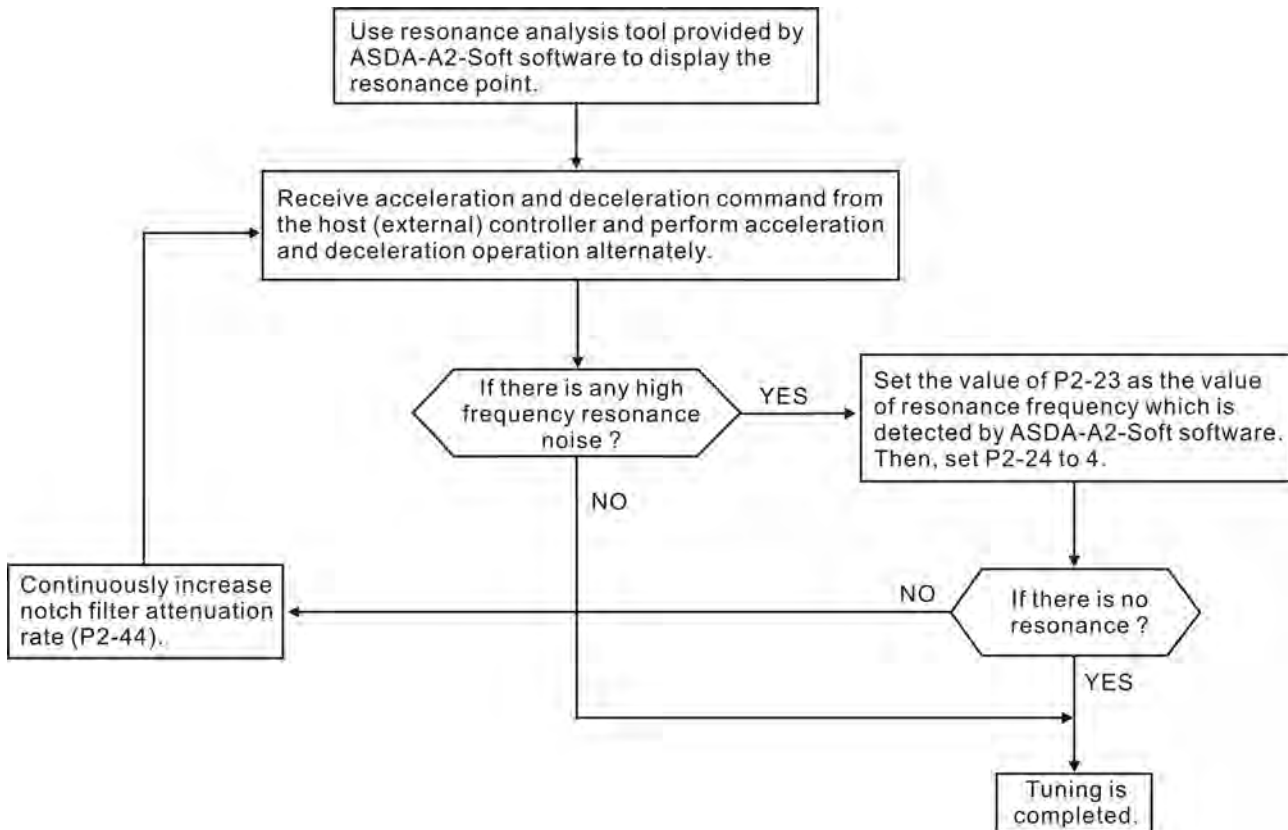
NOTE

- 1) Parameters P2-44 and P2-46 are used to set notch filter attenuation rate. If the resonance can not be suppressed when the setting values of P2-44 and P2-46 are set to 32dB (the maximum value), please decrease the speed loop frequency response. After setting P2-47, the users can check the setting values of P2-44 and P2-46. If the setting value of P2-44 is not 0, it indicates that one resonance frequency exists in the system and then the users can read P2-43, i.e. the frequency (unit is Hz) of the resonance point. When there is any resonance point in the system, its information will be shown in P2-45 and P2-46 as P2-43 and P2-44.
- 2) If the resonance conditions are not improved when P2-47 is set to 1 for over three times, please adjust notch filters (resonance suppression parameters) manually to or eliminate the resonance.

5.6.6 Mechanical Resonance Suppression Method

In order to suppress the high frequency resonance of the mechanical system, ASDA-A2 series servo drive provides three notch filters (resonance suppression parameters) for resonance suppression. Two notch filters can be set to suppress the resonance automatically. If the users do not want to suppress the resonance automatically, these two notch filter can also be set to or eliminate the resonance manually.

Please refer to the following flowchart for manual adjustment.



5.6.7 Relationship between Tuning Modes and Parameters

Tuning Mode	P2-32	AutoSet Parameter	User-defined Parameter	Gain Value
Manual Mode	0 (Default setting)	None	P1-37 (Ratio of Load Inertia to Servo Motor Inertia [J_{load} / J_{motor}]) P2-00 (Proportional Position Loop Gain) P2-04 (Proportional Speed Loop Gain) P2-06 (Speed Integral Compensation) P2-25 (Low-pass Filter Time Constant of Resonance Suppression) P2-26 (External Anti-Interference Gain)	Fixed
Auto Mode [Continuous Adjustment]	1	P1-37 P2-00 P2-02 P2-04 P2-06 P2-25 P2-26 P2-49	P2-31 (Auto Stiffness and Frequency response Level)	Continuous Adjusting (every 30 minutes)
Semi-Auto Mode [Non-continuous Adjustment]	2	P1-37 P2-00 P2-02 P2-04 P2-06 P2-25 P2-26 P2-49	P2-31 (Auto Stiffness and Frequency response Level)	Non-continuous Adjusting (stop after a period of time)

When switching mode #1 to #0, the setting value of P2-00, P2-02, P2-04, P2-06, P2-25, P2-26 and P2-49 will change to the value that measured in #1 auto-tuning mode.

When switching mode #2 to #0, the setting value of P2-00, P2-02, P2-04, P2-06, P2-25, P2-26 and P2-49 will change to the value that measured in #2 semi-auto tuning mode.

5.6.8 Gain Adjustment in Manual Mode

The position and speed frequency response selection is depending on and determined by the the control stiffness of machinery and conditions of applications. Generally, high reponsiveness is essential for the high frequency positioning control of mechanical facilities and the applications of high precision process system. However, the higher frequency response may easily result in the resonance of machinery system. Therefore, for the applications of high frequency response, the machinery system with control stiffness is needed to avoid the resonance. Especially when adjusting the frequency response of unfamiliar machinery system, the users can gradually increase the gain setting value to improve frequency response untill the resonance occurs, and then decrease the gain setting value. The relevant parameters and gain adjusting methods are described as follows:

- KPP, Parameter P2-00 Proportional Position Loop Gain

This parameter is used to determine the frequency response of position loop (position loop gain). It could be used to increase stiffness, expedite position loop response and reduce position error. When the setting value of KPP is higher, the response to the position command is quicker, the position error is less and the settling time is also shorter. However, if the setting value is over high, the machinery system may generate vibration or noise, or even overshoot during positioning. The position loop frequency response is calculated as follows:

$$\text{Position Loop Frequency Response (Hz)} = \frac{KPP}{2\pi}$$

- KVP, Parameter P2-04 Proportional Speed Loop Gain

This parameter is used to determine the frequency response of speed loop (speed loop gain). It could be used to expedite speed loop response. When the setting value of KVP is higher, the response to the speed command is quicker. However, if the setting value is over high, it may result in the resonance of machinery system. The frequency response of speed loop must be higher than the 4~6 times of the frequency response of position loop. If frequency response of position loop is higher than the frequency response of speed loop, the machinery system may generate vibration or noise, or even overshoot during positioning. The speed loop frequency response is calculated as follows:

$$\text{Speed Loop Frequency Response } f_v = \left(\frac{KVP}{2\pi} \right) \times \left[\frac{(1+P1-37/10)}{(1+JL/JM)} \right] \text{Hz}$$

JM: Motor Inertia

JL: Load Inertia

P1-37: 0.1 times

When the value of P1-37 (no matter it is the measured load inertia value or the set load inertia value) is equal to the actual load inertia value, the actual speed loop frequency response will be:

$$f_v = \frac{KVP}{2\pi} \text{ Hz}$$

- **KVI, Parameter P2-06 Speed Integral Compensation**

If the setting value of KVI is higher, the capability of decreasing the speed control deviation is better. However, if the setting value is over high, it may easily result in the vibration of machinery system. The recommended setting value is as follows:

$$\text{KVI (Parameter P2-06)} \leq 1.5 \times \text{Speed Loop Frequency Response}$$

- **NLP, Parameter P2-25 Low-pass Filter Time Constant of Resonance Suppression**

When the value of ($J_{\text{load}} / J_{\text{motor}}$) is high, the frequency response of speed loop may decrease. At this time, the users can increase the setting value of KVP (P2-04) to keep the frequency response of speed loop. However, when increasing the setting value of KVP (P2-04), it may easily result in the vibration of machinery system. Please use this parameter to suppress or eliminate the noise of resonance. If the setting value of NLP is higher, the capability of improving the noise of resonance is better. However, if the setting value is over high, it may easily lead to the instability of speed loop and overshoot of machinery system.

The recommended setting value is as follows:

$$\text{NLP (Parameter P2-25)} \leq \frac{1000}{6 \times \text{Speed Loop Frequency Response (Hz)}}$$

- **DST, Parameter P2-26 External Anti-Interference Gain**

This parameter is used to enhance the anti-interference capability and reduce the occurrence of overshoot. The default setting is 0 (Disabled). It is not recommended to use it in manual mode only when performing a few tuning on the value gotten through P2-32 Auto Mode.

- **PFG, Parameter P2-02 Position Feed Forward Gain**

This parameter is used to reduce position error and shorten the positioning settling time. However, if the setting value is over high, it may easily lead to the overshoot of machinery system. If the value of electronic gear ratio (1-44/1-45) is over than 10, the machinery system may also easily generate vibration or noise.

This page intentionally left blank.

Chapter 6 Control Modes of Operation

6.1 Control Modes of Operation

The Delta ASDA-A2 series can be programmed to provide six single, eight dual modes and two multiple modes of operation. Their operation and description is listed in the following table.

	Mode	Mode	Code	Description
Single Mode	External Position Control	PT	00	Position control for the servo motor is achieved via an external pulse command.
	Internal Position Control	PR	01	Position control for the servo motor is achieved via by internal position commands stored within the servo controller. Execution of the 64 positions is via Digital Input (DI) signals.
	Speed Control	S	02	Speed control for the servo motor can be achieved via parameters set within the controller or from an external analog -10 ~ +10 Vdc command. Control of the internal speed parameters is via the Digital Inputs (DI). (A maximum of three speeds can be stored internally).
	Internal Speed Control	Sz	04	Speed control for the servo motor is only achieved via parameters set within the controller. Control of the internal speed parameters is via the Digital Inputs (DI). (A maximum of three speeds can be stored internally).
	Torque Control	T	03	Torque control for the servo motor can be achieved via parameters set within the controller or from an external analog -10 ~ +10 Vdc command. Control of the internal torque parameters is via the Digital Inputs (DI). (A maximum of three torque levels can be stored internally).
	Internal Torque Control	Tz	05	Torque control for the servo motor is only achieved via parameters set within the controller. Control of the internal torque parameters is via the Digital Inputs (DI). (A maximum of three torque levels can be stored internally).

Mode	Mode	Code	Description
Dual Mode	PT-S	06	Either PT or S control mode can be selected via the Digital Inputs (DI)
	PT-T	07	Either PT or T control mode can be selected via the Digital Inputs (DI).
	PR-S	08	Either PR or S control mode can be selected via the Digital Inputs (DI).
	PR-T	09	Either PR or T control mode can be selected via the Digital Inputs (DI).
	S-T	0A	Either S or T control mode can be selected via the Digital Inputs (DI).
	CANopen	0B	CANopen communication control is achieved via the commands from the host (external) controller.
	Reserved	0C	Reserved
Multiple Mode	PT-PR	0D	Either PT or PR control mode can be selected via the Digital Inputs (DI).
	PT-PR-S	0E	Either PT or PR or S control mode can be selected via the Digital Inputs (DI).
	PT-PR-T	0F	Either PT or PR or T control mode can be selected via the Digital Inputs (DI).

The steps of changing mode:

- (1) Switching the servo drive to Servo Off status. Turning SON signal of digit input to be off can complete this action.
- (2) Using parameter P1-01. (Refer to chapter 8).
- (3) After the setting is completed, cut the power off and restart the drive again.

The following sections describe the operation of each control mode, including control structure, command source and loop gain adjustment, etc.

6.2 Position Control Mode

The position control mode (PT or PR mode) is usually used for the applications requiring precision positioning, such as industry positioning machine, indexing table etc. Delta ASDA-A2 series servo drives support two kinds of command sources in position control mode. One is an external pulse train (PT: Position Terminals, External Position Control) and the other is internal parameter (PR: Position Register, i.e. internal parameters P6-00 to P7-27, Internal Position Control). The external pulse train with direction which can control the rotation angle of servo motor. The max. input frequency for the external pulse command is 4MKpps.

In order to provide a convenient position control function, Delta servo drive provides 64 internal preset parameters for position control. There are two setting methods of internal parameters, one is to set different position command into these 64 internal parameters before operation and then use POS0~POS5 of DI signals of CN1 to perform positioning control. The other setting method is to use serial communication to change the setting value of these eight internal parameters.

To make the servo motor and load operate more smoothly, Delta servo drive also provide complete Position Spine Line (P-curve) profile for position control mode. For the closed-loop positioning, speed control loop is the principal part and the auxiliary parameters are position loop gain and feed forward compensation. The users can also select two kinds of tuning mode (Manual/Auto modes) to perform gain adjustment. This Section 6.2 mainly describes the applicability of loop gain adjustment and feed forward compensation of Delta servo system.

6.2.1 Command Source of Position (PT) Control Mode

The command source of P mode is external pulse train input form terminals.

There are three types of pulse input and each pulse type is with-logic type (positive (+), negative (-)). They all can be set in parameter P1-00. Please refer to the following relevant parameters:

Relevant Parameter:

P1 - 00▲	PTT	External Pulse Input Type	Address: 0100H, 0101H
-----------------	------------	----------------------------------	------------------------------

Default: 0x2

Related Section:

Applicable Control Mode: PT

Section 6.2.1

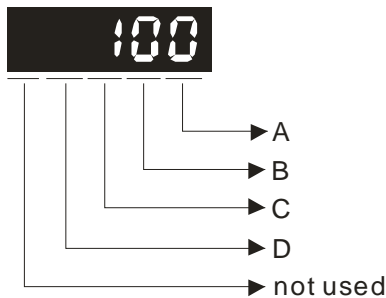
Unit: N/A

Range: 0 ~ 1132

Data Size: 16-bit

Display Format: Hexadecimal

Settings:



A: Input pulse type

0: AB phase pulse (4x) (Quadrature Input)

1: Clockwise (CW) + Counterclockwise (CCW) pulse

2: Pulse + Direction

3: Other settings:

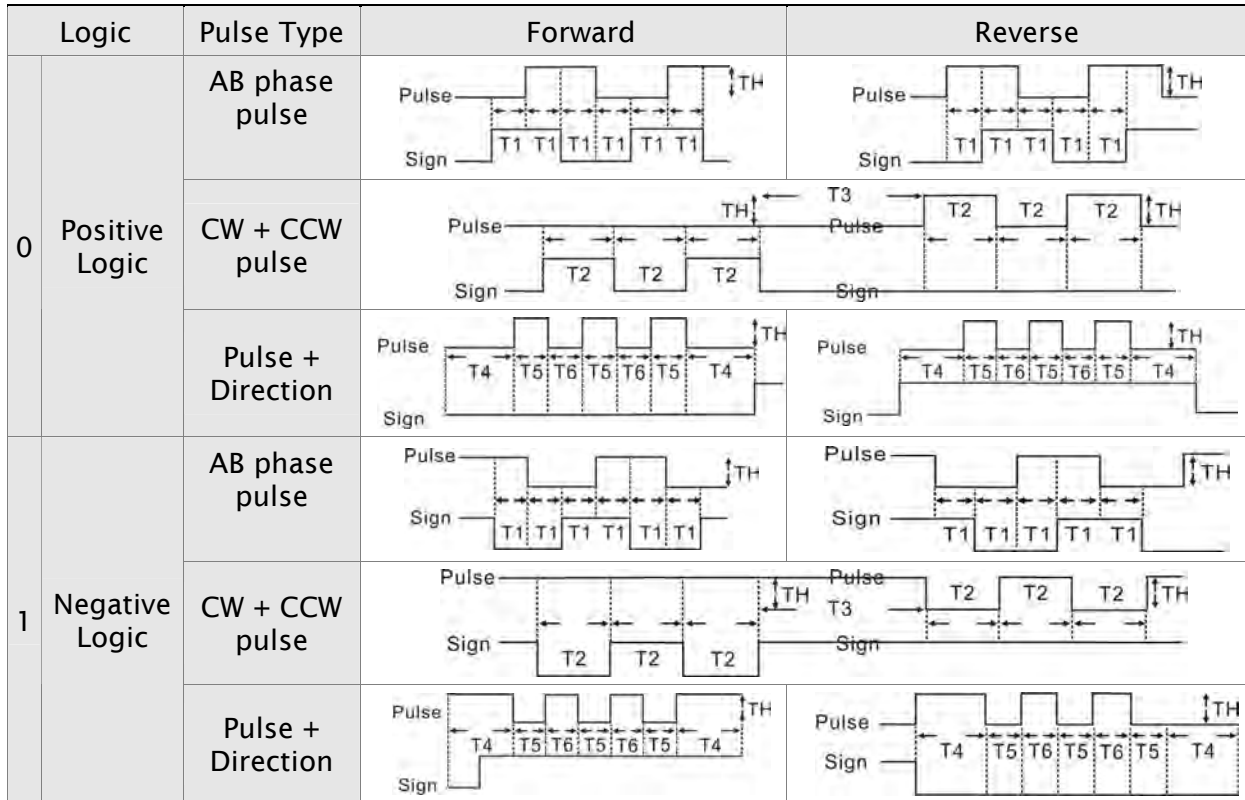
B: Input pulse filter

This setting is used to suppress or reduce the chatter caused by the noise, etc.

However, if the instant input pulse filter frequency is over high, the frequency that exceeds the setting value will be regarded as noise and filtered.

Setting Value	Low Filter	Setting Value	High Filter
0	1.66Mpps	0	6.66Mpps
1	416Kpps	1	1.66Mpps
2	208Kpps	2	833Kpps
3	104Kpps	3	416Kpps
4	No Filter Function	4	No Filter Function

C: Input polarity



Pulse specification		Max. input pulse frequency	Min. time width					
			T1	T2	T3	T4	T5	T6
High-speed pulse	Line driver	4Mpps	62.5ns	125ns	250ns	200ns	125ns	125ns
Low-speed pulse	Line driver	500Kpps	0.5 μs	1 μs	2 μs	2 μs	1 μs	1 μs
	Open collector	200Kpps	1.25 μs	2.5 μs	5 μs	5 μs	2.5 μs	2.5 μs

Pulse specification		Max. input pulse frequency	Voltage specification	Forward specification
High-speed pulse	Line driver	4Mpps	5V	< 25mA
Low-speed pulse	Line driver	500Kpps	2.8V ~ 3.7V	< 25mA
	Open collector	200Kpps	24V (Max.)	< 25mA

D: Source of pulse command

Setting value	Input pulse interface	Remark
0	Open collector for low-speed pulse	CN1 Terminal Identification: PULSE, SIGN
1	Line driver for high-speed pulse	CN1 Terminal Identification: PULSE_D, SIGN_D

Position pulse can be input from these terminals, PULSE (41), /PULSE (43), HPULSE (38), /HPULSE (29), SIGN (37), /SIGN (36) and HSIGN (46), /HSIGN (40). It can be an open-collector circuit or line driver circuit. For the detail wiring, please refer to 3.10.1.

6.2.2 Command Source of Position (PR) Control Mode

The command sources of PR mode are (P6-00, P6-01) ~ (P7-26, P7-27) these 64 built-in parameters. Using with external I/O signals (CN1, POS 0 to POS 5 and CTRG) can select one of the 64 built-in parameters to be position command. Please refer to the table below:

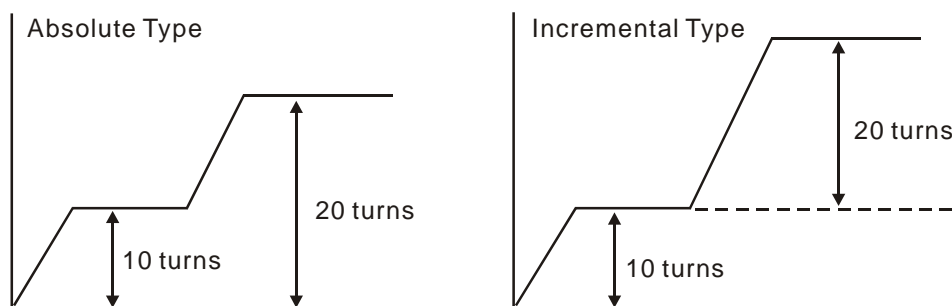
Position Command	POS5	POS4	POS3	POS2	POS1	POS0	CTRG	Parameters
P1	ON	ON	ON	ON	ON	ON	↑	P6-00 P6-01
P2	ON	ON	ON	ON	ON	OFF	↑	P6-02 P6-03
~								~
P50	OFF	OFF	ON	ON	OFF	ON	↑	P6-98 P6-99
P51	OFF	OFF	ON	ON	OFF	OFF	↑	P7-00 P7-01
~								~
P64	OFF	OFF	OFF	OFF	OFF	OFF	↑	P7-26 P7-27

State of POS0~5: 0 indicates the contact is OFF (Normally Open)

1 indicates the contact is ON (Normally Closed)

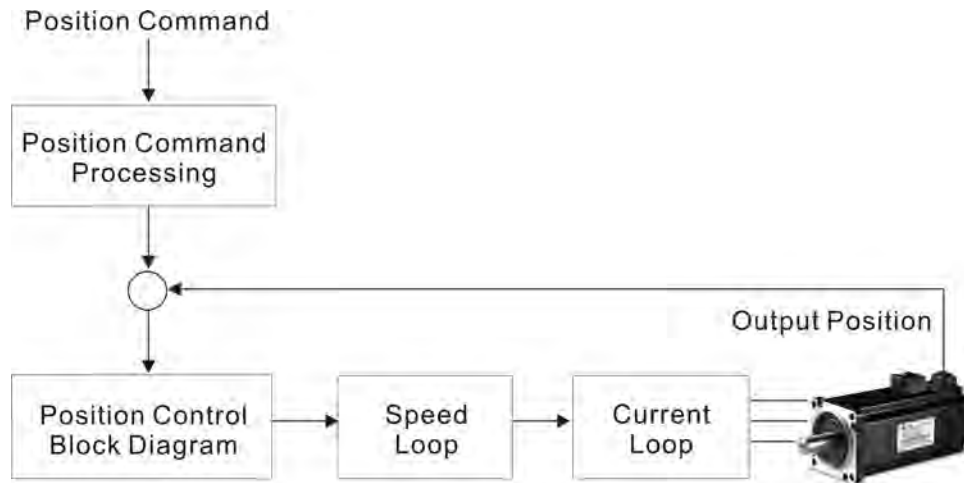
CTRG↑: the instant time when the contact changes from 0 (open) to 1 (closed).

The application of absolute and incremental position control is various and multiple. This kind of position control is equal to a simple sequence control. Users can easily complete the cycle running by using the above table. For example, the position command, P1 is 10 turns and P2 is 20 turns. Give the position command P1 first and then give the position command P2. The difference between absolute and incremental position control is shown as the figure below:



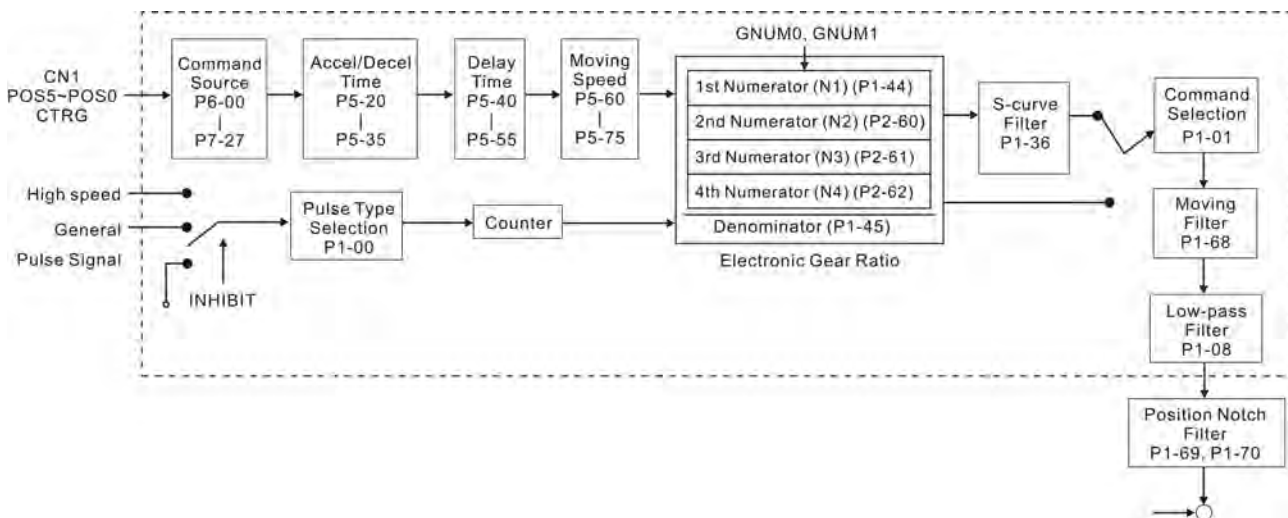
6.2.3 Structure of Position Control Mode

Basic Structure:



In order to pursue the goal of perfection in position control, the pulse signal should be modified through position command processing and the structure is shown as the figure below:

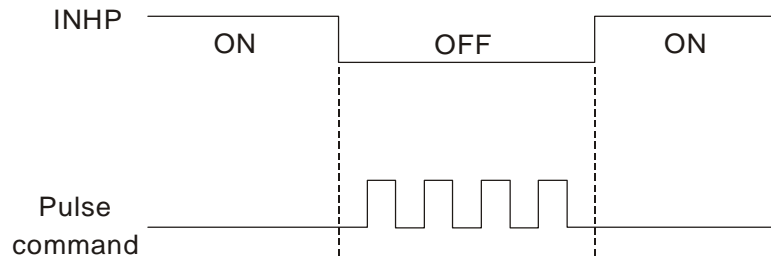
ASDA-A2 Series:



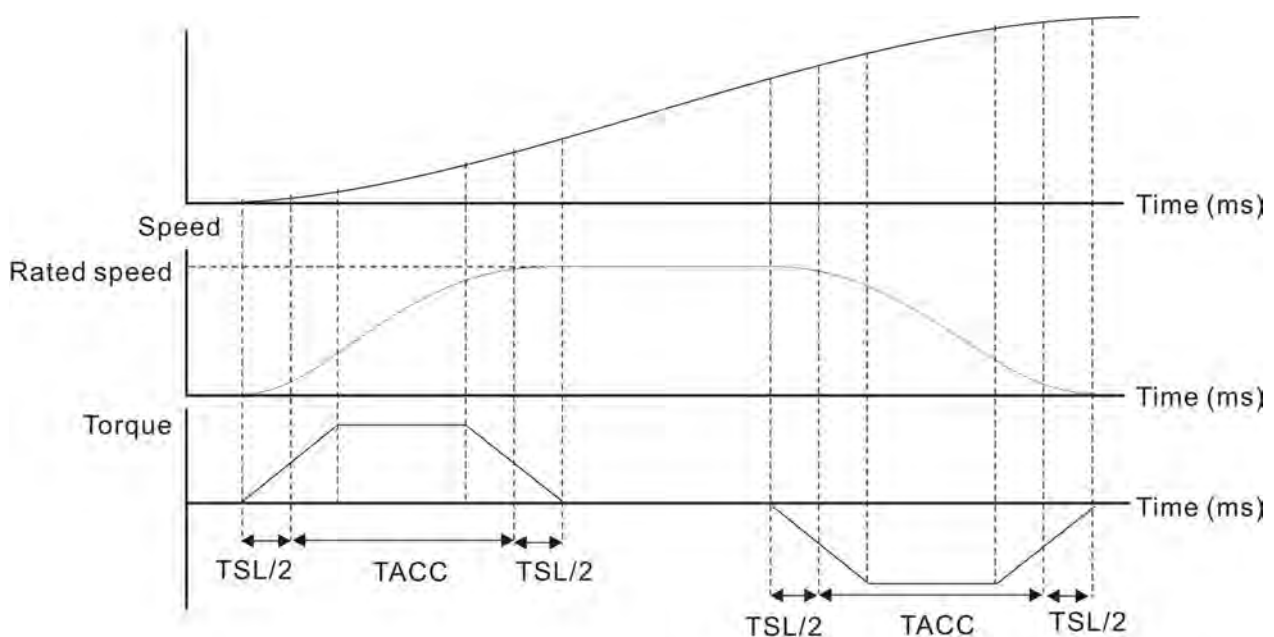
Using parameter can select PR mode and PT mode. Electronic gear ratio can be set in both two modes to set proper position revolution. ASDA-A2 series servo drives also provide S-curve and low-pass filter, which are used whenever the motor and load need to be operated more smoothly. As for the information of electronic gear ratio, S-curve and low-pass filter, please refer to the following sections 6.2.4, 6.2.5 and 6.2.6.

Pulse Inhibit Input Function (INHIBIT)

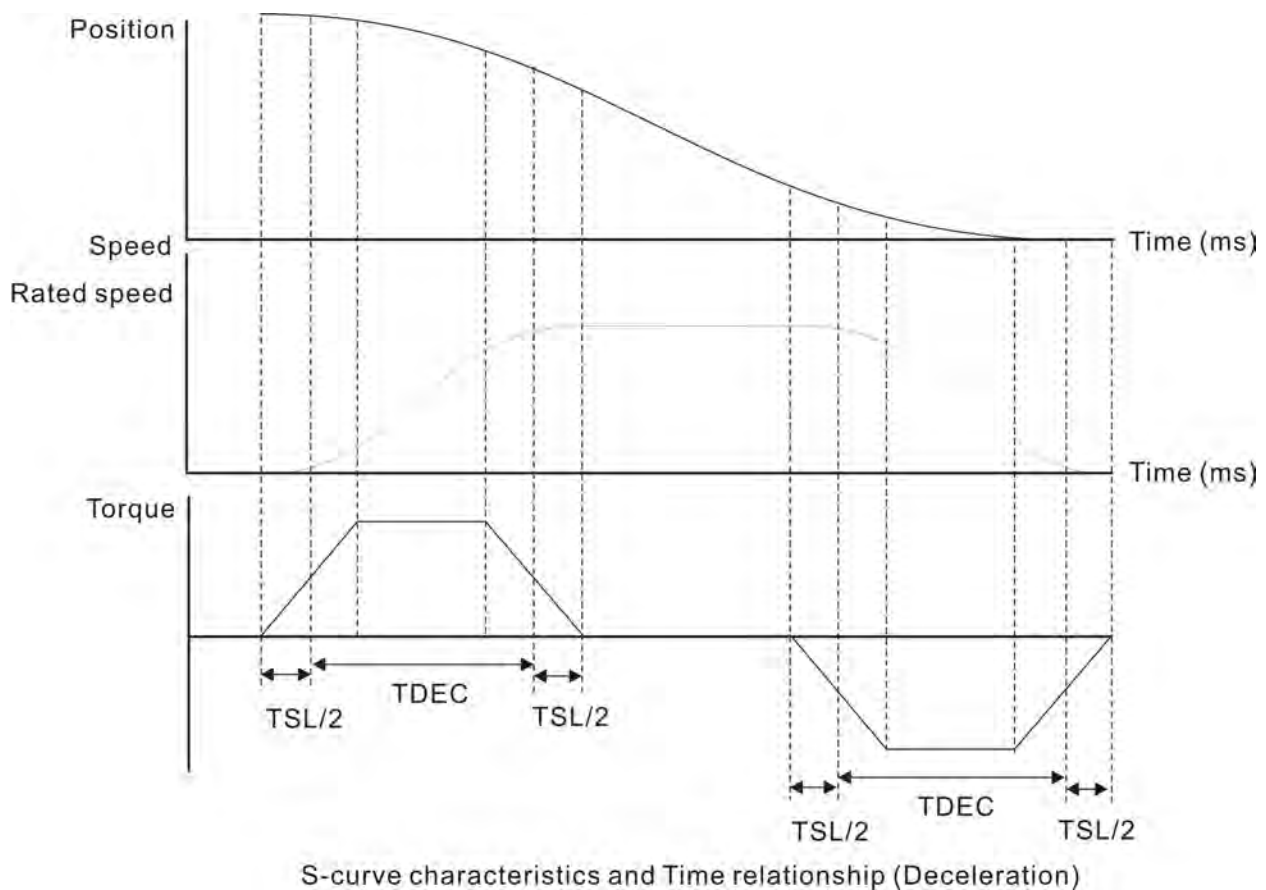
This function is activated via digital inputs (Please refer to parameter P2-10 ~ P2-17 and DI INHP in Table 8.A). When the drive is in position mode, if INHP is activated, the external pulse input command is not valid and the motor will stop (Please note that only DI8 supports this function).

**6.2.4 S-curve Filter for Position Control**

The S-curve filter is for the position smoothing of motion command. Using S-curve filter can run the servo motor more smoothly in response to a sudden position command. Since the speed and acceleration curve are both continuous and the time for the servo motor to accelerate is short, using S-curve filter not only can improve the performance when servo motor accelerate or decelerate but also can make motor to operate more smoothly (from mechanical view). When the load is change, the motor usually run not smoothly when starts to run and stop due to the friction and inertia change. At this moment, users can increase Accel/Decel S-curve constant (TSL), Accel time constant (TACC) and Decel time constant (TDEC) to improve the performance. Because the speed and angle acceleration are continuous when position command is changed to pulse signal input, so it is not needed to use S-curve filter.



S-curve characteristics and Time relationship (Acceleration)



Relevant Parameters:

P1 - 34	TACC	Acceleration Time	Address: 0144H, 0145H
----------------	-------------	--------------------------	------------------------------

Default: 200

Applicable Control Mode: S

Unit: msec

Range: 1 ~ 65500

Data Size: 16-bit

Display Format: Decimal

Settings:

This parameter is used to determine the acceleration time to accelerate from 0 to its rated motor speed. The functions of parameters P1-34, P1-35 and P1-36 are each individual. When P1-36 is set to 0 (Disabled), the settings of P1-34, P1-35 are still effective. It indicates that the parameters P1-34 and P1-35 will not become disabled even when P1-36 is disabled.

Please note:

1. When the source of speed command is analog command, the maximum setting value of P1-36 is set to 0, the acceleration and deceleration function will be disabled.
2. When the source of speed command is analog command, the maximum setting value of P1-34 is limited to 20000 automatically.

P1 - 35	TDEC	Deceleration Time	Address: 0146H, 0147H
----------------	-------------	--------------------------	------------------------------

Default: 200

Related Section:

Applicable Control Mode: S

Section 6.3.3,

Unit: msec

Range: 1 ~ 65500

Data Size: 16-bit

Display Format: Decimal

Settings:

This parameter is used to determine the acceleration time to accelerate from 0 to its rated motor speed. The functions of parameters P1-34, P1-35 and P1-36 are each individual. When P1-36 is set to 0 (Disabled), the settings of P1-34, P1-35 are still effective. It indicates that the parameters P1-34 and P1-35 will not become disabled even when P1-36 is disabled.

Please note:

1. When the source of speed command is analog command, the maximum setting value of P1-36 is set to 0, the acceleration and deceleration function will be disabled.
2. When the source of speed command is analog command, the maximum setting value of P1-35 is limited to 20000 automatically.

P1 - 36	TSL	Accel /Decel S-curve	Address: 0148H, 0149H
----------------	------------	-----------------------------	------------------------------

Default: 0

Related Section:

Unit: msec

Section 6.3.3,

Applicable Control Mode: S, PR

Unit: msec

Range: 0 ~ 65500 (0: Disabled)

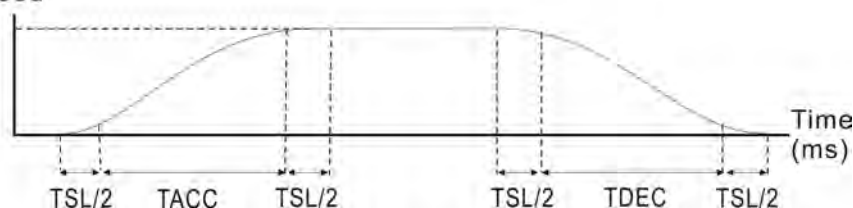
Data Size: 16-bit

Display Format: Decimal

Settings:

This parameter is used to make the motor run more smoothly when startup and windup. Using this parameter can improve the motor running stability.

Speed



TACC: P1-34, Acceleration time

TDEC: P1-35, Deceleration time

TSL: P1-36, Accel /Decel S-curve

Total acceleration time = TACC + TSL

Total deceleration time = TDEC + TSL

The functions of parameters P1-34, P1-35 and P1-36 are each individual. When P1-36 is set to 0 (Disabled), the settings of P1-34, P1-35 are still effective. It indicates that the parameters P1-34 and P1-35 will not become disabled even when P1-36 is disabled.

Please note:

1. When the source of speed command is analog command, the maximum setting value of P1-36 is set to 0, the acceleration and deceleration function will be disabled.
2. When the source of speed command is analog command, the maximum setting value of P1-36 is limited to 10000 automatically.

6.2.5 Electronic Gear Ratio

Relevant parameters:

P1 - 44▲	GR1	Electronic Gear Ratio (1st Numerator) (N1)	Address: 0158H, 0159H
-----------------	------------	---	------------------------------

Default: 128

Related Section:

Applicable Control Mode: PT, PR

Section 6.2.5

Unit: pulse

Range: 1 ~ (2²⁹-1)

Data Size: 32-bit

Display Format: Decimal

Settings:

This parameter is used to set the numerator of the electronic gear ratio. The denominator of the electronic gear ratio is set by P1-45. P2-60 ~ P2-62 are used to set the additional numerators.

Please note:

1. In PT mode, the setting value of P1-44 can be changed only when the servo drive is enabled (Servo On).
2. In PR mode, the setting value of P1-44 can be changed only when the servo drive is disabled (Servo Off).

P1 - 45▲	GR2	Electronic Gear Ratio (Denominator) (M)	Address: 015AH, 015BH
-----------------	------------	--	------------------------------

Default: 10

Related Section:

Applicable Control Mode: PT, PR

Section 6.3.6

Unit: pulse

Range: 1 ~ (2³¹-1)

Data Size: 32-bit

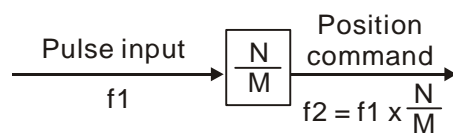
Display Format: Decimal

Settings:

This parameter is used to set the denominator of the electronic gear ratio. The numerator of the electronic gear ratio is set by P1-44. P2-60 ~ P2-62 are used to set the additional numerators.

As the wrong setting may cause motor to run chaotically (out of control) and it may lead to personnel injury, therefore, ensure to observe the following rule when setting P1-44, P1-45.

The electronic gear ratio setting (Please also see P1-44, P2-60 ~ P2-62):



f1: Pulse input

f2: Position command

N: Numerator, the setting value of P1-44 or P2-60 ~ P2-62

M: Denominator, the setting value of P1-45

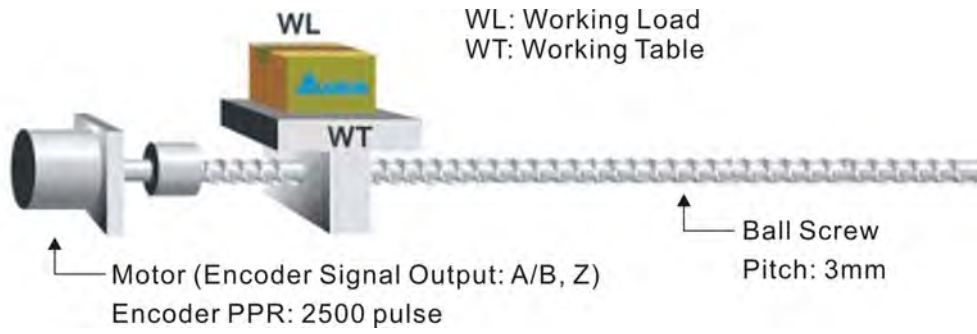
The electronic gear ratio setting range must be within: $1/50 < N/M < 25600$.

Please note:

1. In PT and PR mode, the setting value of P1-45 can not be changed when the servo drive is enabled (Servo On).

The electronic gear function provides easy travel distance ratio change. However, the over high electronic gear ratio will command the motor to move not smoothly. At this time, the users can use low-pass filter parameter to improve this kind of situation. For example, assume that the electronic gear ratio is equal to 1 and the encoder pulse per revolution is 10000ppr, if the electronic gear ratio is changed to 0.5, then the motor will rotate one pulse when the command from external controller is two pulses.

For example, after the proper electronic gear ratio is set, the reference travel distance is 1 μm/pulse, the machinery will become easier to be used.



	Electronic Gear Ratio	Corresponding travel distance per pulse
When the electronic gear ratio is not used	$= \frac{1}{1}$	$= \frac{3 \times 1000}{4 \times 2500} = \frac{3000}{10000} \mu\text{m}$
When the electronic gear ratio is not used	$= \frac{10000}{3000}$	$= 1 \mu\text{m}$

6.2.6 Low-pass Filter

Relevant parameters:

P1 - 08	PFLT	Smooth Constant of Position Command (Low-pass Filter)	Address: 0110H, 0111H
----------------	-------------	--	------------------------------

Default: 0

Related Section:

Applicable Control Mode: PT/PR

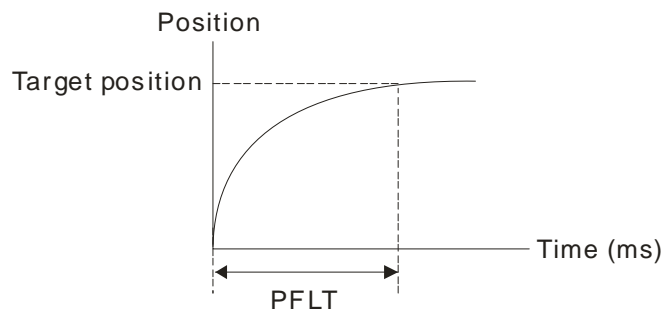
Section 6.2.6

Unit: 10msec

Range: 0 ~ 1000 (0: Disabled)

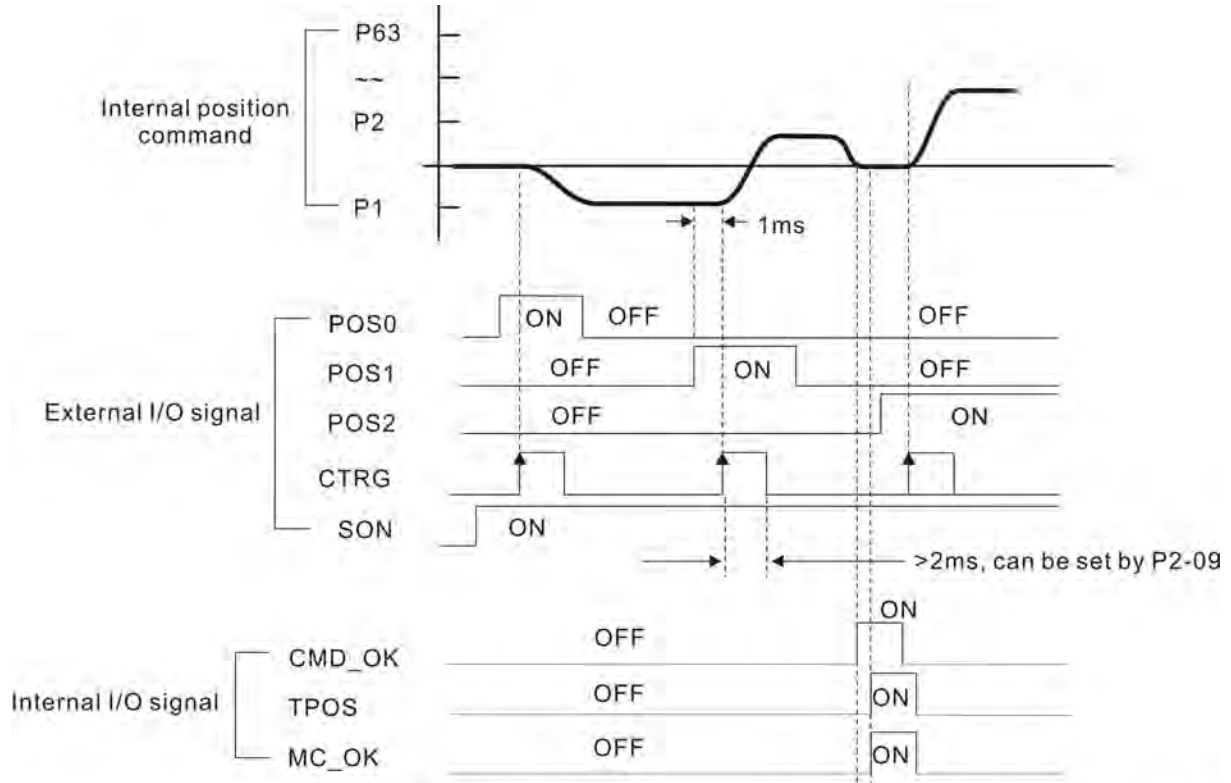
Data Size: 16-bit

Display Format: Decimal



6.2.7 Timing Chart of Position (PR) Control Mode

In PR mode, position command source is DI signal from CN1, i.e. selected by POS0~POS5 and CTRG. Please refer to 6-2-2 to see the relationship between DI signals and parameters. The following figure is shown the timing chart of PR mode:



CMD_OK : CMD_OK is activated when the servo drive has detected that Pr command has been completed

TPOS : TPOS will be activated when the drive detects that the position of the motor is in a -P1-54 to +P1-54 band of the target position.

MC_OK : MC_OK is activated when CMD_OK and TPOS are both ON.

6.2.8 Position Loop Gain Adjustment

Before performing position control (setting position control block diagram), the users should complete the speed control setting by using Manual mode (parameter P-32) since the position loop contains speed loop. Then, adjust the Proportional Position Loop Gain, KPP (parameter P2-00) and Position Feed Forward Gain, PFG (parameter P2-02). Or use Auto mode to adjust the gain of speed and position control block diagram automatically.

- 1) Proportional Position Loop Gain: To increase this gain can enhance the position loop responsiveness.
- 2) Position Feed Forward Gain: To increase this gain can reduce the position track error during operation.

The position loop responsiveness cannot exceed the speed loop responsiveness, and it is recommended that the speed loop responsiveness should be at least four times faster than the position loop responsiveness. This also means that the setting value of Proportional Speed Loop Gain, KVP should be at least four times faster than Proportional Position Loop Gain, KPP.

The equation is shown as follows:

$$f_p \leq \frac{f_v}{4}, \quad f_v : \text{Speed Loop Responsiveness (Hz)}, \quad f_p : \text{Position Loop Responsiveness (Hz)}$$

$$KPP = 2 \times \pi \times f_p.$$

For example, the desired position loop responsiveness is equal to 20 Hz.

Then, $KPP = 2 \times \pi \times 20 = 125 \text{ rad/s}$.

Relevant parameters:

P2 - 00	KPP	Proportional Position Loop Gain	Address: 0200H, 0201H
---------	-----	---------------------------------	-----------------------

Default: 35

Related Section:

Applicable Control Mode: PT, PR

Section 6.2.8

Unit: rad/s

Range: 0 ~ 2047

Data Size: 16-bit

Display Format: Decimal

Settings:

This parameter is used to set the position loop gain. It can increase stiffness, expedite position loop response and reduce position error. However, if the setting value is over high, it may generate vibration or noise.

P2 - 02	PFG	Position Feed Forward Gain	Address: 0204H, 0205H
----------------	------------	-----------------------------------	------------------------------

Default: 50

Related Section:

Applicable Control Mode: PT, PR

Section 6.2.8

Unit: %

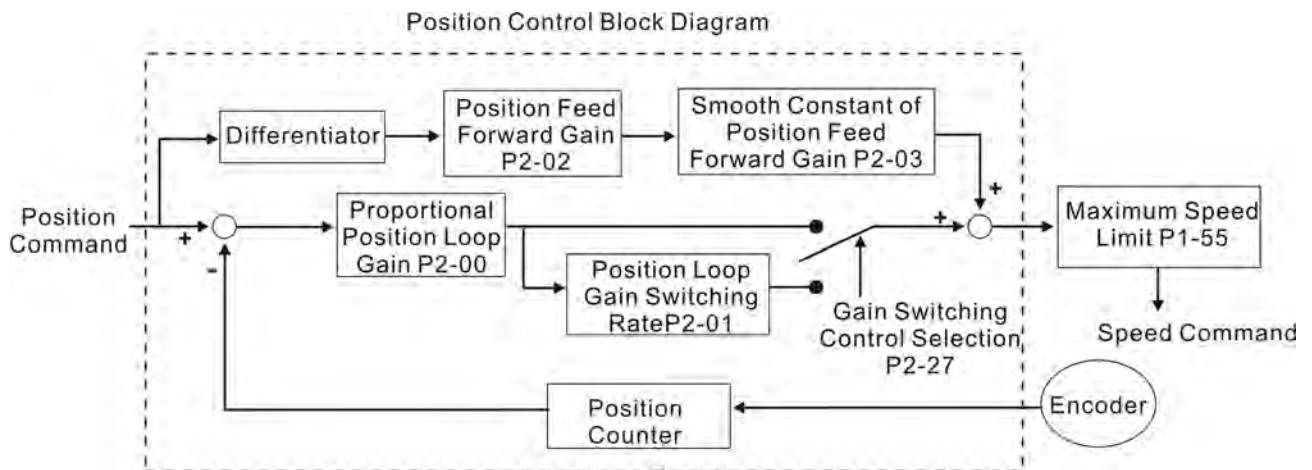
Range: 0 ~ 100

Data Size: 16-bit

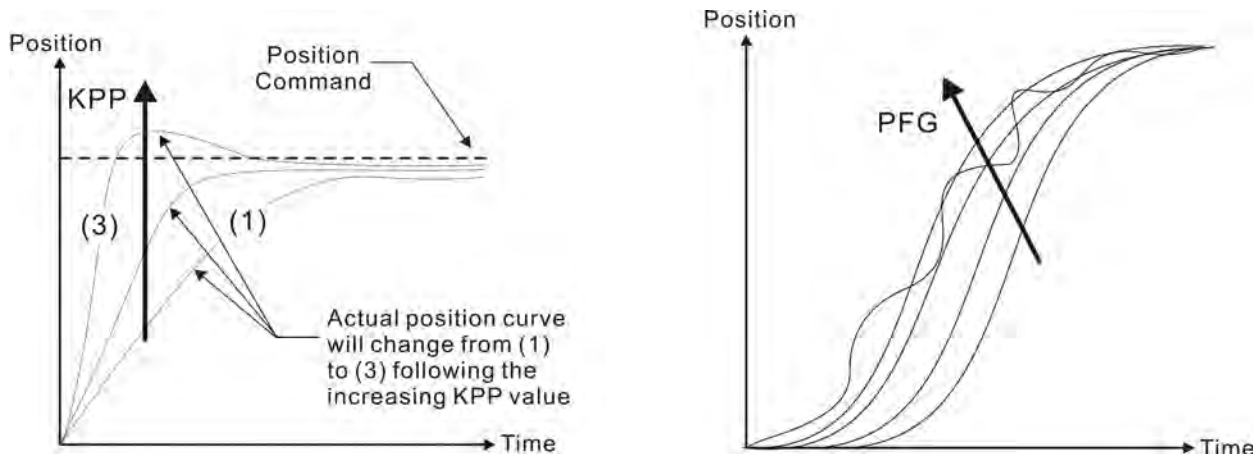
Display Format: Decimal

Settings:

This parameter is used to set the feed forward gain when executing position control command. When using position smooth command, increase gain can improve position track deviation. When not using position smooth command, decrease gain can improve the resonance condition of mechanical system.



When the value of Proportional Position Loop Gain, KPP is too great, the position loop responsiveness will be increased and it will result in small phase margin. If this happens, the rotor of motor will oscillate. At this time, the users have to decrease the value of KPP until the rotor of motor stop oscillating. When there is an external torque command interrupted, over low KPP value will let the motor cannot overcome the external strength and fail to meet the requirement of reasonable position track error demand. Adjust feed forward gain, PFG (P2-02) to efficiently reduce the dynamic position track error.

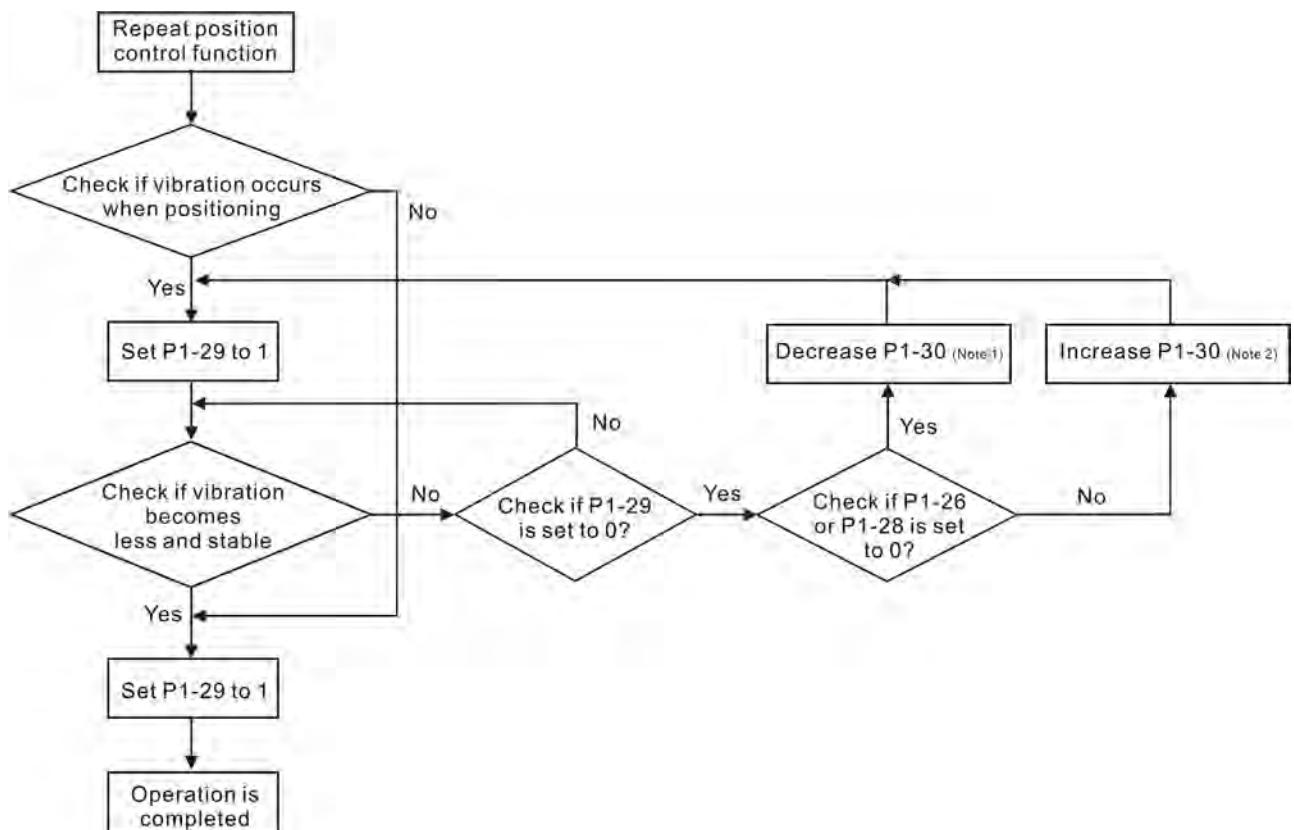


6.2.9 Low-frequency Vibration Suppression

If the stiffness of the mechanical system is not sufficient, after the positioning command has completed, continuous vibration of the mechanical system may occur still even when the motor has almost stopped. At this time, using low-frequency vibration suppression function can suppress the low-frequency vibration of mechanical system. The range of frequency setting is from 1.0 to 100.0Hz. Besides, two modes (Manual/Auto) of low-frequency vibration suppression function are available for the users to select.

■ Auto Mode

If the users know the point where the low-frequency occurs, we recommend the users can use this mode to find the low-frequency of the mechanical vibration automatically. When P1-29 is set to 1, the system will disable the filter function and find the vibration frequency of low-frequency automatically. After the detected frequency becomes fixed and stable, the system will set P1-29 to 0, save the first measured low-frequency value automatically into P1-25 and set P1-26 to 1; then save the second measured low-frequency value automatically into P1-27 and set P1-28 to 1. If any low-frequency vibration occurs after P1-29 is set to 0 automatically, please examine if the function of P1-26 or P1-28 is enabled or not. When the setting value of P1-26 or P1-28 is 0, it indicates that there is no frequency is detected. Please decrease the setting value of P1-30 (Low-frequency Vibration Detection Level) and set P1-29 to 1 to find the low-frequency again. Please pay close attention on the setting value of P1-30 as if the setting value of P1-30 is too low, it is easy to regard the interference as the low-frequency and results in erroneous measurement.



Please note:

1. When P1-26 and P1-28 are both set to 0, it indicates that the system could not find the frequency. Please check the setting value of P1-30 because when the setting value of P1-30 is too high, it may causes that the frequency becomes difficult to be found.
2. When P1-26 and P1-28 are both set to a non-zero value, if the vibration condition can not be improved, please check the setting value of P1-30 as the low setting value of P1-30 may result in erroneous measurement. The system may regard the interference as a low-frequency.
3. When the vibration still exists and can not be suppressed after using auto low-frequency vibration suppression function, if the users know the vibration frequency, please set P1-25 and P1-27 manually to improve the vibration condition.

Relevant parameters:

P1 - 29	AVSM	Auto Low-frequency Vibration Suppression Mode Selection	Address: 013AH, 013BH
----------------	-------------	--	------------------------------

Default: 0

Applicable Control Mode: PT/PR

Unit: -

Range: 0 ~ 1

Data Size: 16-bit

Display Format: Decimal

Settings:

0: Normal mode (Disable Auto Low-frequency Vibration Suppression Mode).

1: Auto mode (Enable Auto Low-frequency Vibration Suppression Mode).

Explanation:

If P1-29 is set to 0, the setting of low-frequency vibration suppression is fixed and will not change automatically.

If P1-29 is set to 1, when there is no low-frequency vibration or the low-frequency vibration becomes less and stable, the system will set P1-29 to 0, save the measured low-frequency value automatically and memorize it in P1-25.

Related Section:

Section 6.2.9

P1 - 30	VCL	Low-frequency Vibration Detection Level	Address: 013CH, 013DH
----------------	------------	--	------------------------------

Default: 500

Applicable Control Mode: PT/PR

Unit: pulse

Range: 1 ~ 8000

Data Size: 16-bit

Display Format: Decimal

Related Section:

Section 6.2.9

Settings:

When P1-29 is set to 1, the system will find this detection level automatically. If the setting value of P1-30 is too low, the detection of frequency will become sensitive and result in erroneous measurement. If the setting value of P1-30 is too high, although the probability of erroneous measurement will decrease, the frequency will become difficult to be found especially when the vibration of mechanical system is less.

The setting value of P1-30 indicates the range of vibration frequency. When the vibration can not be detected (out of range), it indicates that the setting value of P1-30 is too high and we recommend the users can decrease the setting value of P1-30. The users can also use the Scope function provided in ASDA-A2 configuration software to observe the vibration during positioning operation so as to set P1-30 appropriately.

■ Manual Mode

There are two groups of low-frequency vibration suppression parameters. The first group is P1-25 and P1-26 and the second group is P1-27 and P1-28. Using these two groups of parameters can improve the vibration condition of two different low frequencies. P1-25 and P1-26 are used to set the occurred vibration frequency and P1-26 and P1-28 are used to set the frequency response after filter function is used. When the setting values of P1-26 and P1-28 are higher, the performance of frequency response will be better. However, if the setting value is over high, it may affect the motor operation. The default setting of P1-26 and P1-28 are both 0, and it indicates that the low-frequency vibration suppression function is disabled.

Relevant parameters:

P1 - 25	VSF1	Low-frequency Vibration Suppression (1)	Address: 0132H, 0133H
----------------	-------------	--	------------------------------

Default: 100.0

Related Section:

Applicable Control Mode: PT/PR

Section 6.2.9

Unit: Hz

Range: 1.0 ~ 100.0

Data Size: 16-bit

Display Format: Decimal

Settings:

This parameter is used to set the first group of the low-frequency of mechanical system. It can be used to suppress the low-frequency vibration of mechanical system. If P1-26 is set to 0, this parameter is disabled.

P1 - 26	VSG1	Low-frequency Vibration Suppression Gain (1)	Address: 0134H, 0135H
----------------	-------------	---	------------------------------

Default: 0

Related Section:

Applicable Control Mode: PT/PR

Section 6.2.9

Unit: -

Range: 0 ~ 9 (0: Disable the function of P1-25)

Data Size: 16-bit

Display Format: Decimal

Settings:

This parameter is used to set the vibration suppression gain for P1-25. When the setting value is higher, the position response is quicker. However, if the setting value is over high, it may affect the normal operation of servo motor. It is recommended to set P1-26 as 1.

P1 - 27	VSF2	Low-frequency Vibration Suppression (2)	Address: 0136H, 0137H
----------------	-------------	--	------------------------------

Default: 100.0

Related Section:

Applicable Control Mode: PT/PR

Section 6.2.9

Unit: Hz

Range: 1.0 ~ 100.0

Data Size: 16-bit

Display Format: Decimal

Settings:

This parameter is used to set the second group of the low-frequency of mechanical system. It can be used to suppress the low-frequency vibration of mechanical system. If P1-28 is set to 0, this parameter is disabled.

P1 - 28	VSG2	Low-frequency Vibration Suppression Gain (2)	Address: 0138H, 0139H
----------------	-------------	---	------------------------------

Default: 0

Related Section:

Applicable Control Mode: PT/PR

Section 6.2.9

Unit: -

Range: 0 ~ 9 (0: Disable the function of P1-27)

Data Size: 16-bit

Display Format: Decimal

Settings:

This parameter is used to set the vibration suppression gain for P1-27. When the setting value is higher, the position response is quicker. However, if the setting value is over high, it may affect the normal operation of servo motor. It is recommended to set P1-28 as 1.

Please note:

1. After the low-frequency vibration is suppressed, the changes of the response may become excessive. Therefore, please ensure that the machine is able to stop any time and ensure the safety of personnel working with the machine when execute low-frequency vibration suppression function.
2. The low-frequency vibration suppression function can be enabled only in position control mode (PT, PR or PR-PT mode).
3. When the users use resonance suppression function, the resonance condition can be improved immediately after the correct resonance frequency is found. However, when the users use low-frequency vibration suppression function, the vibration of the mechanical system will not be eliminated immediately. The vibration condition is improved gradually after the correct frequency is found. This is because the low-frequency vibration suppression function is not effective for the vibration caused by external force and the vibration occurred before using suppression function.
4. After the low-frequency vibration suppression function is enabled, it will certainly affect the original response performance. When the value of the low-frequency is lower, the effect upon the response performance is greater. At this time, the users can adjust the setting value of P1-26 to increase the position response. But, please do not set P1-26 to a higher value. If the setting value of P1-26 is too high, it will affect the motor operation.
5. In order to avoid that the vibration frequency may not easily to be found when the commanding time is too fast in Auto mode, we recommend the users can set a longer command delay time. The command can be given after the vibration frequency is found.

6.3 Speed Control Mode

The speed control mode (S or Sz) is usually used on the applications of precision speed control, such as CNC machine, etc. ASDA-A2 series servo drives support two kinds of command sources in speed control mode. One is external analog signal and the other is internal parameter. The external analog signal is from external voltage input and it can control the speed of servo motor. There are two usage of internal parameter, one is set different speed command in three speed control parameters before operation and then using SPD0 and SPD1 of CN1 DI signal perform switching. The other usage is using serial communication to change the setting value of parameter.

Beside, in order to make the speed command switch more smoothly, ASDA-A2 series servo drives also provide complete S-curve profile for speed control mode. For the closed-loop speed control, ASDA-A2 series servo drives provide gain adjustment function and an integrated PI or PDF controller. Besides, two modes of tuning technology (Manual/Auto) are also provided for the users to select (parameter P2-32).

There are two turning modes for gain adjustment: Manual and Auto modes.

- **Manual Mode:** User-defined loop gain adjustment. When using this mode, all auto and auxiliary function will be disabled.
- **Auto Mode:** Continuous adjustment of loop gains according to measured inertia, with ten levels of system bandwidth. The parameter set by user is default value.

6.3.1 Command Source of Speed Control Mode

Speed command Sources:

- 1) External analog signal: External analog voltage input, -10V to +10V
- 2) Internal parameter: P1-09 to P1-11

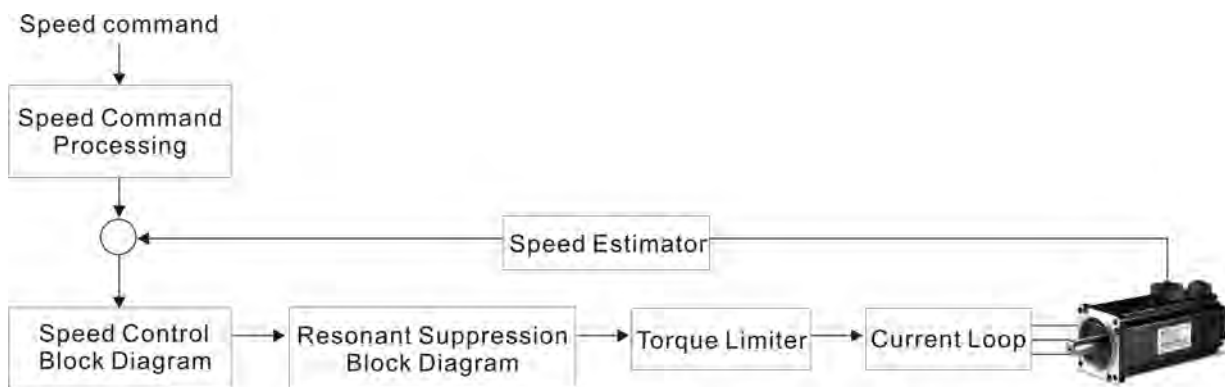
Speed Command	CN1 DI signal		Command Source		Content	Range
	SPD1	SPD0				
S1	0	0	Mode	S	Voltage between V-REF-GND	-10 V ~ +10V
				Sz	N/A	Speed command is 0
S2	0	1	Internal parameter		P1-09	-60000 ~ +60000 r/min
S3	1	0			P1-10	
S4	1	1			P1-11	

- State of SPD0~1: 0: indicates OFF (Normally Open); 1: indicates ON (Normally Closed)
- When SPD0 and SPD1 are both = 0 (OFF), if the control mode of operation is Sz, then the speed command is 0. Therefore, if the users do not use analog voltage as speed command, the users can choose Sz mode and avoid the zero point drift problem of analog voltage signal. If the speed control mode is S mode, then the command is the analog voltage between V-REF and GND. The setting range of the input voltage is from -10V to +10V and the corresponding motor speed is adjustable (Please see parameter P1-40).
- When at least one of SPD0 and SPD1 is not 0 (OFF), the speed command is internal parameter (P1-09 to P1-11). The command is valid (enabled) after either SPD0 or SPD1 is changed.
- The range of internal parameters is within -60000 ~ +60000 r/min. Setting value = Range x Unit (0.1 r/min). For example, if P1-09 is set to +30000, the setting value = +30000 x 0.1 r/min = +3000 r/min.

The speed command that is described in this section not only can be taken as speed command in speed control mode (S or Sz mode) but also can be the speed limit input command in torque control mode (T or Tz mode).

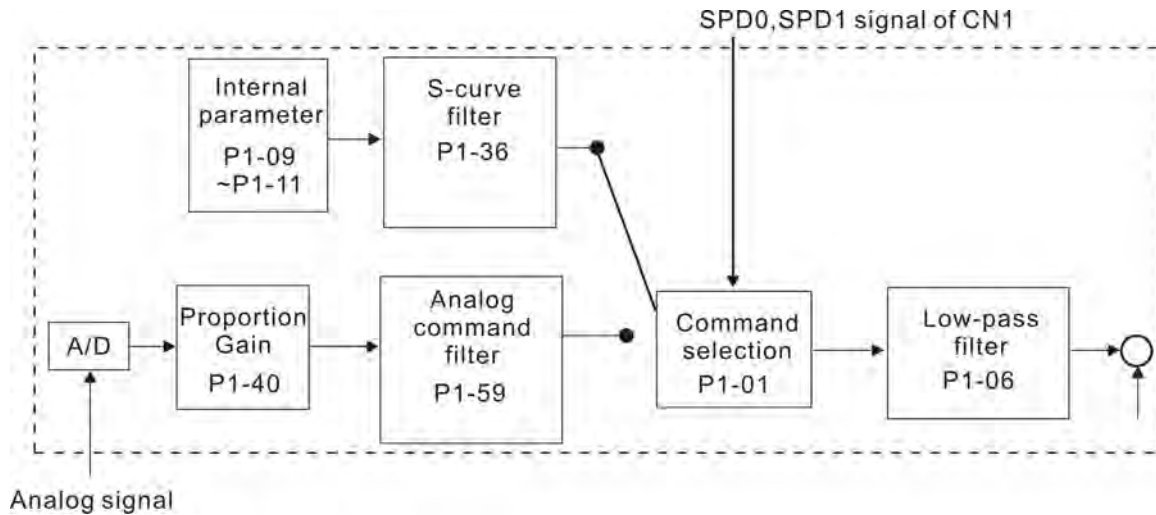
6.3.2 Structure of Speed Control Mode

Basic Structure:



In the figure above, the speed command processing is used to select the command source of speed control according to chapter 6.3.1, including proportional gain (P1-40) and S-curve filter smoothing strategy of speed control. The speed control block diagram is used to manage the gain parameters of the servo drive and calculate the current input provided to motor instantaneously. The resonance suppression block diagram is used to suppress the resonance of mechanical system.

The function and structure of speed command processing is shown as the figure below:

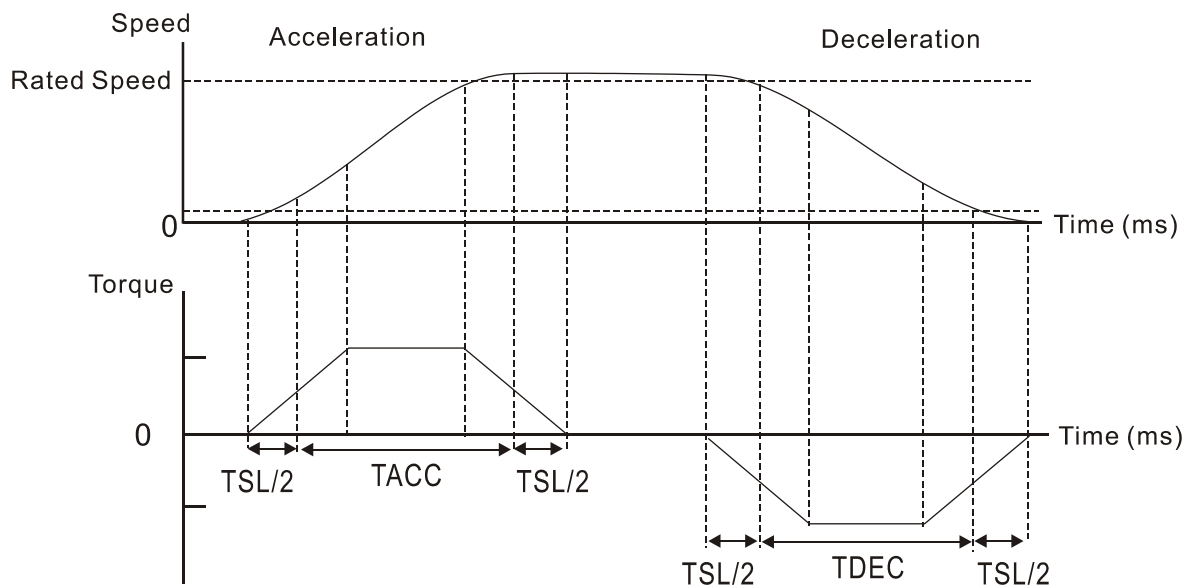


The command source is selected according to the state of SPD0, SPD1 and parameter P1-01 (S or Sz). Whenever the command signal needs to be more smoothly, we recommend the users to use S-curve and low-pass filter.

6.3.3 Smoothing Strategy of Speed Control Mode

S-curve Filter

The S-curve filter is a speed smoothing command which provides 3 steps accel / decel S-curve to smooth the speed command change of the motor during acceleration and deceleration. Using S-curve filter can let the servo motor run more smoothly in response to a sudden speed command change. Since the speed and acceleration curve are both continuous, in order to avoid the mechanical resonance and noise may occur due to a sudden speed command (differentiation of acceleration), using S-curve filter not only can improve the performance when servo motor accelerate or decelerate but also can make the motor run more smoothly. S-curve filter parameters include P1-34 Acceleration Time (TACC), P1-35 Deceleration Time (TDEC) and Accel /Decel S-curve (TSL), and the users can use these three parameters to improve the motor performance during acceleration, deceleration and operation. ASDA-A2 series servo drives also support the time calculation of completing speed command. T (ms) is the operation (running) time. S (r/min) is absolute speed command, i.e. the absolute value (the result) after starting speed subtracts the final speed.



S-curve characteristics and Time relationship

Relevant parameters:

P1 - 34	TACC	Acceleration Time	Address: 0144H, 0145H
----------------	-------------	--------------------------	------------------------------

Default: 200

Related Section: Section

6.3.3,

Applicable Control Mode: S

Unit: msec

Range: 1 ~ 65500

Data Size: 16-bit

Display Format: Decimal

Settings:

This parameter is used to determine the acceleration time to accelerate from 0 to its rated motor speed. The functions of parameters P1-34, P1-35 and P1-36 are each individual. When P1-36 is set to 0 (Disabled), the settings of P1-34, P1-35 are still effective. It indicates that the parameters P1-34 and P1-35 will not become disabled even when P1-36 is disabled.

Please note:

1. When the source of speed command is analog command, the maximum setting value of P1-36 is set to 0, the acceleration and deceleration function will be disabled.
2. When the source of speed command is analog command, the maximum setting value of P1-34 is limited to 20000 automatically.

P1 - 35	TDEC	Deceleration Time	Address: 0146H, 0147H
----------------	-------------	--------------------------	------------------------------

Default: 200

Related Section:

Applicable Control Mode: S

Section 6.3.3

Unit: msec

Range: 1 ~ 65500

Data Size: 16-bit

Display Format: Decimal

Settings:

This parameter is used to determine the acceleration time to accelerate from 0 to its rated motor speed. The functions of parameters P1-34, P1-35 and P1-36 are each individual. When P1-36 is set to 0 (Disabled), the settings of P1-34, P1-35 are still effective. It indicates that the parameters P1-34 and P1-35 will not become disabled even when P1-36 is disabled.

Please note:

1. When the source of speed command is analog command, the maximum setting value of P1-36 is set to 0, the acceleration and deceleration function will be disabled.
2. When the source of speed command is analog command, the maximum setting value of P1-35 is limited to 20000 automatically.

P1 - 36	TSL	Accel /Decel S-curve	Address: 0148H, 0149H
----------------	------------	-----------------------------	------------------------------

Default: 0

Related Section:

Unit: msec

Section 6.3.3

Applicable Control Mode: S, PR

Unit: msec

Range: 0 ~ 65500 (0: Disabled)

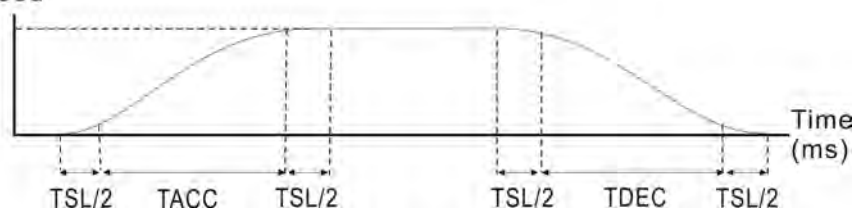
Data Size: 16-bit

Display Format: Decimal

Settings:

This parameter is used to make the motor run more smoothly when startup and windup. Using this parameter can improve the motor running stability.

Speed



TACC: P1-34, Acceleration time

TDEC: P1-35, Deceleration time

TSL: P1-36, Accel /Decel S-curve

Total acceleration time = TACC + TSL

Total deceleration time = TDEC + TSL

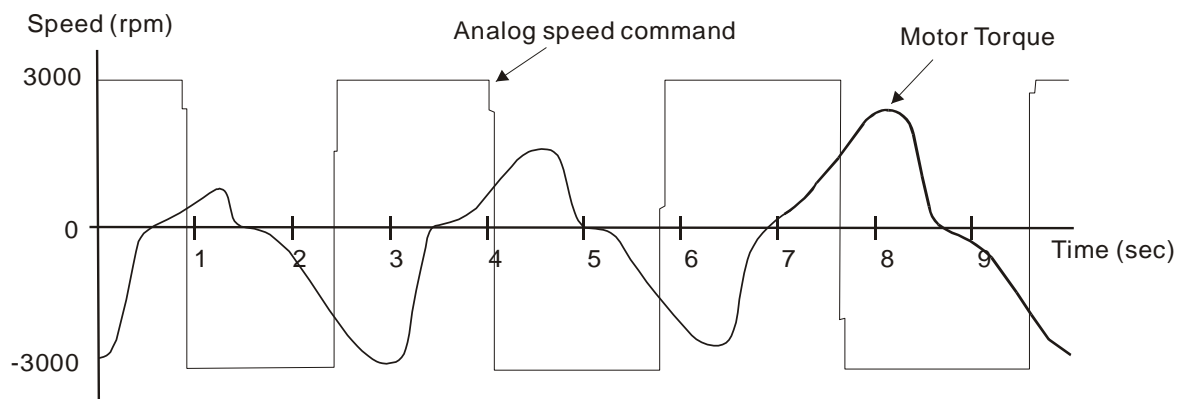
The functions of parameters P1-34, P1-35 and P1-36 are each individual. When P1-36 is set to 0 (Disabled), the settings of P1-34, P1-35 are still effective. It indicates that the parameters P1-34 and P1-35 will not become disabled even when P1-36 is disabled.

Please note:

1. When the source of speed command is analog command, the maximum setting value of P1-36 is set to 0, the acceleration and deceleration function will be disabled.
2. When the source of speed command is analog command, the maximum setting value of P1-36 is limited to 10000 automatically.
3. If the control of the servo motor is achieved via internal parameters, the command curve should be defined by the users.

Analog Speed Command S-curve Filter

ASDA-A2 series servo drives also provide Analog Speed Command S-curve Filter for the smoothing in response to a sudden analog input signal.



The analog speed command S-curve filter is for the smoothing of analog input signal and its function is the same as the S-curve filter. The speed and acceleration curve of analog speed command S-curve filter are both continuous. The above figure shows the curve of analog speed command S-curve filter and the users can see the ramp of speed command is different during acceleration and deceleration. Also, the users can see the difference of input command tracking and can adjust time setting by using parameter P1-34, P1-35, P1-36 to improve the actual motor performance according to actual condition.

Analog Speed Command Low-pass Filter

Analog Speed Command Low-pass Filter is used to eliminate high frequency response and electrical interference from an analog speed command and it is also with smoothing function.

Relevant parameters:

P1 - 06	SFLT	Accel / Decel Smooth Constant of Analog Speed Command (Low-pass Filter)	Address: 010CH, 010DH
----------------	-------------	--	------------------------------

Default: 0

Related Section:

Applicable Control Mode: S

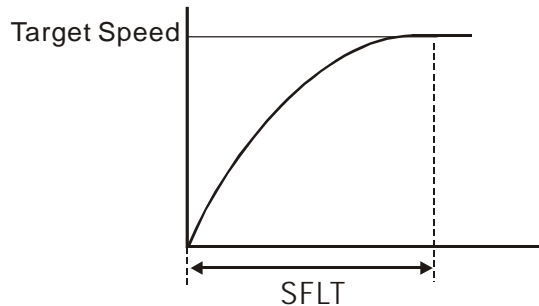
Section 6.3.3

Unit: msec

Range: 0 ~ 1000 (0: Disabled)

Data Size: 16-bit

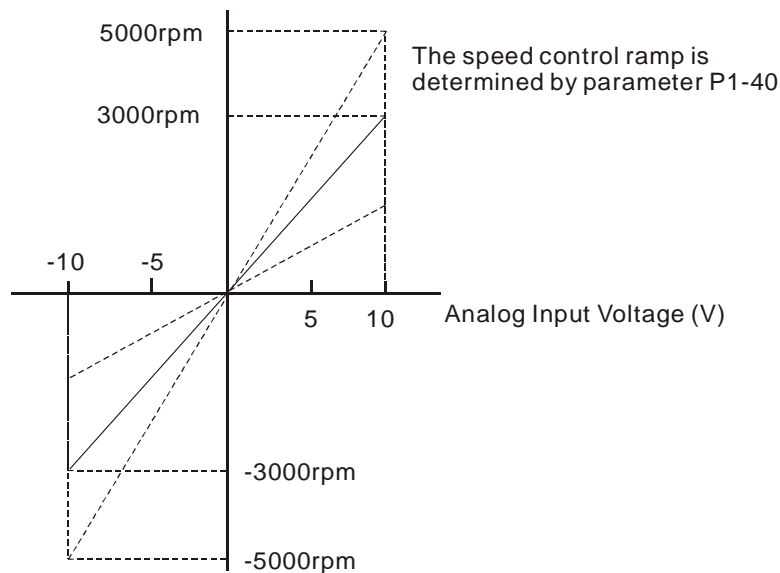
Display Format: Decimal



6.3.4 Analog Speed Input Scaling

The analog voltage between **V_REF** and **GND** determines the motor speed command.

Using with parameter P1-40 (Max. Analog Speed Command) can adjust the speed control ramp and its range.



Relevant parameters:

P1 - 40▲	VCM	Max. Analog Speed Command or Limit	Address: 0150H, 0151H
-----------------	------------	---	------------------------------

Default: rated speed

Related Section:

Applicable Control Mode: S, T

Section 6.3.4

Unit: r/min

Range: 0 ~ 10000

Data Size: 16-bit

Display Format: Decimal

Settings:

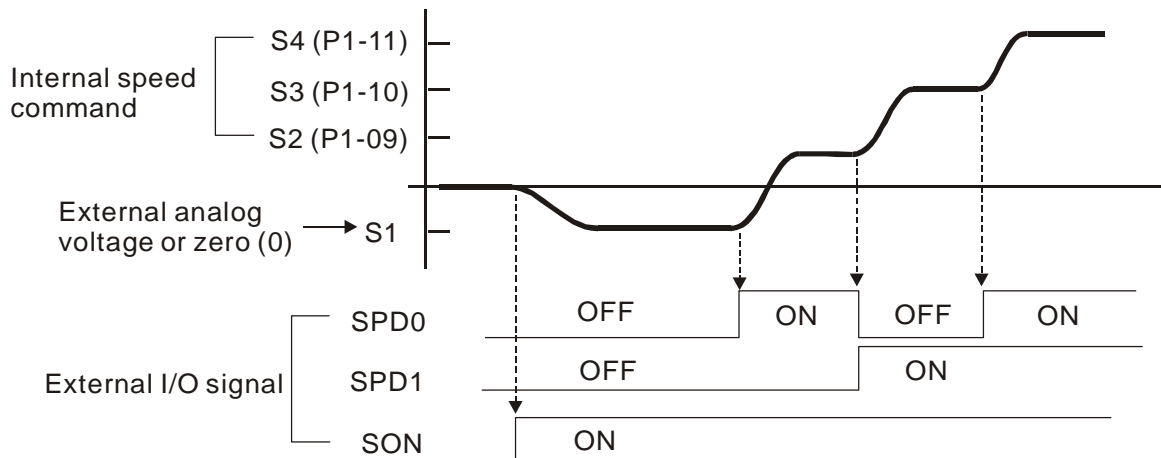
In **Speed mode**, this parameter is used to set the maximum analog speed command based on the maximum input voltage (10V).

In **Torque mode**, this parameter is used to set the maximum analog speed limit based on the maximum input voltage (10V).

For example, in speed mode, if P1-40 is set to 3000 and the input voltage is 10V, it indicates that the speed command is 3000 r/min. If P1-40 is set to 3000, but the input voltage is changed to 5V, then the speed command is changed to 1500 r/min.

$$\text{Speed Command / Limit} = \text{Input Voltage Value} \times \text{Setting value of P1-40} / 10$$

6.3.5 Timing Chart of Speed Control Mode

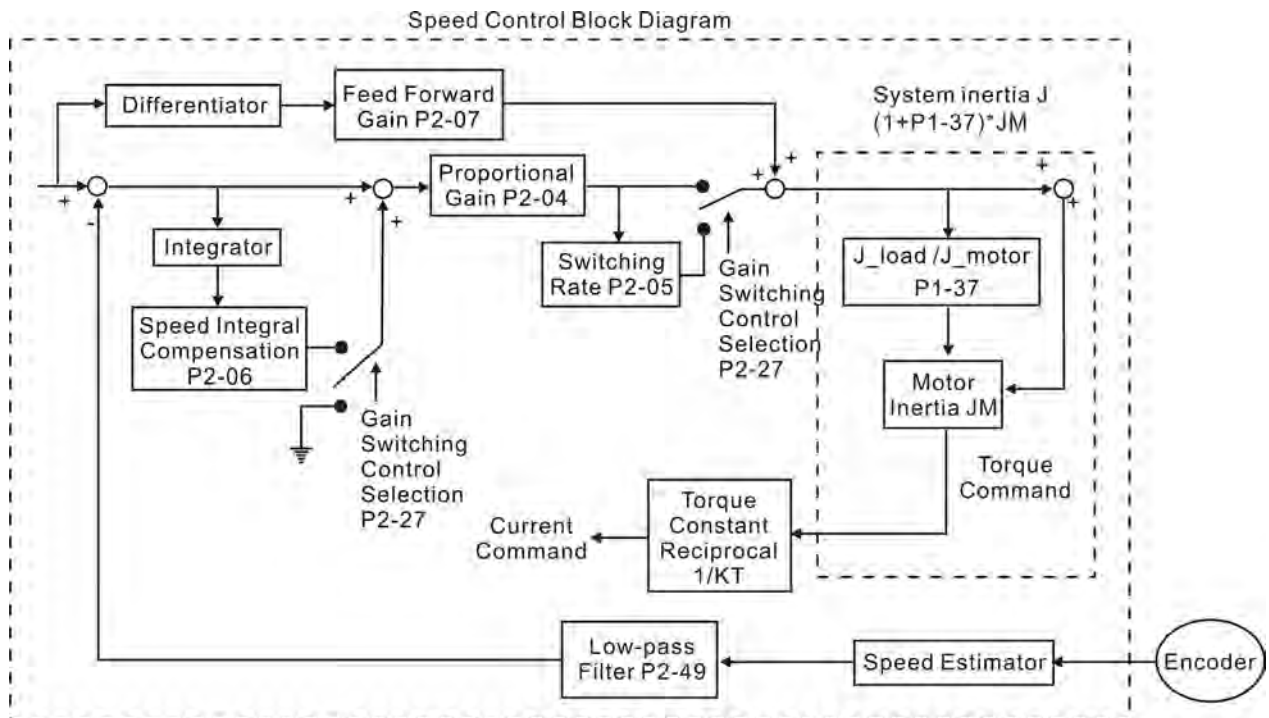


NOTE

- 1) OFF indicates normally open and ON indicates normally closed.
- 2) When speed control mode is Sz, the speed command S1=0; when speed control mode is S, the speed command S1 is external analog voltage input (Please refer to P1-01).
- 3) After Servo ON, the users can select command according to the state of SPD0~1.

6.3.6 Speed Loop Gain Adjustment

The function and structure of **speed control mode** is shown as the figure below:



There are two turning modes of gain adjustment: Manual and Auto modes. The gain of ASDA-A2 series servo drives can be adjusted by using any one of two tuning modes.

- **Manual Mode:** User-defined loop gain adjustment. When using this mode, all auto and auxiliary function will be disabled.
- **Auto Mode:** Continuous adjustment of loop gains according to measured inertia, with ten levels of system bandwidth. The parameter set by user is default value.

The mode of gain adjustment can be selected by parameter P2-32:

Relevant Parameter:

P2 - 32▲	AUT2	Tuning Mode Selection	Address: 0240H, 0241H
-----------------	-------------	------------------------------	------------------------------

Default: 0

Applicable Control Mode: ALL

Unit: N/A

Range: 0 ~ 2

Data Size: 16-bit

Display Format: Hexadecimal

Settings:

0: Manual mode

1: Auto Mode [Continuous adjustment]

2: Semi-Auto Mode [Non-continuous adjustment]

Related Section:

Section 5.6, Section 6.3.6

Explanation of manual mode:

1. When P2-32 is set to mode#0, the setting value of P2-00, P2-02, P2-04, P2-06, P2-07, P2-25 and P2-26 can be user-defined. When switching mode #1 or #2 to #0, the setting value of P2-00, P2-02, P2-04, P2-06, P2-07, P2-25 and P2-26 will change to the value that measured in #1 auto-tuning mode or #2 semi-auto tuning mode.

Explanation of auto-tuning mode:

The servo drive will continuously estimate the system inertia, save the measured load inertia value automatically and memorized in P1-37 every 30 minutes by referring to the frequency response settings of P2-31.

1. When switching mode #1 or #2 to #0, the servo drive will continuously estimate the system inertia, save the measured load inertia value automatically and memorized in P1-37. Then, set the corresponding parameters according to this measured load inertia value.
2. When switching mode#0 or #1 to #2, enter the appropriate load inertia value in P1-37.
3. When switching mode#1 to #0, the setting value of P2-00, P2-04 and P2-06 will change to the value that measured in #1 auto-tuning mode.

Explanation of semi-auto tuning mode:

1. When switching mode #2 to #0, the setting value of P2-00, P2-04, P2-06, P2-25 and P2-26 will change to the value that measured in #1 auto-tuning mode.
2. After the system inertia becomes stable (The display of P2-33 will show 1), it will stop estimating the system inertia, save the measured load inertia value automatically, and memorized in P1-37. However, when P2-32 is set to mode#1 or #2, the servo drive will continuously perform the adjustment for a period of time.
3. When the value of the system inertia becomes over high, the display of P2-33 will show 0 and the servo drive will start to adjust the load inertia value continuously.

Manual Mode

When Tuning Mode Settings of P2-32 is set to 0, the users can define the proportional speed loop gain (P2-04), speed integral gain (P2-06) feed forward gain (P2-07) and ratio of load inertia to servo motor Inertia (1-37). Please refer to the following description:

- Proportional gain: Adjust this gain can increase the position loop responsiveness.
- Integral gain: Adjust this gain can enhance the low-frequency stiffness of speed loop and eliminate the steady error. Also, reduce the value of phase margin. Over high integral gain will result in the unstable servo system.
- Feed forward gain: Adjust this gain can decrease the phase delay error

Relevant parameters:

P2 - 04	KVP	Proportional Speed Loop Gain	Address: 0208H, 0209H
----------------	------------	-------------------------------------	------------------------------

Default: 500

Related Section:

Applicable Control Mode: ALL

Section 6.3.6

Unit: rad/s

Range: 0 ~ 8191

Data Size: 16-bit

Display Format: Decimal

Settings:

This parameter is used to set the speed loop gain. When the value of proportional speed loop gain is increased, it can expedite speed loop response. However, if the setting value is over high, it may generate vibration or noise.

P2 - 06	KVI	Speed Integral Compensation	Address: 020CH, 020DH
----------------	------------	------------------------------------	------------------------------

Default: 100

Related Section:

Applicable Control Mode: ALL

Section 6.3.6

Unit: rad/s

Range: 0 ~ 1023

Data Size: 16-bit

Display Format: Decimal

Settings:

This parameter is used to set the integral time of speed loop. When the value of speed integral compensation is increased, it can improve the speed response ability and decrease the speed control deviation. However, if the setting value is over high, it may generate vibration or noise.

P2 - 07	KVF	Speed Feed Forward Gain	Address: 020EH, 020FH
----------------	------------	--------------------------------	------------------------------

Default: 0

Related Section:

Applicable Control Mode: ALL

Section 6.3.6

Unit: %

Range: 0 ~ 100

Data Size: 16-bit

Display Format: Decimal

Settings:

This parameter is used to set the feed forward gain when executing speed control command.

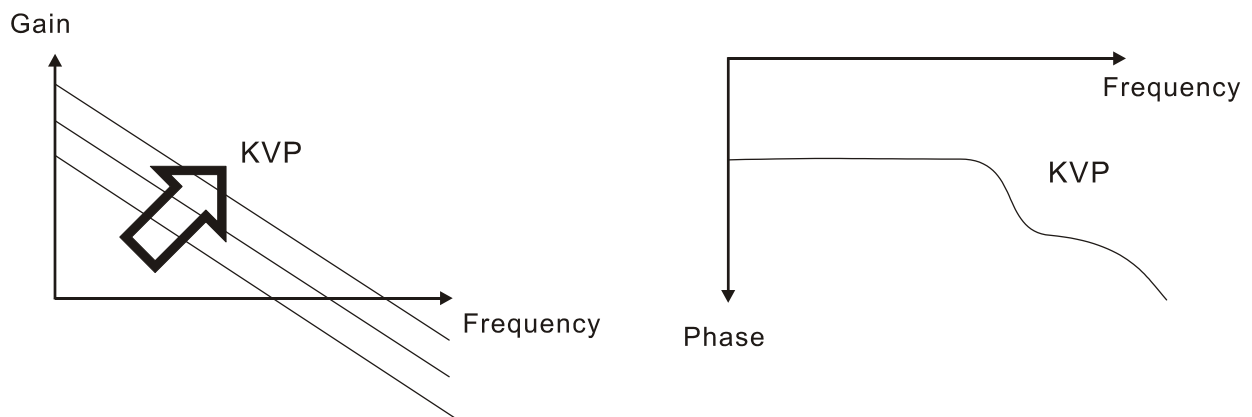
When using speed smooth command, increase gain can improve speed track deviation.

When not using speed smooth command, decrease gain can improve the resonance condition of mechanical system.

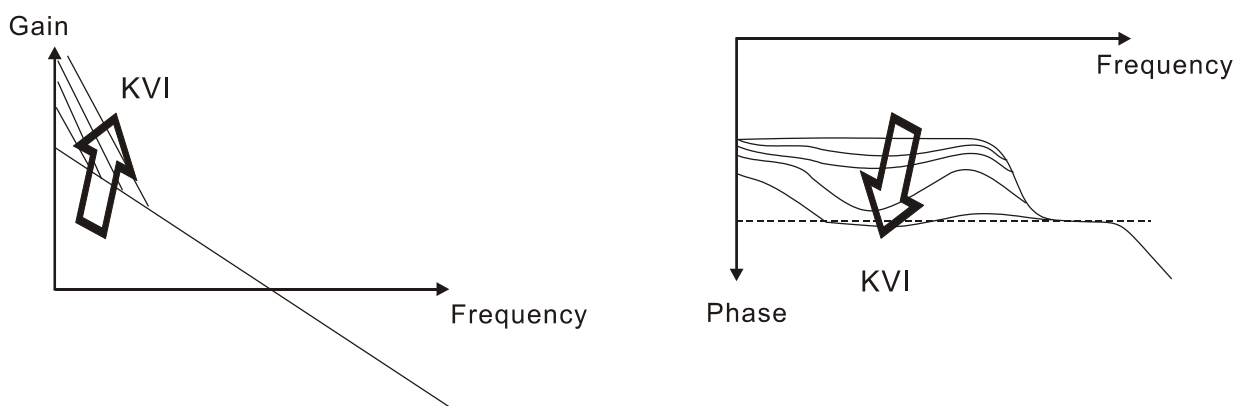
In theory, stepping response can be used to explain proportional gain (KVP), integral gain (KVI) and feed forward gain (KVF). Now we use frequency area and time area respectively to explain the logic.

Frequency Domain

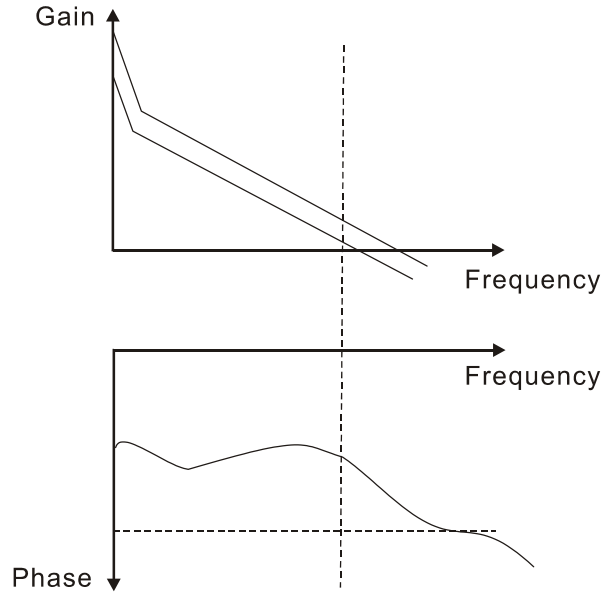
STEP 1: Set the value of KVI=0, the value of KVF=0 and adjust the value of KVP.



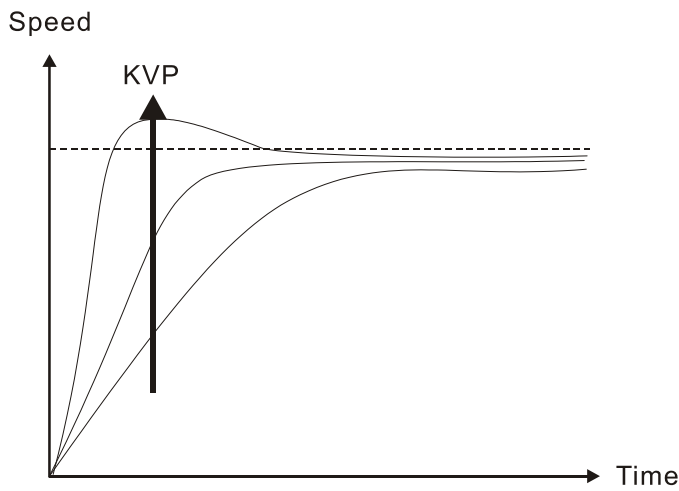
STEP 2 : Fix the value of KVP and adjust the value of KVI.



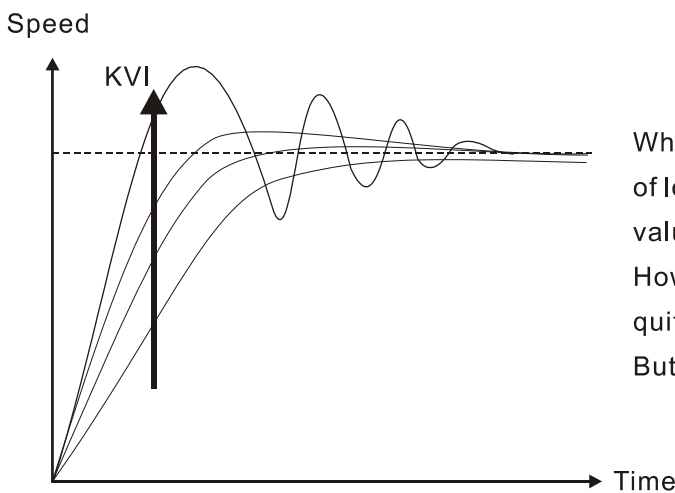
STEP 3 : Select the value of KVI, if the value of phase margin is too small, re-adjust the value of KVP again to obtain the value, 45deg of phase margin.



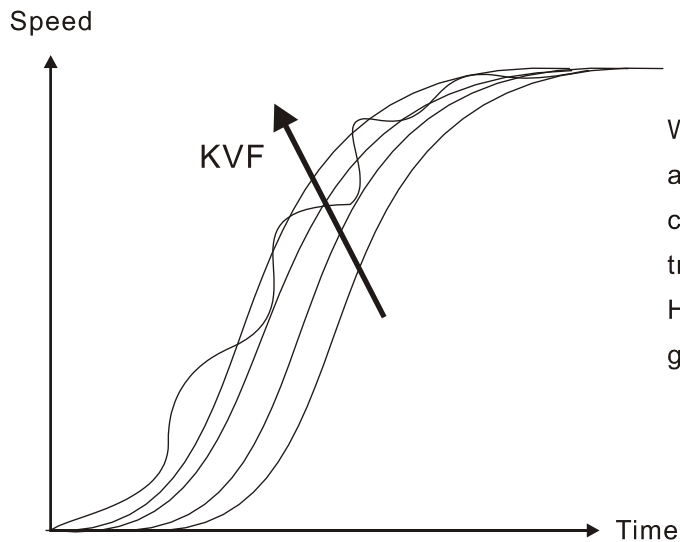
Time Domain



When the value of KVP is greater, the value of the responsiveness is also greater and the raising time is shorter. However, when the value of phase margin is over low, it is not helpful to steady error. But it is helpful to dynamic tracking error.



When the value of KVI is greater, the value of low-frequency gain is also greater and the value of steady error is nearly zero (0). However, the value of phase margin will reduce quite substantially. It is helpful to steady error. But it is not helpful to dynamic tracking error.

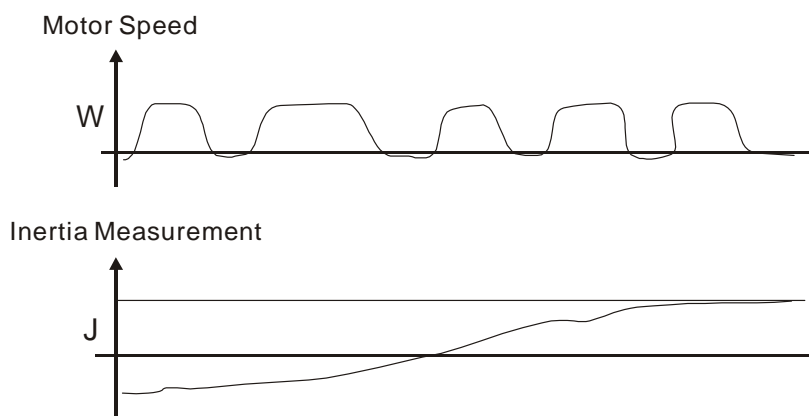


When the value of KVF is nearly to 1 and the forward compensation is more complete, then the value of dynamic tracking error will become very small. However, when the value of KVF is too great, it may cause vibration.

In general, the equipment, such as spectrum analyzer is needed and used to analyze when using frequency domain method and the users also should have this kind of analysis technology. However, when using time domain method, the users only need to prepare an oscilloscope. Therefore, the general users usually use time domain method with the analog DI/DO terminal provided by the servo drive to adjust what is called as PI (Proportional and Integral) type controller. As for the performance of torque shaft load, input command tracking and torque shaft load have the same responsiveness when using frequency domain method and time domain method. The users can reduce the responsiveness of input command tracking by using input command low-pass filter.

Auto Mode (Continuous adjustment)

This Auto Mode provides continuous adjustment of loop gains according to measured inertia automatically. It is suitable when the load inertia is fixed or the load inertia change is small and is not suitable for wide range of load inertia change. The period of adjustment time is different depending on the acceleration and deceleration of servo motor. To change the stiffness and responsiveness, please use parameter P2-31.



6.3.7 Resonance Suppression

The resonance of mechanical system may occur due to excessive system stiffness or frequency response. However, this kind of resonance condition can be improved, suppressed, even can be eliminated by using low-pass filter (parameter P2-25) and notch filter (parameter P2-23, P2-24) without changing control parameter.

Relevant parameters:

P2 - 23	NCF1	Notch Filter 1 (Resonance Suppression)	Address: 022EH, 022FH
----------------	-------------	---	------------------------------

Default: 1000

Related Section:

Applicable Control Mode: ALL

Section 6.3.7

Unit: Hz

Range: 50 ~ 1000

Data Size: 16-bit

Display Format: Decimal

Settings:

This parameter is used to set first resonance frequency of mechanical system. It can be used to suppress the resonance of mechanical system and reduce the vibration of mechanical system.

If P2-24 is set to 0, this parameter is disabled.

The parameters P2-23 and P2-24 are the first group of notch filter parameters and the parameters P2-43 and P2-44 are the second group of notch filter parameters.

P2 - 24	DPH1	Notch Filter Attenuation Rate 1 (Resonance Suppression)	Address: 0230H, 0231H
----------------	-------------	--	------------------------------

Default: 0

Related Section:

Applicable Control Mode: ALL

Section 6.3.7

Unit: dB

Range: 0 ~ 32

Data Size: 16-bit

Display Format: Decimal

Settings:

This parameter is used to set magnitude of the resonance suppression that is set by parameter P2-23. If P2-24 is set to 0, the parameters P2-23 and P2-24 are both disabled.

The parameters P2-23 and P2-24 are the first group of notch filter parameters and the parameters P2-43 and P2-44 are the second group of notch filter parameters.

P2 - 43	NCF2	Notch Filter 2 (Resonance Suppression)	Address: 0256H, 0257H
----------------	-------------	---	------------------------------

Default: 1000

Related Section:

Applicable Control Mode: ALL

Section 6.3.7

Unit: Hz

Range: 50 ~ 2000

Data Size: 16-bit

Display Format: Decimal

Settings:

This parameter is used to set second resonance frequency of mechanical system. It can be used to suppress the resonance of mechanical system and reduce the vibration of mechanical system.

If P2-43 is set to 0, this parameter is disabled.

The parameters P2-23 and P2-24 are the first group of notch filter parameters and the parameters P2-43 and P2-44 are the second group of notch filter parameters.

P2 - 44	DPH2	Notch Filter Attenuation Rate 2 (Resonance Suppression)	Address: 0258H, 0259H
----------------	-------------	--	------------------------------

Default: 0

Related Section:

Applicable Control Mode: ALL

Section 6.3.7

Unit: dB

Range: 0 ~ 32

Data Size: 16-bit

Display Format: Decimal

Settings:

This parameter is used to set magnitude of the resonance suppression that is set by parameter P2-43. If P2-44 is set to 0, the parameters P2-43 and P2-44 are both disabled.

P2 - 45	NCF3	Notch Filter 3 (Resonance Suppression)	Address: 025AH, 025BH
----------------	-------------	---	------------------------------

Default: 1000

Related Section:

Applicable Control Mode: ALL

Section 6.3.7

Unit: Hz

Range: 50 ~ 2000

Data Size: 16-bit

Display Format: Decimal

Settings:

This parameter is used to set third resonance frequency of mechanical system. It can be used to suppress the resonance of mechanical system and reduce the vibration of mechanical system.

If P2-45 is set to 0, this parameter is disabled.

P2 - 46	DPH3	Notch Filter Attenuation Rate 3 (Resonance Suppression)	Address: 025CH, 025DH
----------------	-------------	--	------------------------------

Default: 0

Related Section:

Applicable Control Mode: ALL

Section 6.3.7

Unit: dB

Range: 0 ~ 32

Data Size: 16-bit

Display Format: Decimal

Settings:

This parameter is used to set magnitude of the resonance suppression that is set by parameter P2-45. If P2-46 is set to 0, the parameters P2-45 and P2-46 are both disabled.

P2 - 25	NLP	Low-pass Filter Time Constant (Resonance Suppression)	Address: 0232H, 0233H
----------------	------------	--	------------------------------

Default: 2 (1kW and below models) or
5 (other models)

Related Section:

Section 6.3.7

Applicable Control Mode: ALL

Unit: 0.1 msec

Range: 0 ~ 1000

Data Size: 16-bit

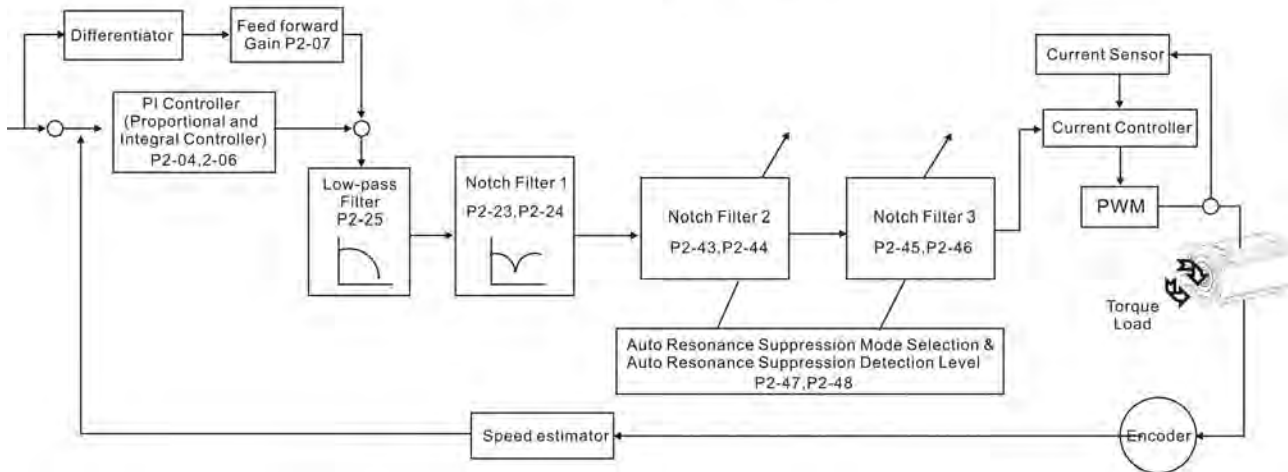
Display Format: Decimal

Settings:

This parameter is used to set low-pass filter time constant of resonance suppression.

If P2-25 is set to 0, this parameter is disabled.

Speed Control Block Diagram



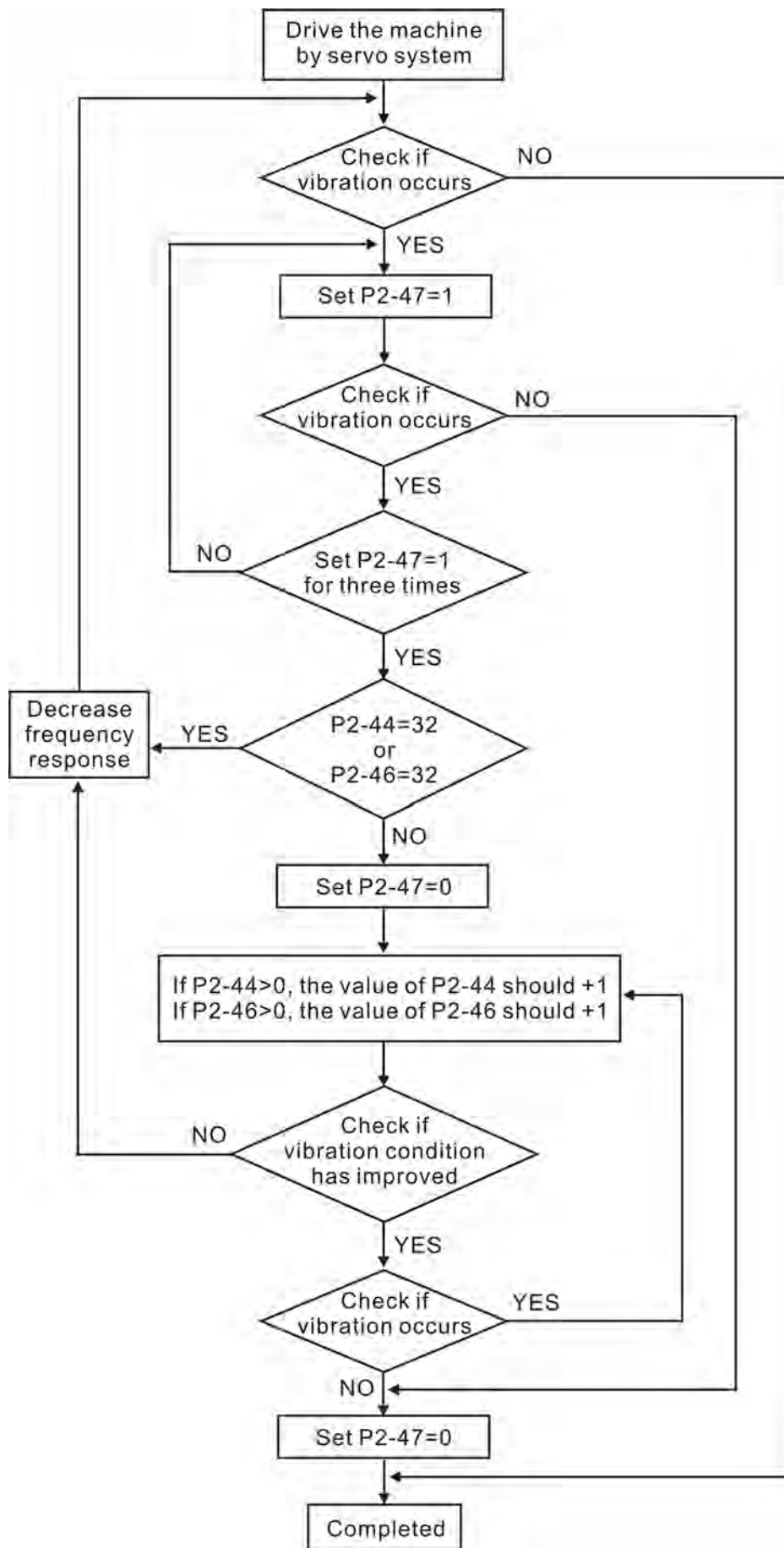
There are two groups of notch filters provided by ASDA-A2 series. The first group of notch filter is P2-43 and P2-44, and the second group of notch filter is P2-45 and P2-46. When there is resonance, please set P2-47 to 1 or 2 (Auto mode), and then the servo drive will find resonance frequency and suppress the resonance automatically. After suppressing the resonance point, the system will memorize the notch filter frequency into P2-43 and P-45, and memorize the notch filter attenuation rate into P2-44 and P2-46.

When P2-47 is set to 1, the resonance suppression will be enabled automatically. After the mechanical system becomes stable (approximate 20 minutes), the setting value of P2-47 will return to 0 (Disable auto resonance suppression function). When P2-47 is set to 2, the system will find the resonance point continuously even after the mechanical system becomes stable.

When P2-47 is set to 1 or 2, if the resonance conditions can not be eliminated, we recommend the users to check the settings of P2-44 and P2-46. If either of the setting value of P2-44 and P2-46 is set to 32, please decrease the speed frequency response and estimate the resonance point again. If the resonance conditions can not be eliminated when the setting values of P2-44 and P2-46 are both less than 32, please set P2-47 to 0 first, and increase the setting value of P2-44 and P2-46 manually. If the resonance exists still after increasing the setting value of P2-44 and P2-46, please decrease the value of speed frequency response again and then use the resonance suppression function again.

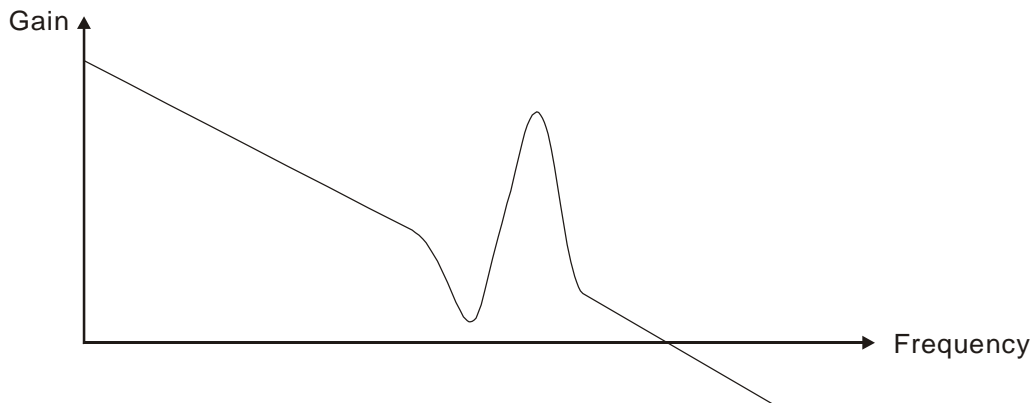
When increasing the setting value of P2-44 and P2-46 manually, ensure to pay close attention on the setting value of P2-44 and P2-46. If the value of P2-44 and P2-46 is greater than 0, it indicates that the corresponding resonance frequency of P2-43 and P2-45 is found through auto resonance suppression function. If the value of P2-44 and P2-46 is equal to 0, it indicates that the value of P2-43 and P2-45 will be the default value 1000 and this is not the frequency found by auto resonance suppression function. At this time, if the users increase the value of notch filter attenuation rate which does not exist, the performance of the current mechanical system may deteriorate.

Settings of P2-47		
Current Value	Desired Value	Function
0	1	Clear the setting value of P2-43 ~ P2-46 and enable auto resonance suppression function.
0	2	Clear the setting value of P2-43 ~ P2-46 and enable auto resonance suppression function.
1	0	Save the setting value of P2-43 ~ P2-46 and disable auto resonance suppression function.
1	1	Clear the setting value of P2-43 ~ P2-46 and enable auto resonance suppression function.
1	2	Do not clear the setting value of P2-43 ~ P2-46 and enable auto resonance suppression function continuously.
2	0	Save the setting value of P2-43 ~ P2-46 and disable auto resonance suppression function.
2	1	Clear the setting value of P2-43 ~ P2-46 and enable auto resonance suppression function.
2	2	Do not clear the setting value of P2-43 ~ P2-46 and enable auto resonance suppression function continuously.

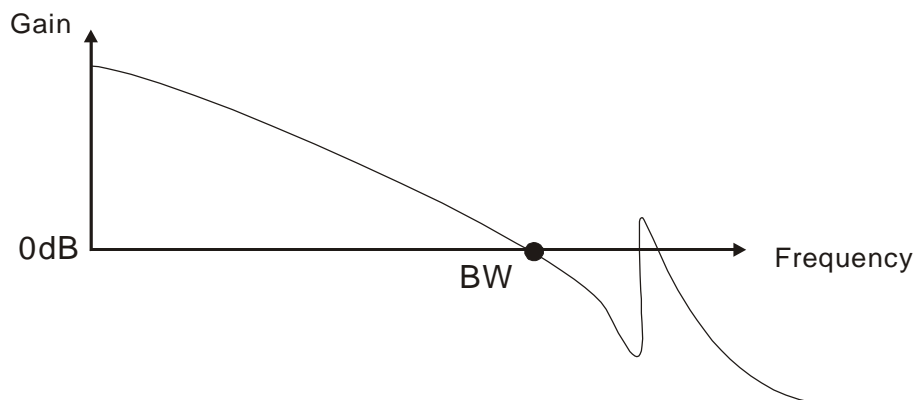


Low-pass filter

Please use parameter P2-25. The figure below shows the resonant open-loop gain.



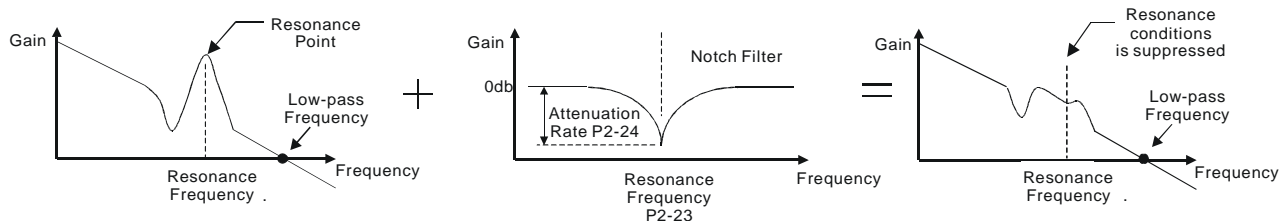
When the low-pass filter (parameter P2-25) is adjusted from 0 to high value, the value of Low-pass frequency (BW) will become smaller (see the figure below). The resonant condition is improved and the frequency response and phase margin will also decrease.

**Notch Filter**

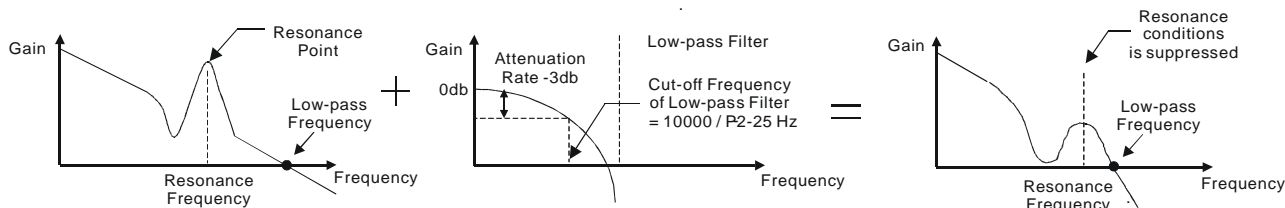
Usually, if the users know the resonance frequency, we recommend the users can eliminate the resonance conditions directly by using notch filter (parameter P2-23, P2-24). However, the range of frequency setting is from 50 to 1000Hz only and the range of resonant attenuation is 0~32 dB only. Therefore, if the resonant frequency is out of this range, we recommend the users to use low-pass filter (parameter P2-25) to improve resonant condition.

Please refer to the following figures and explanation to know how to use notch filter and low-pass filter to improve resonant condition.

Use Notch Filter to suppress resonance



Use Low-pass Filter to suppress resonance



When the low-pass filter (parameter P2-25) is adjusted from 0 to high value, the value of Low-pass frequency will become smaller (see the figure on page 6-26). The resonant condition is improved but the frequency response and phase margin will also decrease and the system may become unstable. Therefore, if the users know the resonance frequency, the users can eliminate the resonance conditions directly by using notch filter (parameter P2-23, P2-24). Usually, if the resonant frequency can be recognized, we recommend the users can directly use notch filter (parameter P2-23, P2-24) to eliminate the resonance. However, if the resonant frequency will drift or drift out of the notch filter range, we recommend the users not to use notch filter and use low-pass filter to improve resonant conditions.

6.4 Torque Control Mode

The torque control mode (T or Tz) is usually used on the applications of torque control, such as printing machine, spinning machine, twister, etc. Delta ASDA-A2 series servo drives support two kinds of command sources in torque control mode. One is external analog signal and the other is internal parameter. The external analog signal is from external voltage input and it can control the torque of servo motor. The internal parameters are from P1-12 to P1-14 which are used to be the torque command in torque control mode.

6.4.1 Command Source of Torque Control Mode

Torque command Sources:

- 1) External analog signal: External analog voltage input, -10V to +10V
- 2) Internal parameter: P1-12 to P1-14

The command source selection is determined by the DI signal of CN1 connector.

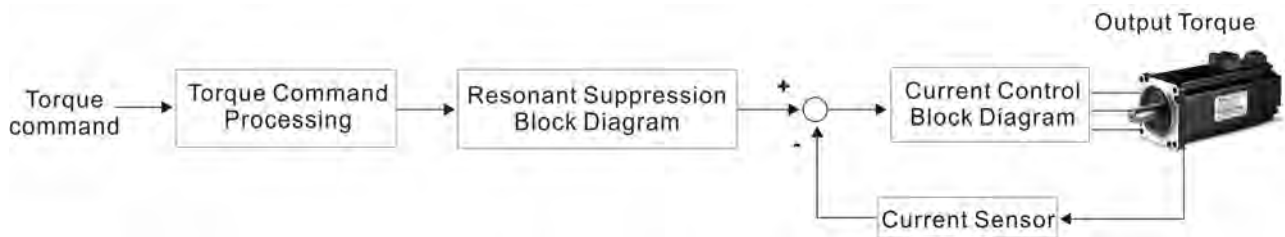
Torque Command	DI signal of CN1		Command Source		Content	Range	
	TCM1	TCM0					
T1	0	0	Mode	T	External analog signal	Voltage between T-REF-GND	-10V ~ +10V
				Tz	None	Torque command is 0	0
T2	0	1	Internal parameter		P1-12	-300% ~ 300%	
T3	1	0			P1-13		
T4	1	1			P1-14		

- State of TCM0~1: 0: indicates OFF (Normally Open); 1: indicates ON (Normally Closed)
- When TCM0 and TCM1 are both 0 (OFF), if the control mode of operation is Tz, then the command is 0. Therefore, if the users do not use analog voltage as torque command, the users can choose Tz mode to operation torque control to avoid the zero point drift problem of analog voltage. If the control mode of operation is T, then the command is the analog voltage between T-REF and GND. The setting range of the input voltage is from -10V to +10V and the corresponding torque is adjustable (see parameter P1-41).
- When at least one of TCM0 and TCM1 is not 0 (OFF), the torque command is internal parameter. The command is valid (enabled) after either TCM0 or TCM1 is changed.

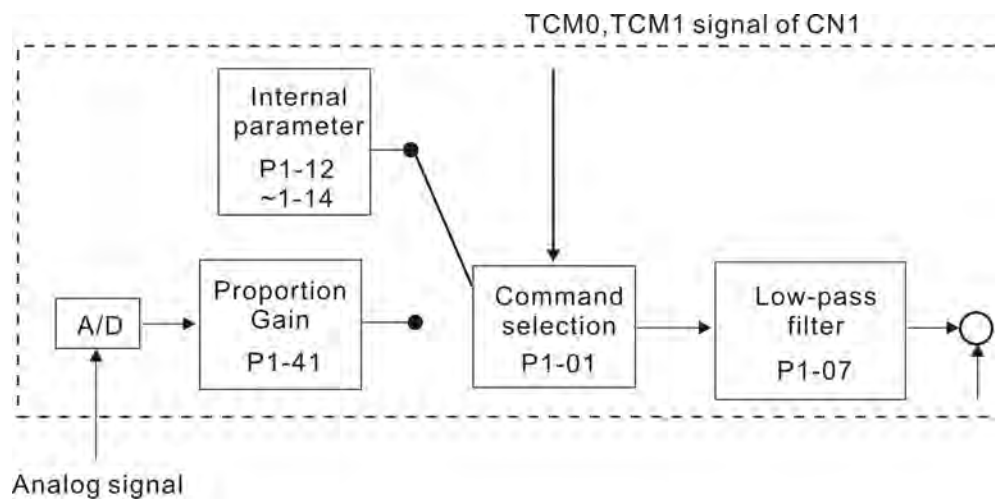
The torque command that is described in this section not only can be taken as torque command in torque control mode (T or Tz mode) but also can be the torque limit input command in position mode (P mode) and speed control mode (S or Sz mode).

6.4.2 Structure of Torque Control Mode

Basic Structure:



The torque command processing is used to select the command source of torque control according to chapter 6.4.1, including max. analog torque command (parameter P1-41) and smoothing strategy of torque control mode. The current control block diagram is used to manage the gain parameters of the servo drive and calculate the current input provided to motor instantaneously. As the current control block diagram is too complicated, setting the parameters of current control block diagram is not allowed. The function and structure of torque command processing is shown as the figure below:



The command source is selected according to the state of TCM0, TCM1 and parameter P1-01 (T or Tz). Whenever the command signal needs to be more smoothly, we recommend the users to use proportional gain (scalar) and low-pass filter to adjust torque.

6.4.3 Smoothing Strategy of Torque Control Mode

Relevant parameters:

P1 - 07	TFLT	Smooth Constant of Analog Torque Command (Low-pass Filter)	Address: 010EH, 010FH
----------------	-------------	---	------------------------------

Default: 0

Related Section:

Applicable Control Mode: T

Section 6.4.3

Unit: msec

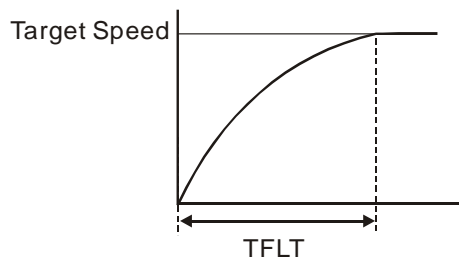
Range: 0 ~ 1000 (0: Disabled)

Data Size: 16-bit

Display Format: Decimal

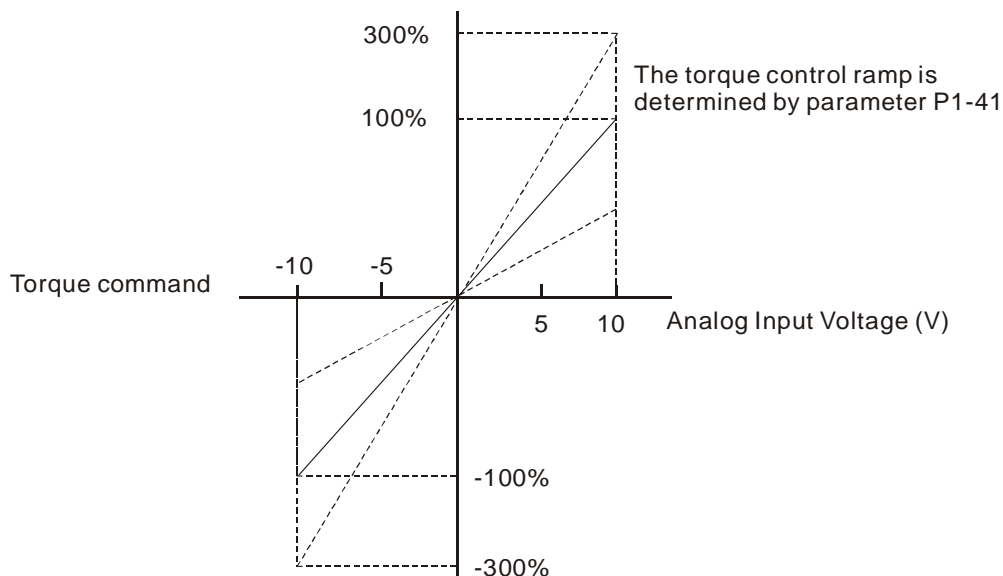
**NOTE**

- 1) If the setting value of parameter P1-07 is set to 0, it indicates the function of this parameter is disabled and the command is just By-Pass.



6.4.4 Analog Torque Input Scaling

The analog voltage between T_REF and GND controls the motor torque command. Using with parameter P1-41 can adjust the torque control ramp and its range.



Relevant parameters:

P1 - 41 ▲	TCM	Max. Analog Torque Command or Limit	Address: 0152H, 0153H
------------------	------------	--	------------------------------

Default: 100

Related Section:

Applicable Control Mode: ALL

Section 6.4.4

Unit: %

Range: 0 ~ 1000

Data Size: 16-bit

Display Format: Decimal

Settings:

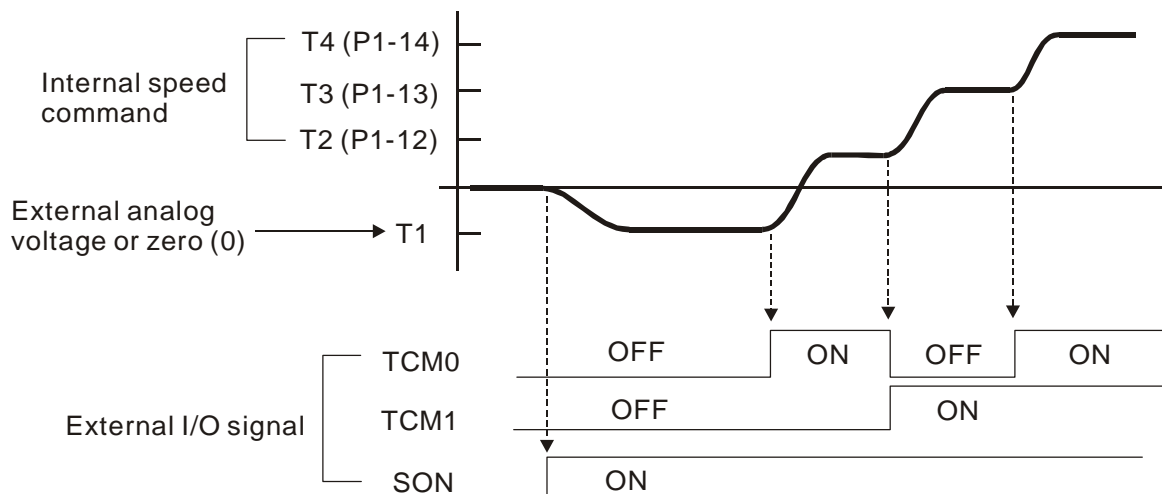
In **Torque mode**, this parameter is used to set the maximum analog torque command based on the maximum input voltage (10V).

In **Position (PT, PR)** and **Speed mode**, this parameter is used to set the maximum analog torque limit based on the maximum input voltage (10V).

For example, in torque mode, if P1-41 is set to 100 and the input voltage is 10V, it indicates that the torque command is 100% rated torque. If P1-41 is set to 100, but the input voltage is changed to 5V, then the torque command is changed to 50% rated torque.

$$\text{Torque Command / Limit} = \text{Input Voltage Value} \times \text{Setting value of P1-41} / 10$$

6.4.5 Timing Chart of Torque Control Mode



NOTE

- 1) OFF indicates normally open and ON indicates normally closed.
- 2) When torque control mode is Tz, the torque command T1=0; when torque control mode is T, the speed command T1 is external analog voltage input (Please refer to P1-01).
- 3) After Servo ON, the users can select command according to the state of TCM0~1.

6.5 Control Modes Selection

Except signal control mode operation, ASDA-A2 series servo drives also provide many dual and multiple modes for the users to select.

- 1) Speed / Position mode selection: PT-S, PR-S, PT-PR
- 2) Speed / Torque mode selection: S-T
- 3) Torque / Position mode selection: PT-T, PR-T
- 4) Position / Speed multiple mode selection: PT-PR-S
- 5) Position / Torque multiple mode selection: PT-PR-T

Mode	Name	Code	Description
Dual Mode	PT-S	06	Either PT or S control mode can be selected via the Digital Inputs (DI)
	PT-T	07	Either PT or T control mode can be selected via the Digital Inputs (DI)
	PR-S	08	Either PR or S control mode can be selected via the Digital Inputs (DI)
	PR-T	09	Either PR or T control mode can be selected via the Digital Inputs (DI)
	S-T	0A	Either S or T control mode can be selected via the Digital Inputs (DI)
	PT-PR	0D	Either PT or PR control mode can be selected via the Digital Inputs (DI).
Multiple Mode	PT-PR-S	0E	Either PT or PR or S control mode can be selected via the Digital Inputs (DI).
	PT-PR-T	0F	Either PT or PR or T control mode can be selected via the Digital Inputs (DI).

Sz and Tz mode selection is not provided. In order to avoid using too much DI inputs, we recommend that the users can use external analog signal as input command in speed and torque mode to reduce the use of DI inputs (SPD0~1 or TCM0~1). In position mode, we recommend that the users can use PT mode to input pulse to reduce the use of DI inputs (POS0~5).

Please refer to table 3.B and table 3.C in section 3.3.2 to see the default pin number of DI/DO signal.

6.5.1 Speed / Position Control Mode Selection

PT-S Mode / PR-S Mode:

The command source of PT-S mode is from external input pulse. The command source of PR-S mode is from internal parameters (P6-00 to P7-27). The speed command can be the external analog voltage or internal parameters (P1-09 to P1-11). The speed and position mode switching is controlled by the S-P signal. The selection will be more complicated when the position of PR-S mode and speed command are both selected through DI signal. The timing chart of speed / position control mode selection is shown as the figure below:

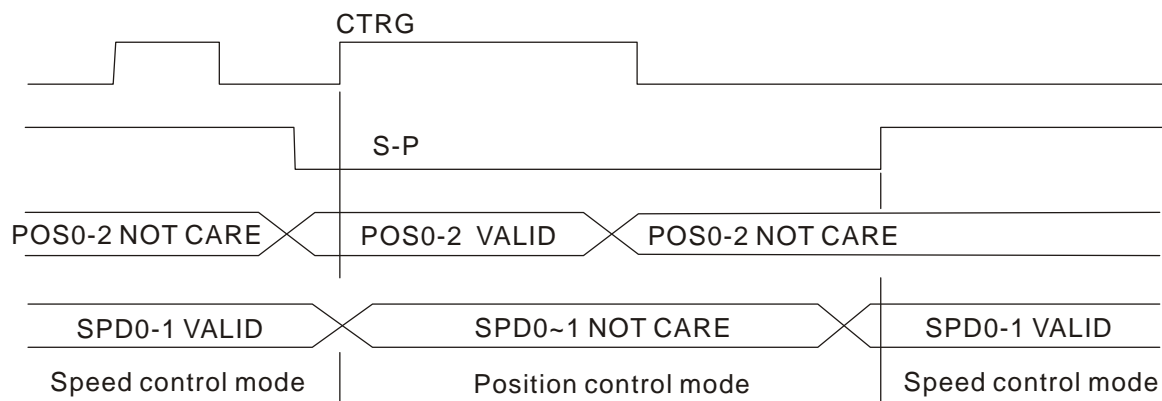


Figure 1. : Speed / Position Control Mode Selection

In speed mode (when S-P is ON), speed command is selected by SPD0~1 and CTRG is disabled at this time. When switching to the position mode (when S-P is OFF), the position command is not determined (it needs to wait that CTRG is on the rising edge), so the motor stop running. Once CTRG is on the rising edge, position command will be selected according to POS0~5 and the motor will immediately move to the determined position. After S-P is ON, it will immediately return to speed mode.

For the relationship between DI signal and selected command in each mode, please refer to the introduction of single mode.

6.5.2 Speed / Torque Control Mode Selection

S-T Mode:

The speed command can be the external analog voltage or internal parameters (P1-09 to P1-11) and SPD0~1 is used to select speed command. The same as speed command, the torque command can be the external analog voltage or internal parameters (P1-12 to P1-14) and TCM0~1 is used to select torque command. The speed and torque mode switching is controlled by the S-T signal.

The timing chart of speed / torque control mode selection is shown as the figure below:

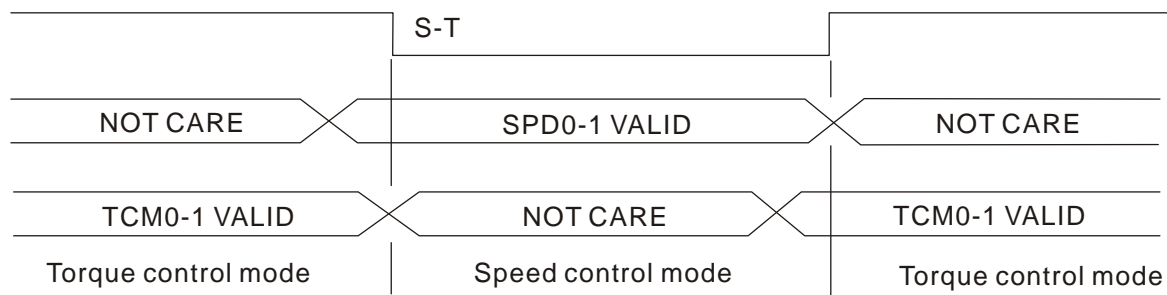


Figure 2. : Speed / Torque Control Mode Selection

In torque mode (when S-T is ON), torque command is selected by TCM0~1. When switching to the speed mode (when S-T is OFF), the speed command is selected by SPD0~1, and then the motor will immediately rotate following the command. After S-T is ON again, it will immediately return to torque mode.

6.5.3 Torque / Position Control Mode Selection

PT-T Mode / PR-T Mode:

The command source of PT-T mode is from external input pulse. The command source of PR-T mode is from internal parameters (P6-00 to P7-27). The torque command can be the external input pulse or internal parameters (P1-12 to P1-14). The torque and position mode switching is controlled by T-P signal. The selection will be more complicated when the position of PR-T mode and torque command are both selected through DI signal.

The timing chart of speed / position control mode selection is shown as the figure below:

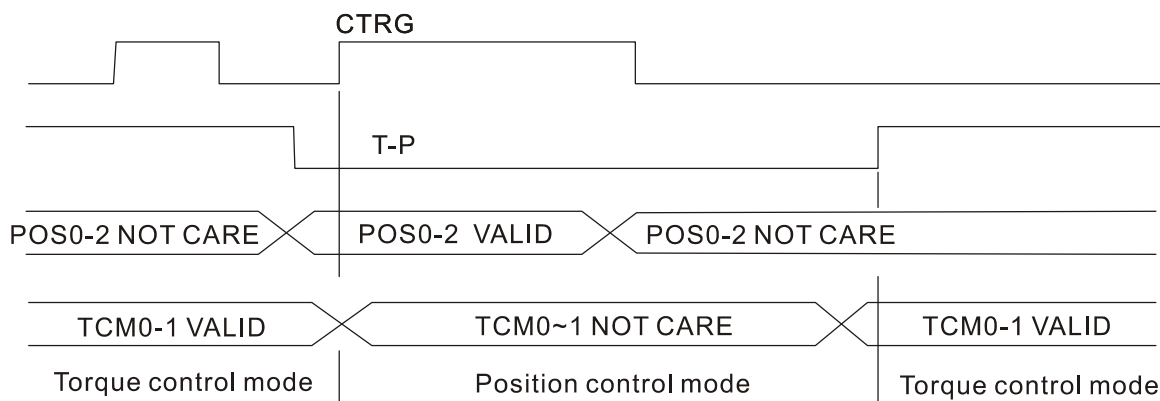


Figure 3. : Torque / Position Control Mode Selection

In torque mode (when T-P is ON), torque command is selected by TCM0~1 and CTRG is disabled at this time. When switching to the position mode (when T-P is OFF), the position command is not determined (it needs to wait that CTRG is on the rising edge), so the motor stop running. Once CTRG is on the rising edge, position command will be selected according to POS0~5 and the motor will immediately move to the determined position. After T-P is ON, it will immediately return to torque mode.

For the relationship between DI signal and selected command in each mode, please refer to the introduction of single mode.

6.6 Others

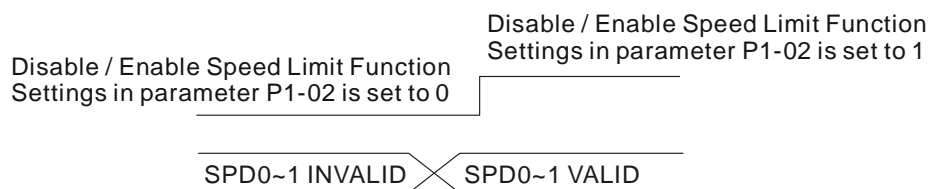
6.6.1 Speed Limit

The max. servo motor speed can be limited by using parameter P1-55 no matter in position, speed or torque control mode.

The command source of speed limit command is the same as speed command. It can be the external analog voltage but also can be internal parameters (P1-09 to P1-11). For more information of speed command source, please refer to chapter 6.3.1.

The speed limit only can be used in torque mode (T mode) to limit the servo motor speed. When the torque command is the external analog voltage, there should be surplus DI signal that can be treated as SPD0~1 and be used to select speed limit command (internal parameter). If there is not enough DI signal, the external voltage input can be used as speed limit command. When the Disable / Enable Speed Limit Function Settings in parameter P1-02 is set to 1, the speed limit function is activated.

The timing chart of speed limit is shown as the figure below:



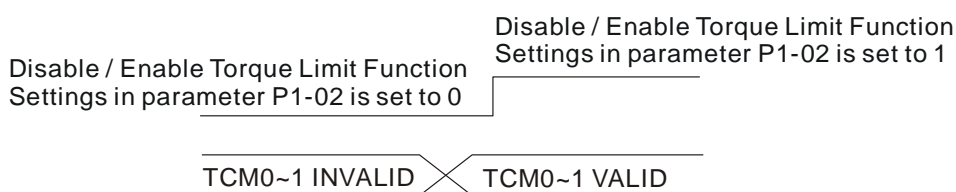
Command Source Selection of Speed Limit

6.6.2 Torque Limit

The command source of torque limit command is the same as torque command. It can be the external analog voltage but also can be internal parameters (P1-12 to P1-14). For more information of torque command source, please refer to chapter 6.4.1.

The torque limit only can be used in position mode (PT and PR mode) and speed mode (S mode) to limit the output torque of servo motor. When the position command is the external pulse and speed command is the external analog voltage, there should be surplus DI signal that can be treated as TCM0~1 used to select torque limit command (internal parameter). If there is not enough DI signal, the external voltage input can be used as torque limit command. When the Disable / Enable Torque Limit Function Settings in parameter P1-02 is set to 1, the torque limit function is activated.

The timing chart of torque limit is shown as the figure below:



Command Source Selection of Torque Limit

6.6.3 Analog Monitor

Users can use analog monitor to observe the required analog voltage signals. ASDA-A2 series servo drives provide two analog channels, they are PIN No. 15 and 16 of CN1 connector. The parameters relative to analog monitor are shown below.

Relevant parameters:

P0 - 03	MON	Analog Monitor Output	Address: 0006H, 0007H
----------------	------------	------------------------------	------------------------------

Default: 01

Related Section:

Applicable Control Mode: ALL

Section 4.3.5

Unit: N/A

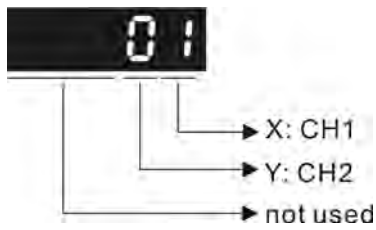
Range: 00 ~ 77

Data Size: 16-bit

Display Format: Hexadecimal

Settings:

This parameter determines the functions of the analog monitor outputs.



XY: (X: CH1; Y: CH2)

- 0: Motor speed (+/-8V / maximum motor speed)
- 1: Motor torque (+/-8V / maximum torque)
- 2: Pulse command frequency (+8Volts / 4.5Mpps)
- 3: Speed command (+/-8Volts / maximum speed command)
- 4: Torque command (+/-8Volts / maximum torque command)
- 5: V_BUS voltage (+/-8Volts / 450V)
- 6: Reserved
- 7: Reserved

Please note: For the setting of analog output voltage proportion, refer to the P1-04 and P1-05.

Example:

P0-03 = 01(CH1 is speed analog output)

Motor speed = (Max. motor speed × V1/8) × P1-04/100, when the output voltage value of CH1 is V1.

P1 - 03	AOUT	Pulse Output Polarity Setting	Address: 0106H, 0107H
----------------	-------------	--------------------------------------	------------------------------

Default: 0

Related Section:

Applicable Control Mode: ALL

Section 3.3.3

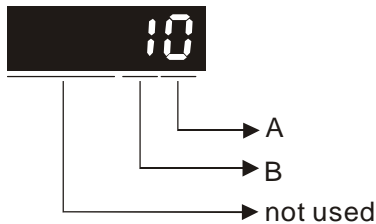
Unit: N/A

Range: 0 ~ 13

Data Size: 16-bit

Display Format: Hexadecimal

Settings:



This parameter is used to determine the polarity of analog monitor outputs and position pulse outputs. The analog monitor outputs can be configured with different polarity individually, but the position pulse outputs have to be each with the same polarity.

A: Analog monitor outputs polarity

0: MON1(+), MON2(+)

1: MON1(+), MON2(-)

2: MON1(-), MON2(+)

3: MON1(-), MON2(-)

B: Position pulse outputs polarity

0: Forward output

1: Reverse output

P1 - 04	MON1	Analog Monitor Output Proportion 1 (CH1)	Address: 0108H, 0109H
----------------	-------------	---	------------------------------

Default: 100

Related Section:

Applicable Control Mode: ALL

Section 6.4.4

Unit: % (full scale)

Range: 0 ~ 100

Data Size: 16-bit

Display Format: Decimal

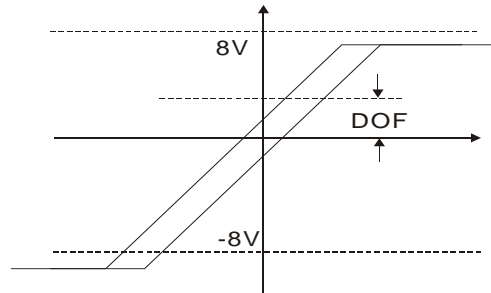
P1 - 05	MON2	Analog Monitor Output Proportion 2 (CH2)	Address: 010AH, 010BH
Default: 100		Related Section:	
Applicable Control Mode: ALL		Section 6.4.4	
Unit: % (full scale)			
Range: 0 ~ 100			
Data Size: 16-bit			
Display Format: Decimal			

P4 - 20	DOF1	Analog Monitor Output Drift Adjustment (CH1)	Address: 0428H, 0429H
Default: Factory setting		Related Section:	
Applicable Control Mode: ALL		Section 6.4.4	
Unit: mV			
Range: -800 ~ 800			
Data Size: 16-bit			
Display Format: Decimal			
Settings:			
Please note that when P2-08 is set to 10, the users cannot reset this parameter.			

P4 - 21	DOF2	Analog Monitor Output Drift Adjustment (CH2)	Address: 042AH, 042BH
Default: Factory setting		Related Section:	
Applicable Control Mode: ALL		Section 6.4.4	
Unit: mV			
Range: -800 ~ 800			
Data Size: 16-bit			
Display Format: Decimal			
Settings:			
Please note that when P2-08 is set to 10, the users cannot reset this parameter.			

For example, when the users want to observe the analog voltage signal of channel 1, if the monitor output setting range is 8V per 325Kpps, then it is needed to change the setting value of parameter P1-04 (Analog Monitor Output Proportion 1) to 50 (=325Kpps/Max. input frequency). Other related parameters setting include parameter P0-03 (A=3) and P1-03 (A=0~3, output polarity setting). In general, when output voltage value of Ch1 is V1, the pulse command frequency is equal to (Max. input frequency × V1/8) × P1-04/100.

Because there is an offset value of analog monitor output voltage, the zero voltage level of analog monitor output does not match to the zero point of setting value. We recommend the users can use Analog Monitor Output Drift Adjustment, DOF1 (parameter P4-20) and DOF2 (parameter P4-21) to improve this condition. The maximum output voltage range of analog monitor output is $\pm 8V$. If the output voltage exceed its limit, it is still limited within the range of $\pm 8V$. The resolution provided by ASDA-A2 series servo drives is 10bit, approximated to 13mv/LSB.



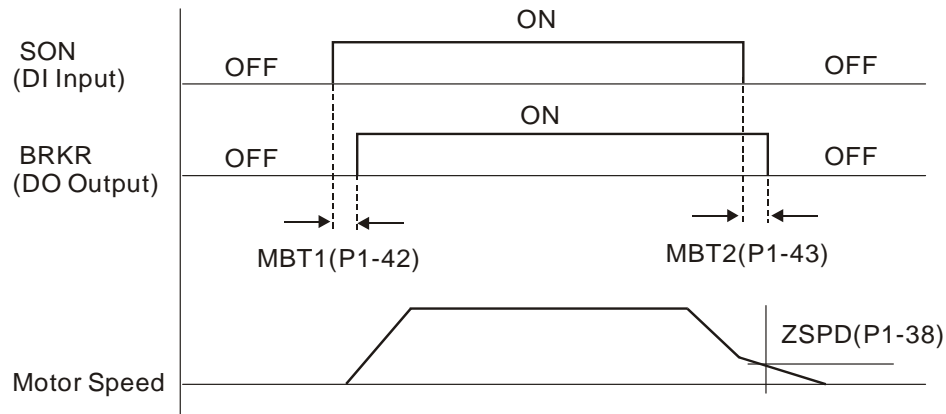
6.6.4 Electromagnetic Brake

When the servo drive is operating, if the digital output BRKR is set to Off, it indicates the electromagnetic brake is disabled and motor is stop running and locked. If the digital output BRKR is set to ON, it indicates electromagnetic brake is enabled and motor can run freely.

There are two parameters that affect the electromagnetic brake. One is parameter P1-42 (MBT1) and the other is parameter P1-43 (MBT2). The users can use these two parameters to set the On and Off delay time of electromagnetic brake. The electromagnetic brake is usually used in perpendicular axis (Z-axis) direction to reduce the large energy generated from servo motor. Using electromagnetic brake can avoid the load may slip since there is no motor holding torque when power is off. Without using electromagnetic brake may reduce the life of servo motor. To avoid malfunction, the electromagnetic brake should be activated after servo system is off (Servo Off).

If the users desire to control electromagnetic brake via external controller, not by the servo drive, the users must execute the function of electromagnetic brake during the period of time when servo motor is braking. The braking strength of motor and electromagnetic brake must be in the same direction when servo motor is braking. Then, the servo drive will operate normally. However, the servo drive may generate larger current during acceleration or at constant speed and it may the cause of overload (servo fault).

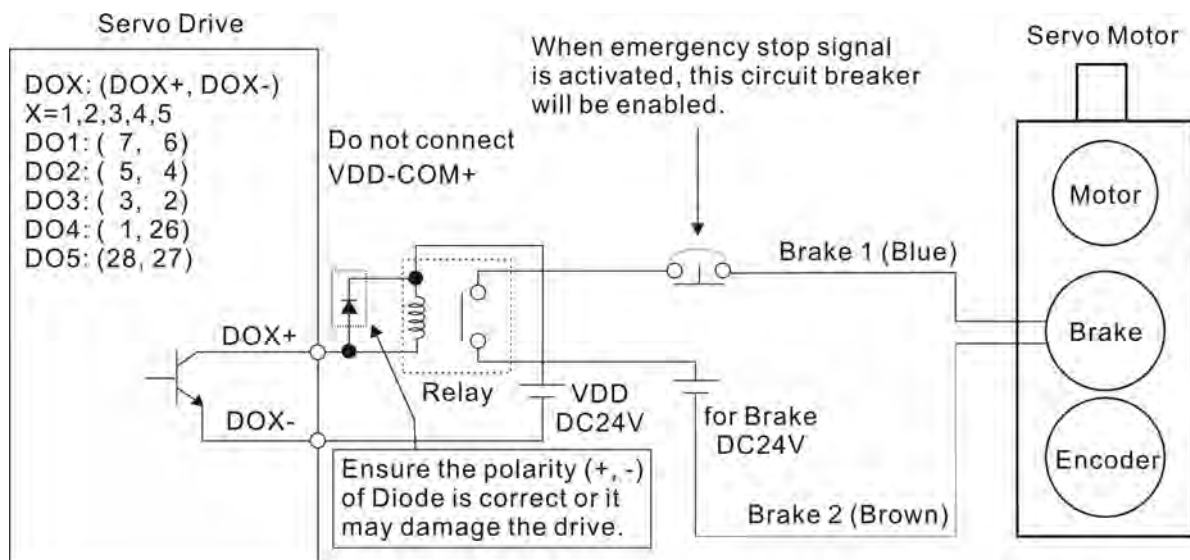
Timing chart for using servo motor with electromagnetic brake:



BRKR output timing explanation:

1. When Servo Off (when DI SON is not activated), the BRKR output goes Off (electromagnetic brake is locked) after the delay time set by P1-43 is reached and the motor speed is still higher than the setting value of P1-38.
2. When Servo Off (when DI SON is not activated), the BRKR output goes Off (electromagnetic brake is locked) if the delay time set by P1-43 is not reached and the motor speed is still lower than the setting value of P1-38.

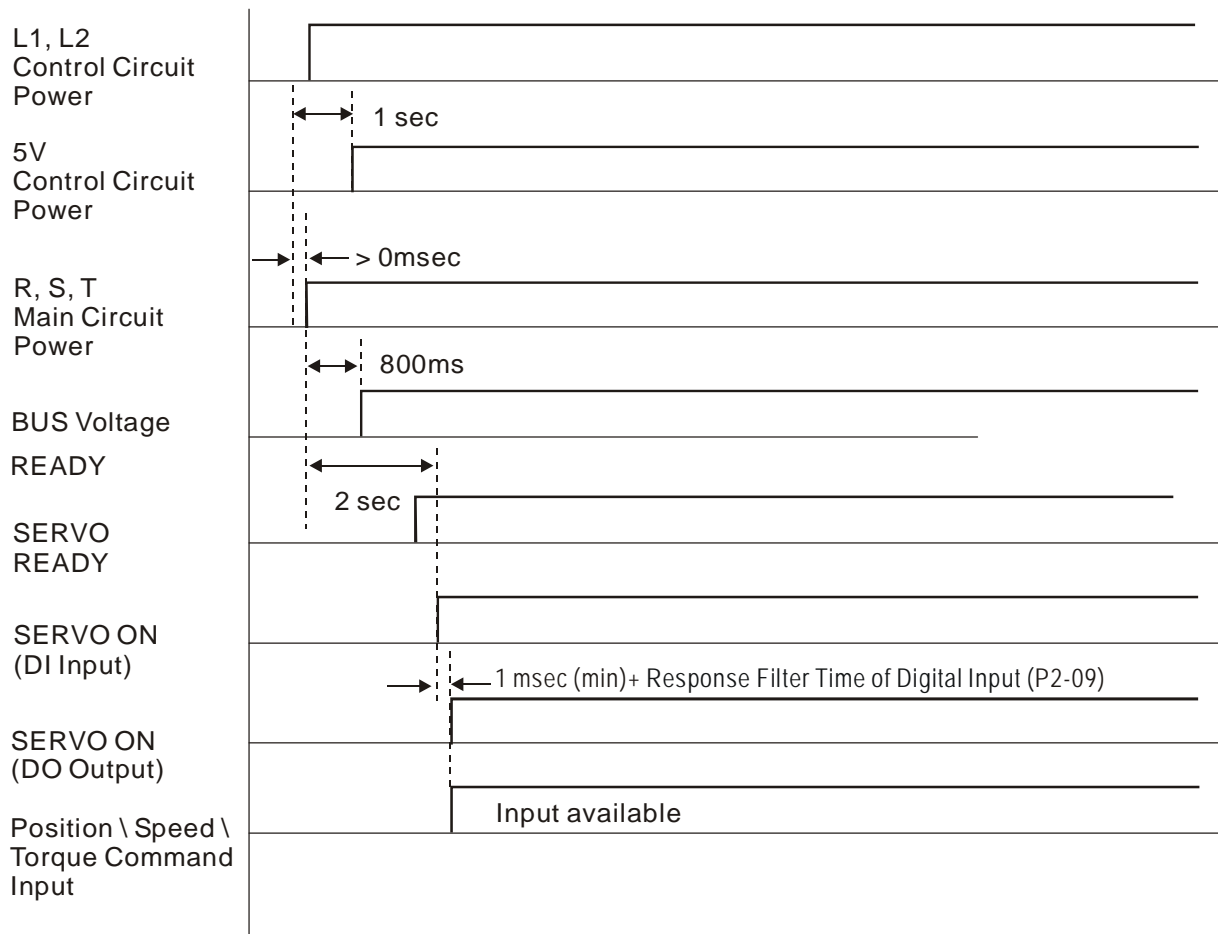
Electromagnetic Brake Wiring Diagram



NOTE

- 1) Please refer to Chapter 3 Connections and Wiring for more wiring information.
- 2) The BRKR signal is used to control the brake operation. The VDD DC24V power supply of the servo drive can be used to power the relay coil (Relay). When BRKR signal is ON, the motor brake will be activated.
- 3) Please note that the coil of brake has no polarity.
- 4) The power supply for brake is DC24V. Never use it for VDD, the +24V source voltage.

The timing charts of control circuit power and main circuit power:



This page intentionally left blank.

Chapter 7 Motion Control Functions

7.1 Motion Control Functions

ASDA-A2 series provides the following motion control functions:

- 1) Innovative PR mode
- 2) Capture (Position Latch) / Compare (Position Detection) functions
- 3) Electronic Cam (E-Cam) function (ASDA-A2 series L type models does not provide this function.)

7.2 System Information

The system information of the servo drive includes:

1. System Parameters; 2. Monitor Parameters; 3. Data Array

Please refer to the following table below.

	System Parameters	Monitor Parameters
Usage	Applied to function settings or commands, for example, position/speed/torque control modes, position/speed loop gain and other settings.	For monitoring status of servo operating, for example, speed, position, torque and other settings.
Display Method	LED Display: display PX-XX on the display for example P1-01. Press the SET key to display the setting value of parameters. For the operation of the digital keypad, please refer to Chapter 4.	Set P0-02 directly to enter into monitor mode and specify the monitor status. The monitor status depends on the setting value of P0-02. Press MODE key on the keypad is to enter into monitor mode directly. For the operation of the digital keypad, please refer to Chapter 4.
Access Method	There are 16-bit and 32-bit parameters which can be read/written via several ways.	Read only
Data Length	16-bit or 32-bit (depends on the settings of parameters)	32-bit integer
Communication	Support MODBUS/CANopen/USB Read & Write, each parameter occupies two MODBUS addresses.	<ul style="list-style-type: none"> ● Monitoring is accomplished through USB (upon PC software) ● Do not support MODBUS/CANopen Read & Write directly unless users use mapping function to monitor the specified monitor parameters via the corresponding system parameters.
Mapping Parameters	P0-25 ~ P0-32, total 8 parameters (Determined by P0-35 ~ P0-42)	P0-09 ~ P0-13, total 5 parameters (Determined by P0-17 ~ P0-21)

	System Parameters	Monitor Parameters
Remark	-	In monitor mode, users can press UP or DOWN arrow key to change the monitoring variables (monitor item settings) in common use (code 0 ~ 26). Please note that not all monitoring variables can be displayed (total 150 kinds of monitor parameters).

7.2.1 Monitoring Variables

Please refer to the following table for the explanation of monitoring variables:

Item	Explanation
Code	Each monitoring variable has one corresponding code. Using the parameter P0-02 is able to set this code and perform status monitoring.
Format	Each monitoring variable is saved in 32-bit (long integer) in the servo drive.
Type	There are two types of monitoring variables, basic monitoring variables and extension monitoring variables: <ol style="list-style-type: none"> 1. Basic monitoring variables: Enter into the monitor mode by pressing MODE key on the digital keypad. In monitor mode, press UP/DOWN arrow keys to find the available basic monitoring variables (P0-02=0~26). 2. Extension monitoring variables: Other monitoring variables are called extension monitoring variables except basic monitoring variables (P0-02=27~127).
Monitor Method	There are two methods for status monitoring. One is through LED display of the digital keypad and the other is via the mapping parameters: <ol style="list-style-type: none"> 1. LED display of digital keypad: Status monitoring through the LED display of the digital keypad directly. 2. Mapping parameters: The settings of the monitoring variables will be reflected on the setting value of the mapping parameters. Users can know the settings of the monitoring variables through the corresponding parameters.
Display	<ol style="list-style-type: none"> 1. Press MODE key to switch the monitor mode and then press UP/DOWN arrow keys to select the desired monitoring variables. 2. Set P0-02 directly and then display the settings of the desired monitoring variables. Press SHIFT key to switch high/low byte display; Press SET key to switch decimal/hexadecimal display.
Mapping Function	<ol style="list-style-type: none"> 1. The parameters which support mapping function includes: P0-09 ~ P0-13. (Please refer to section 8.3 "Detailed Parameter Listings" of Chapter 8. 2. Using mapping parameters and read & write monitor parameters through communication. 3. The setting values of P0-09 ~ P0-13 (Status Monitor 1 ~ 5) are the content of basic monitoring variables (17h, 18h, 19h, 1Ah). When users want to monitor P0-09, set P0-17 first to read the status value (see P0-02). When reading the drive status through Modbus communication, the system will read the monitor status which specified by P0-17. When reading the drive status through the keypad, if P0-02 is set to 23, VAR-1 will quickly show for about two seconds and then the value of P0-09 will display on the display.

Attribute of monitoring variables:

Attribute	Explanation
B	Basic monitoring variable. Pressing UP / DOWN keys can change the status shown on LED display.
Dn	Decimal place display. D1 indicates one decimal place, D2 indicates two decimal places.
Dec	Decimal display only. When pressing SET key on the keypad, the system can not switch to hexadecimal display.
Hex	Hexadecimal display only. When pressing SET key on the keypad, the system can not switch to decimal display.

Explanation of monitoring variables:

Code	Monitoring Variables / Attribute	Explanation
000 (00h)	Feedback position (PUU) B	Motor feedback – current position. Unit is user unit, PUU.
001 (01h)	Position command (PUU) B	Position command – current position. Unit is user unit, PUU. PT mode: it indicates the pulse command received by the servo drive. PR mode: it indicates the absolute position command. It is equal to the pulse number sent by the host (external) controller.
002 (02h)	Position error (PUU) B	Position error counts between position command pulse and feedback pulse. Unit is user unit, PUU.
003 (03h)	Feedback position (pulse) B	Motor feedback – current position. Unit is encoder unit, pulse.
004 (04h)	Position command (pulse) B	Position command – current position. Unit is encoder unit, pulse. It is also the position command after electronic gear ratio is set.
005 (05h)	Position error (pulse) B	Position error counts between position command pulse and feedback pulse. Unit is encoder unit, pulse.
006 (06h)	Input frequency of pulse command B	Input frequency of pulse command received by the servo drive. Unit is Kpps. Applicable for PT and PR mode.
007 (07h)	Feedback speed B D1 Dec	Actual motor speed. Unit is 0.1r/min. The low-pass filter function is used so the value is more stable.
008 (08h)	Speed input command (Analog) B D2 Dec	Analog speed input command. Unit is 0.01Volt.
009 (09h)	Speed command (Integrated) B	Integrated speed input command. Unit is 1r/min. The command source may be from analog command / internal parameter / position loop.

Code	Monitoring Variables / Attribute	Explanation
010 (0Ah)	Torque command (Analog) B D2 Dec	Analog torque input command. Unit is 0.01 Volt.
011 (0Bh)	Torque command (Integrated) B	Integrated torque input command. Unit is Percent (%). The command source may be from analog command / internal parameter / position loop.
012 (0Ch)	Average load B	Average load output by the servo drive. Unit is Percent (%).
013 (0Dh)	Peak load B	Peak load output by the servo drive. Unit is Percent (%) .
014 (0Eh)	DC Bus voltage B	Main circuit voltage after rectification. Unit is Volt.
015 (0Fh)	Ratio of load inertia to motor inertia B D1 Dec	Ratio of load inertia to motor inertia. Unit is 0.1times.
016 (10h)	IGBT temperature B	IGBT temperature. Unit is °C.
017 (11h)	Resonance frequency B Dec	Resonance frequency of the mechanical system. There are two groups of resonance frequency: F1 and F2 When reading the drive status through the keypad, pressing SHIFT key can switch the display of F1 and F2. F2: no decimal point; F1: display one decimal point When reading the drive status through the communication, Low 16-bit (Low Byte) will display frequency F2 High 16-bit (High Byte) will display frequency F1
018 (12h)	Absolute pulse number relative to encoder (use Z phase as home) B Dec	Absolute pulse number relative to encoder (use Z phase as home). The value of Z phase home point is 0, and it can be the value from -5000 to +5000 pulses. When the value is higher, the deviation pulse number is higher too.
019 (13h)	Mapping parameter #1 B	Display the content of parameter P0-25 (mapping target is specified by parameter P0-35).
020 (14h)	Mapping parameter #2 B	Display the content of parameter P0-26 (mapping target is specified by parameter P0-36).
021 (15h)	Mapping parameter #3 B	Display the content of parameter P0-27 (mapping target is specified by parameter P0-37).
022 (16h)	Mapping parameter #4 B	Display the content of parameter P0-28 (mapping target is specified by parameter P0-38).
023 (17h)	Status monitor #1 B	Display the content of parameter P0-09 (the monitor status is specified by parameter P0-17).
024 (18h)	Status monitor #2 B	Display the content of parameter P0-10 (the monitor status is specified by parameter P0-18).
025 (19h)	Status monitor #3 B	Display the content of parameter P0-11 (the monitor status is specified by parameter P0-19).

Code	Monitoring Variables / Attribute	Explanation
026 (1Ah)	Status monitor #4 B	Display the content of parameter P0-12 (the monitor status is specified by parameter P0-20).
039 (27h)	DI status (Integrated) Hex	Integrated DI status. Each bit corresponds to one channel of digital input. The command source may be from DI signal or communication control (upon software). P3-06 can determine how digital inputs accept commands.
040 (28h)	DO status (Hardware) Hex	Actual DO output status. Each bit corresponds to one channel of digital output.
041 (29h)	Drive Status	The drive status will display via P0-46. Please refer to P0-46 for explanation.
043 (2Bh)	Capture data	The latest captured data by using Capture function. Note: Using Capture function is able to capture many positions.
048 (30h)	Auxiliary encoder CNT	Pulse counts input by auxiliary encoder (CN5).
049 (31h)	Pulse command CNT	Pulse counts input by pulse command (CN1).
050 (32h)	Speed command (Integrated) D1 Dec	Integrated speed input command. Unit is 0.1r/min. The command source may be from analog command / internal parameter / position loop.
051 (33h)	Feedback speed (Instant) D1 Dec	Actual motor speed. Unit is 0.1r/min.
052 (34h)	Feedback speed (Filter) D1 Dec	Actual motor speed. Unit is 0.1r/min. (The low-pass filter function is used.)
053 (35h)	Torque command (Integrated) D1 Dec	Integrated torque command. Unit is 0.1Percent (%). The command source may be from analog command / internal parameter / speed loop.
054 (36h)	Feedback Torque D1 Dec	Actual motor torque. Unit is 0.1Percent (%).
055 (37h)	Feedback current D2 Dec	Actual motor current. Unit is 0.01ampere (Amp).
056 (38h)	DC Bus voltage D1 Dec	Main circuit voltage after rectification. Unit is 0.1Volt.
059 (3Bh)	Pulse number of E-Cam master axis (Accumulated)	The accumulated pulse numbers of master axis of electronic cam. Please refer to P5-86. (ASDA-A2 series L type models does not provide this function.)
060 (3Ch)	Pulse number of E-Cam master axis (Incremental)	The incremental pulse numbers of master axis of electronic cam every 1msec. (ASDA-A2 series L type models does not provide this function.)

Code	Monitoring Variables / Attribute	Explanation
061 (3Dh)	Pulse number of E-Cam master axis (Lead Pulse Number)	Lead pulse number of E-Cam master axis which is used to decide the engage condition. 1. Before the electronic gear engaged: Lead pulse number is determined by P5-87 or P5-92. The electronic cam engaged when the setting value is 0. 2. After the electronic gear engaged: Lead pulse number is determined by P5-89. The electronic cam disengaged when the setting value is 0. (ASDA-A2 series L type models does not provide this function.)
062 (3Eh)	Position of E-Cam axis	The position of E-Cam axis. The input of E-Cam curve. Unit: It is the same as the pulse number of master axis. After receiving the pulse number P of master axis, E-Cam axis will operate M cycles. It indicates that there are M cycles of the E-Cam curve (P5-83=M, P5-84=P). (ASDA-A2 series L type models does not provide this function.)
063 (3Fh)	Position of E-Cam slave axis	The position of slave axis of E-Cam. The output of E-Cam curve. Unit: It is the data unit of E-Cam curve. (ASDA-A2 series L type models does not provide this function.)
064 (40h)	End register of PR command.	In PR mode, it is the end of the position command (Cmd_E).
065 (41h)	Output register of PR command.	In PR mode, it is the accumulated outputs of position command.
067 (43h)	Target speed of PR command.	It is target speed of PR path command. Unit is PPS (Pulse Per Second).
068 (44h)	S-curve filter (Input)	Input data of S-curve filter which is used to create the effect of S-curve filter. In PR mode, it is valid for both E-Cam and internal speed command. (ASDA-A2 series L type models does not provide this function.)
069 (45h)	S-curve filter (Output)	Output data of S-curve filter which is used to create the effect of S-curve filter. In PR mode, it is valid for both E-Cam and internal speed command. (ASDA-A2 series L type models does not provide this function.)
076 (4Ch)	Speed command of PR mode	In PR mode, it is the terraced speed curve drawn up according to target speed / accel & decel time / position move (before using S-curve filter). Unit is PPS (Pulse Per Second).
081 (51h)	Synchronous Capture Axis - Pulse input increment	When Synchronous Capture Axis is enabled, it is the received pulses between two capture operation and it can be used to measure the actual mark distance.

Code	Monitoring Variables / Attribute	Explanation
084 (54h)	Synchronous Capture Axis - Synchronous error pulse number	When Synchronous Capture Axis is enabled, it is the accumulated errors between actual output pulse and target pulse. After the synchronization operation is completed, this value will be near to zero (0).
096 (60h)	Firmware version of servo drive Dec	Includes 2 versions: DSP and CPLD When reading the firmware version through the keypad, pressing SHIFT key can switch the version display of DSP and CPLD. DSP: no decimal place; CPLD: it will display one decimal place. When reading the firmware version through the communication (using mapping parameters): Low 16-bit (Low Word) will display DSP firmware version. High 16-bit (High Word) will display CPLD firmware version.
098 (62h)	PLC scan time	It is regarded as the refresh time of digital inputs and outputs. Unit is 0.5msec.
109 (6Dh)	Data array capacity	Display the capacity of data array. Unit is DWORD (32-bit).
111 (6Fh)	Servo fault code	Display servo fault code. But it only displays the servo drive fault code. The fault code for motion control will not be displayed.
112 (70h)	CANopen synchronous time (Low-pass filter is not used)	Display the time when the servo drive receives synchronous signal (TimeStamp). Unit is usec.
113 (71h)	CANopen synchronous time (Low-pass filter is used)	Display the time when the servo drive receives synchronous signal and low-pass filter is used. Unit is usec.
114 (72h)	CANopen synchronous timing correction	When CANopen communication is enabled, display the timing correction value which is synchronized with the host (external) controller. Unit is usec.
123 (7Bh)	Keypad monitor value	When reading the monitor value through the keypad, it is used to read the monitor value displayed on the keypad.

7.2.2 Data Array

ASDA-A2 series provides many motion control functions, such as E-Cam (ASDA-A2 series L type models does not provide this function.), Capture function, and Compare function. The data array can keep data for E-Cam, Capture function, and Compare function with maximum to 800 records (all together to max. 800 records). Please refer to the following table for the introduction of data array.

Data Array	
Usage	<ul style="list-style-type: none"> ● Save Capture data. ● Save Compare data. ● Save E-Cam curve. <p>Note:</p> <ol style="list-style-type: none"> 1. The data array is user-defined and the system will not partition off the data array for Capture, Compare and E-Cam function respectively. Therefore, the memory blocks of the data array may be overlapped. Please pay close attention when defining the data array. 2. ASDA-A2 series L type models does not provide this function.
Array Size	<ul style="list-style-type: none"> ● 32-bit integer x 800 records (the data address when reading and writing data array is determined by P5-10). ● Each data should have a corresponding address. This address should be specified when reading and writing data array. ● The address is within the range of 0 ~ 799.
Backup Data Into EEPROM	<ul style="list-style-type: none"> ● Set P2-08 to 30 first and set to 35 next. Then, the content of the data array will be saved in EEPROM when power is off. ● Please save data when Servo Off. ● After re-power the servo drive, the content of the data array will be written automatically.
Read/Write Window	<ul style="list-style-type: none"> ● Perform read and write operation through P5-10 ~ P5-13.

The content of the data array can not be read and written via external commands. It only can be read and written through the settings of P5-10 ~ P5-13. Please refer to the following table for explanation:

Relevant Parameters for Data Array		
Parameter	Name	Explanation
P5-10	Data Amount (N x 32 bits)	This parameter is used to set the data amount of data array (N x 32 bits). N is the capacity of the data array (Read only).
P5-11	Read / Write Address	This parameter is used to set the data address when reading and writing data array.

Relevant Parameters for Data Array		
Parameter	Name	Explanation
P5-12	Read / Write Window #1	Panel Read: P5-11 unchanged Panel Write: P5-11=P5-11+1 When reading data through the panel (keypad): Read the content specified by P5-11. After read operation is completed, the address of P5-11 will not change. When writing data through the panel (keypad): Write the content specified by P5-11. After write operation is completed, the address of P5-11 will increase 1 automatically.
		Communication Read: P5-11=P5-11+1 Communication Write: P5-11=P5-11+1 When reading data through the communication: Read the content specified by P5-11. After read operation is completed, the address of P5-11 will increase 1 automatically. When writing data through the communication: Write the content specified by P5-11. After write operation is completed, the address of P5-11 will increase 1 automatically.
P5-13	Read / Write Window #2	Panel Read: P5-11=P5-11+1 Panel Write: Inhibition When reading data through the panel (keypad): Read the content specified by P5-11. After read operation is completed, the address of P5-11 will increase 1 automatically. When writing data through the panel (keypad): This parameter can not be written through the keypad.
		Communication Read: P5-11=P5-11+1 Communication Write: P5-11=P5-11+1 When reading data through the communication: Read the content specified by P5-11. After read operation is completed, the address of P5-11 will increase 1 automatically. When writing data through the communication: Write the content specified by P5-11. After write operation is completed, the address of P5-11 will increase 1 automatically.

Access to Data Array

There is one index working along with two read/write windows for accessing data array.

For some hosts resending data several times while communication, it had better to put the index P5-11 every time before read/write.

In brief, users need to set the desired read & write address by using P5-11 and then read and write the data through P5-12 or P5-13.

For example, suppose that users want to write three consecutive numbers of data (100th, 200th, 300th), and save them into the address 11, 12, 13 of data array, the operation steps are described as follows:

1. When writing data through the keypad:

Use P5-12 because P5-13 does not provide this function.

1) Set first address:

Set P5-11=11 (the first address)

2) Write data:

Set P5-12=100. (This is the first written data, 100th data and it will be saved in address 11, i.e. P5-11. After write operation is completed, the address of P5-11 will increase 1 automatically, i.e. address 12.)

Set P5-12=200 (This is the secondary written data, 200th data and it will be saved in address 12, i.e. P5-11. After write operation is completed, the address of P5-11 will increase 1 automatically, i.e. address 13.)

Set P5-12=300 (This is the third written data, 300th data and it will be saved in address 13, i.e. P5-11. After write operation is completed, the address of P5-11 will increase 1 automatically, i.e. address 14.)

Then, users can read the address 11, 12, and 13 and check the written values.

2. When reading data through the keypad:

Use P5-13 to read consecutive data.

1) Set first address:

Set P5-11=11 (the first address)

2) Read data:

When display shows P5-13:

Press SET key at the first time, the display will show the 100th data saved in address 11. Pressing MODE key can exit P5-13.

Press SET key at the second time, the display will show the 200th data saved in address 12. Pressing MODE key can exit P5-13.

Press SET key at the first time, the display will show the 300th data saved in address 13. Pressing MODE key can exit P5-13.

Please note that when use P5-13 to read data every time, the address of P5-11 will increase 1 automatically so using P5-13 can read the consecutive data. However, if users use P5-12 to read the data, the address of P5-11 will remain the same, so using P5-12 can not read the consecutive data.

The operation steps for reading or writing data through the communication are similar to the steps when using keypad. The functions of P5-12 and P5-13 are also the same. For example, suppose that users want to write 6 consecutive data (100th, 200th, 300th, 400th, 500th, 600th data) through Modbus communication continuously, set the communication command by referring to the table below.

Communication command: write data into data array									
No.	Command	Starting Data Address	Data Amount	P5-11		P5-12		P5-13	
				Low Word	High Word	Low Word	High Word	Low Word	High Word
1	0x10	P5-11	6 (Word)	11	0	100	0	200	0
				First Address		First Data		Second Data	
2	0x10	P5-11	6 (Word)	13	0	300	0	400	0
				Third Address		Third Data		Fourth Data	
3	0x10	P5-11	6 (Word)	15	0	500	0	600	0
				Fifth Address		Fifth Data		Sixth Data	

Please check if the above written data is correct when reading the data of data array.

Users can use Modbus communication command 0x06(write one data) to set P5-11 and write the desired read data. For the settings of the communication command, please refer to the table below.

Communication command: read data from data array			
No.	Command	Starting Data Address	Written Data
4	0x06	P5-11	11

Then, read the data of the specified address by using communication command 0x03.

Please refer to the table below to set communication command.

Communication command: Read data array				Response Data					
No.	Command	Starting Data Address	Data Amount	P5-11		P5-12		P5-13	
				Low Word	High Word	Low Word	High Word	Low Word	High Word
5	0x03	P5-11	6 (Word)	11	0	100	0	200	0
				Read Address		Data of address 11		Data of address 12	
6	0x03	P5-11	6 (Word)	13	0	300	0	400	0
				Read Address		Data of address 13		Data of address 14	
7	0x03	P5-11	6 (Word)	15	0	500	0	600	0
				Read Address		Data of address 15		Data of address 16	

7.3 Motion Axes

Motion axis is a counter within the servo drive which is used to count the data of absolute position (32-bit integer). The available motion axes are introduced in the following table.

Axis Name	Description	Read (R) / Write (W)	Attribute
1. Motor Encoder Axis (P5-16)	It indicates the motor absolute feedback position and the user unit is PUU.	R	Physical Axis
2. Auxiliary Encoder Axis (P5-17)	It is the pulse counts of the auxiliary encoder (linear scale) input by CN5. The pulse type is AB phase pulse only.	R/W	Physical Axis
3. Pulse Command Axis (P5-18)	It is the pulse counts of the host (external) controller input from CN1. The pulse type can be defined by P1-00.	R/W	Physical Axis
4. Capture Axis (P5-37)	It is the motion axis which is used to enable Capture function. The command source could be from motor encoder axis, auxiliary encoder axis and pulse command axis. Position offset exists between output axis and physical axis. After the first point is captured, the axis position can be defined again.	R/W	Output Axis
5. Compare Axis (P5-57)	It is the motion axis which is used to enable Compare function. The command source could be from motor encoder axis, auxiliary encoder axis, pulse command axis and Capture axis. Position offset exists between output axis and physical axis.	R/W	Output Axis
6. E-Cam Master Axis (P5-86)	It is the master axis of electronic cam. The command source could be from auxiliary encoder axis, pulse command axis, Capture axis and PR command axis. Position offset exists between output axis and physical axis. (ASDA-A2 series L type models does not provide this function.)	R/W	Output Axis
7. PR Command Axis	Command position defined by PR.	R	Virtual Axis
8. Internal Time Axis	Internal timer. The value will increase 1 every 1msec.	R	Virtual Axis
9. Synchronous Capture Axis (P5-77)	The function is similar to Capture axis (P5-37). But, it will correct the offset value of this synchronous axis (P5-78) when capture operation is activated every two times. (This function is available only in firmware version V1.009 and later models).	R/W	Virtual Axis

Please note:

1. Physical axis: Position value is obtained from the actual terminal signal counts.
2. Output axis: It is the axis output by the physical axis. The value will not be the same as the source of physical axis, but the increasing value will be the same as the increasing value of physical axis.

3. Virtual axis: It is the axis generated by the servo firmware, e.g. PR command axis. It is unable to command in real time so it could not be regarded as the command axis for Capture and Compare function. But it could be regarded as the command source of the master axis of electronic cam.

7.4 PR Mode

PR mode could be composed of one position command or multiple position commands, and triggered by DI signal, CTRG. DI signals, POS0 ~ POS5 are used to specify the desired trigger position.

In PR mode, electronic cam (E-Cam) is provided. Users can enable electronic cam function by PRs (Position Registers). After the electronic cam is disengaged, the system can command the motor to return to the specified position as well. The PR cannot be interpreted as “Point to Point” control. It does beyond that. The servo is capable to change its working profile under PR mode instantaneously. There are 64 PRs available.

7.5 Comparison

	Old PR mode	PR Mode of ASDA-A2
Position settings	8 position settings	64 position registers (64PRs)
Command Type	Position command	Homing mode, constant speed mode, position control mode, jump mode, write parameter mode are available.
Parameters for Position Commands	<ul style="list-style-type: none"> ● Either Absolute command or Incremental command ● Accel / Decel time x 1 ● Motion speed x 8 ● Delay time x 8 	<ul style="list-style-type: none"> ● Absolute command / Incremental command can be set individually. ● Accel / Decel time x 16 ● Motion speed x 16 ● Delay time x 16
Command Trigger Timing	It is enabled when DO signal, ZSPD is On.	It can be enabled at any time. Users can specify the command connection method (sequential command / insertion command / overlap command).
Trigger Method	<ul style="list-style-type: none"> ● DI signals: CTRG + POSn (n: number) 	<ul style="list-style-type: none"> ● DI signals: CTRG + POSn (n: number) ● Event trigger function: DI signals EV1 ~ 4 + CAP_OK ● P5-07 (Trigger Position Command)
Position Command Profile	<ul style="list-style-type: none"> ● Accel / Decel S-curve (When S-curve function (P1-36) is disabled, the acceleration and deceleration function are also disable.) 	<ul style="list-style-type: none"> ● Accel / Decel S-curve (When S-curve function (P1-36) is disabled, the acceleration and deceleration function can be enabled still.)
Format	<ul style="list-style-type: none"> ● Rotation or Pulse 	<ul style="list-style-type: none"> ● 32-bit data (user unit)

	Old PR mode	PR Mode of ASDA-A2
Homing Function	<ul style="list-style-type: none"> ● Execute homing function automatically when power is applied to the servo drive (Servo On at the first time) ● DI signal, SHOM 	<ul style="list-style-type: none"> ● Execute homing function automatically when power is applied to the servo drive (Servo On at the first time) ● DI signal, SHOM ● When PR path is set to 0, it is homing mode. Users also can use DI signal, CTRG to trigger PR path 0. ● After homing operation is completed, it can execute the specified PR path.
Software Limit Function	This function is not provided.	This function is provided.

7.6 Pulse of User Unit

The position command unit of PR mode is presented by PUU (Pulse of User Unit). It also indicates the ratio of position command unit of host (external) controller to internal position command unit of servo drive, i.e. electronic gear ratio of servo drive.

The PUU is a unit which is scaled by the electronic gear. This will bring out an advantage, and that is "YOU SEE WHAT YOU COMMAND". For example, if you send 10000 PUU for command and you can read from the feedback 10000 PUU and ignore the electronic gear ratio.

- 1) Position command unit of servo drive (pulse): encoder unit, 1280000pulses per revolution (pulse/rev).
- 2) User unit (PUU): unit of host (external) controller. If the pulse number per revolution is P pulses (PUU/rev), then the electronic gear ratio should be set to:

$$\text{GEAR_NUM}(P1-44) / \text{GEAR_DEN}(P1-45) = 1280000 / P$$

7.7 Position Registers

- 1) The unit of position register of PR mode: They are indicates as user unit, PUU.
- 2) Cmd_E (Monitoring Variable 064): The target position of command.
- 3) Cmd_O (Monitoring Variable 001): The intermediate command
- 4) Fb_PUU (Monitoring Variable 000): The current (feedback) position of motor.
- 5) Err_PUU (Monitoring Variable 002): The position error = (Cmd_O - Fb_PUU).
- 6) In PR mode, at any time (no matter during operation or at stop):
Err_PUU = Cmd_O - Fb_PUU.

Position Commands and Position Registers:

Five different types of position commands: Absolute, Incremental, Stop, Homing and Speed commands.

Type	After position command accepted =>	=> When position command being executed =>	=> When position command is completed
Absolute position command	Cmd_E = command data (absolute) Cmd_O: unchanged DO signal: CMD_OK is OFF	Cmd_E: unchanged Cmd_O continuously output ...	Cmd_E: unchanged Cmd_O = Cmd_E DO signal: CMD_OK is ON
Incremental position command	Cmd_E+= command data (incremental) Cmd_O: unchanged DO signal: CMD_OK is OFF	Cmd_E: unchanged Cmd_O continuously output ...	Cmd_E: unchanged Cmd_O = Cmd_E DO signal: CMD_OK is ON
Stop command DI signal, STP	Cmd_E: unchanged Cmd_O continuously output DO: CMD_OK output unchanged	Cmd_E: unchanged Cmd_O stop in accordance with deceleration curve	Cmd_E: unchanged Cmd_O = position at stop DO signal: CMD_OK is ON
Homing command	Cmd_E: unchanged Cmd_O: unchanged DO signal: CMD_OK is OFF DO signal: HOME is OFF	Cmd_E continuously output Cmd_O continuously output	Cmd_E = Z pulse (absolute position) Cmd_O = position at stop DO signal: CMD_OK is ON DO signal: HOME is ON
Speed command	Cmd_E continuously output Cmd_O continuously output. After speed command is completed, it indicates that the speed reaches the setting value and the motor will not stop. DO signal: CMD_OK is OFF		
Enter PR at the first time (Servo Off-> Servo On or other mode for entering PR mode)		Cmd_O = Cmd_E = current motor feedback position	
Note: The incremental position command performs accumulation according to the end of the position command (Cmd_E). It is irrelevant to current motor position and command timing as well.			

7.8 Homing Function

The homing function determines the homing characteristics of servo motors. The purpose of homing function is used to connect the position of Z pulse of motor encoder to the internal coordinate of the servo drive. The coordinate value corresponds to Z pulse can be specified. After homing operation is completed, the stop position will not locate at the position of Z pulse. This is because the motor must accelerate to stop when Z pulse is found. Generally, the motor stop position will be a little ahead of the position of Z pulse. At this time, Z pulse is set correctly so it will not affect the position precision.

For example:

If the coordinate corresponds to Z pulse is set to 100, after homing operation is completed, $Cmd=300$. It indicates that the acceleration distance is equal to $300-100=200(PUU)$. Since $Cmd_E=100$ (absolute position of Z pulse), if users want to command the motor to return to the position of Z pulse, just set absolute position command to 100 or incremental position command to 0.

In PR mode of ASDA-A2 series, after homing operation, it can execute the specified path and command the motor to return to the position of Z pulse automatically.

When homing function is executed, the software limit function is disabled.

7.9 Triggering PRs

There are several methods to call a PR.

1. Standard

CTRG: Trigger the PR selected by DIs (POS0 ~ POS5).

2. Special

STP: Terminate the running PR.

SHOM: Start to run homing procedure (PR0).

3. Event

EV1 ~ 4 (rising edge): Event can be used to call a PR.

EV1 ~ 4 (falling edge): Event can be used to call a PR.

4. Software

P5-07: Use PR identification to call a PR.

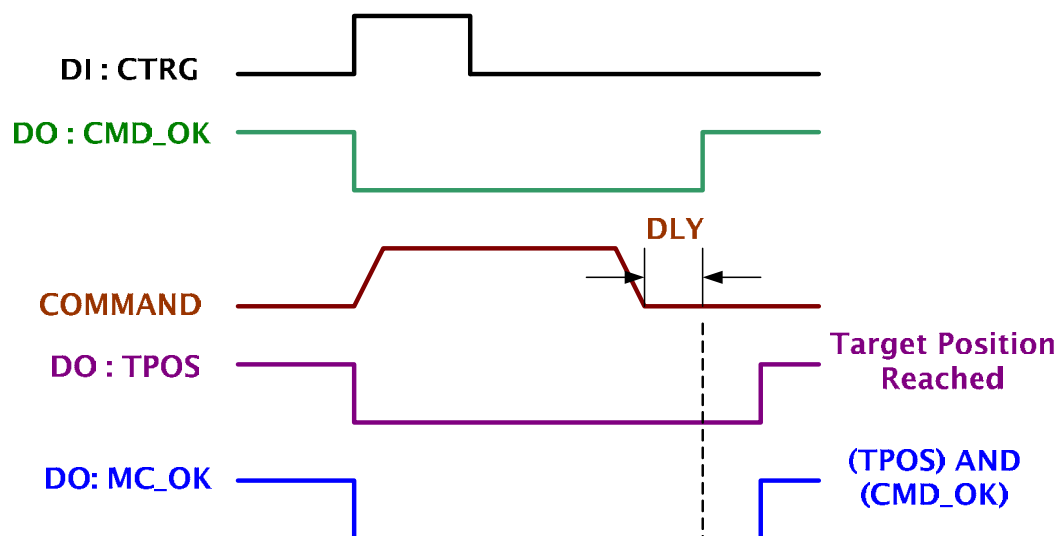
5. Others

PR#50 is called when Capture function finished, and a specific PR can be assigned after E-Cam disengaging.

DI signals: CTRG, SHOM, STP, POS0 ~ POS5, ORG, PL(CCWL), NL(CWL), EV1~4

DO signals: CMD_OK, MC_OK, TPOS, ALRM, CAP_OK, CAM_AREA

Timing chart:



The Ways to Call a PR

There are 64 position settings in PR mode. PR 0 is homing mode and the others (PR 1 ~ 63) can be user-defined. For the ways to call a PR, please refer to the table below:

	Command Source	Explanation
Standard	DI signals: CTRG + POS0 ~ 5	Use DI signals, POS0 ~ 5 to specify the desired trigger procedure number (PR), and then use the rising-edge of DI signal, CTRG to trigger a PR. Suitable application: PC or PLC commands the servo drive by using DI signals
Special	DI signals: STP, SHM	DI signal: Set STP from OFF to be ON, and the command will stop. DI signal: Set SHOM from OFF to be ON, and the servo drive will start to perform homing operation.
Event	DI signals: EV1 ~ 4	There are 4 events with rising and falling edges can be set to trigger a specific PR. DI signals: Trigger the command by changing the status of EV1 ~ 4 P5-98: Event Rising-edge Trigger Command (OFF → ON) P5-99: Event Falling-edge Trigger Command (ON → OFF) Suitable application: sensor, preset trigger procedure
Software	P5-07	Set P5-07 to the desired trigger procedure number (PR) and it will trigger the dedicated position command immediately. P5-07 can be set through the keypad / communication (RS-232/485 and CANopen). Suitable application: PC or PLC commands the servo drive by using the communication. The number from 0 to 63 can be put into P5-07 to call a PR respectively. PR#0 is defined as homing procedure. The P5-07 will reply appropriate message about the result of executing PR.
Others	Trigger the command after Capture operation. Trigger the command after E-Cam is disengaged.	After Capture operation is completed, it will trigger PR 50. This function is enabled by the Bit3 setting of P5-39. After the electronic cam is disengaged, it will return to PR mode and trigger the specified PR designated by BA setting of P5-88. (ASDA-A2 series L type models does not provide this function.)

7.10 Parameter Settings

- 1) Target speed: P5-60 ~ P5-75 (Moving Speed Setting of Position 0 ~ 15), total 16 groups

Bit	15 ~ 0
W0	TARGET_SPEED : 0.1 ~ 6000.0(r/min)

- 2) Accel / Decel time: P5-20 ~ P5-35 (Accel / Decel Time 0 ~ 15), total 16 parameters

Bit	15 ~ 0
W0	T_ACC / T_DEC : 1 ~ 65500(msec)

Note: The acceleration time is used for DO signals, STP/EMS/NL(CWL)/PL(CCWL) when users want to stop the motor. The function of P5-07 will refer to this setting when perform stop positioning as well.

- 3) Delay time: P5-40 ~ P5-55 (Delay Time 0 ~ 15), total 16 groups.

Bit	15 ~ 0
W0	IDLE : 0 ~ 32767(msec)

- 4) PR parameters: P5-00 ~ P5-09, P6-00 ~ P6-01, total 12 DWORD.

	32 BIT
P5-00	Reserved
P5-01	Reserved (for internal testing, do not use it)
P5-02	Reserved (for internal testing, do not use it)
P5-03	Deceleration Time of Protection Function
P5-04	Homing Mode
P5-05	1st Speed Setting of High Speed Homing
P5-06	2nd Speed Setting of Low Speed Homing
P5-07	Trigger Position Command (PR mode only)
P5-08	Forward Software Limit
P5-09	Reverse Software Limit
P6-00	Homing Definition
P6-01	Homing Definition Value (Z pulse position)

- 5) PR Definition: P6-02 ~ P7-27, (64 BIT), total 63 groups (2N)

Bit	31 ~ 28	27 ~ 24	23 ~ 20	19 ~ 16	15 ~ 12	11 ~ 8	7 ~ 4	3 ~ 0
DW0	TYPE
DW1	DATA (32 bit)							

Each PR occupies two parameters. TYPE determines the PR type or function. DATA indicates PR data and the others are auxiliary information.

6) Constant Speed Control: TYPE = 1

Bit	31 ~ 28	27 ~ 24	23 ~ 20	19 ~ 16	15 ~ 12	11 ~ 8	7 ~ 4	3 ~ 0
DW0	-	-	DLY	-	DEC	ACC	OPT	1
DW1	DATA (32 bit): Target speed. Unit: Defined by OPT.UNIT							

When executing this command, the motor will accelerate or decelerate from current speed (the value does not necessarily have to be 0.). Once the motor reach the target speed, it indicates that this command is completed and the motor will continue running in this target speed and will not stop.

OPT:

OPT			
Bit 7	Bit 6	Bit 5	Bit 4
-	UNIT	AUTO	INS

※ When the TYPE is set to 1 ~ 3, it can accept DO signals, STP (Motor Stop), SNL(SCWL, Reverse Software Limit), SPL(SCCWL, Forward Software Limit).

INS: Insertion command on PR

AUTO: When current positioning is completed, the motor moves to the next dedicated PR automatically.

UNIT: 0 ~ 1. 0: Unit is 0.1r/min 1: Unit is PPS(Pulse Per Second)

ACC / DEC: 0 ~ F. Accel / Decel time number (4 bits)

ACC / DEC (4)

Index P5-20 ~ P5-35

SPD: 0 ~ F. Target speed (4 bits)

SPD (4)

Index P5-60 ~ P5-75

DLY: 0 ~ F. Delay time number (4 bits). The digital output of this PR activates after the delay time. External INS is not valid. The delay time number settings correspond with the parameter P5-40 ~ P5-55.

DLY (4)

Index P5-40 ~ P5-55

7) Position Control: (TYPE = 2, Single positioning control. Motor stops when positioning is completed. TYPE = 3: Auto positioning control. Motor goes to next dedicated PR when positioning is completed.)

Bit	31 ~ 28	27 ~ 24	23 ~ 20	19 ~ 16	15 ~ 12	11 ~ 8	7 ~ 4	3 ~ 0
DW0	-	-	DLY	SPD	DEC	ACC	OPT	2 or 3
DW1	DATA (32 bit): Target position, Unit: Pulse of User Unit							

OPT:

OPT				Explanation
Bit 7	Bit 6	Bit 5	Bit 4	
CMD		OVLP	INS	
0	0	-	-	Absolute position command: Cmd_E = DATA (Note 1)
1	0			Incremental position command: Cmd_E = Cmd_E + DATA (Note 2)
0	1			Relative position command: Cmd_E = Current feedback position + DATA (Note 3)
1	1			Capture position command: Cmd_E = Capture position + DATA (Note 4)

※ When the TYPE is set to 1 ~ 3, it can accept DO signals, STP (Motor Stop), SNL(SCWL, Reverse Software Limit), SPL(SCCWL, Forward Software Limit).

INS: Insertion command on PR.

OVLP: Overlap the next PR. This function is not available in speed mode. In position mode, DLY becomes disabled.

CMD: The calculation method for Cmd_E (End of position command) is described in the notes below:

Note 1: The end of position command is an absolute position command which is equal to DATA directly.

Note 2: The end of the position command is an incremental position command which is equal to the end of the position command (Cmd_E, monitor variable 40h) plus a designated DATA.

Note 3: The end of the position command is a relative position command which is equal to current feedback position (monitor variable 00h) plus a designated DATA.

Note 4: The end of the position command is a capture position command which is equal to capture position (monitor variable 2Bh) plus a designated DATA.

8) Special Function: TYPE = 7. Jump to the dedicated PR.

Bit	31 ~ 28	27 ~ 24	23 ~ 20	19 ~ 16	15 ~ 12	11 ~ 8	7 ~ 4	3 ~ 0
DW0	-	-	DLY	-	FUNC_CODE	OPT	7	-
DW1	PR Number (0 ~ 63)							

OPT:

OPT			
Bit 7	Bit 6	Bit 5	Bit 4
-	-	-	INS

PR Number: Dedicated jump PR

FUN_CODE: Reserved

DLY: Delay time after jump

9) Special Function: TYPE = 8 , Write the specified parameter to the dedicated PR.

Bit	31 ~ 28	27 ~ 24	23 ~ 20	19 ~ 16	15 ~ 12	11 ~ 8	7 ~ 4	3 ~ 0
DW0	-	-	DLY	P_Grp	P_Idx	OPT	8	-
DW1	Para_Data							

P_Grp, P_Idx: Parameter group and number

DLY: Delay time after writing the parameters

OPT :

OPT			
Bit 7	Bit 6	Bit 5	Bit 4
-	-	AUTO	INS

Para_Data: Write data

Please note:

1. For the firmware version V1.013 and earlier models:

If the values of the parameters can be retained when power is off, the new setting values will be written into EEPROM. Please note that do not frequently write data into EEPROM as doing this may damage EEPROM.

2. For the firmware version V1.013 and later models:

Even if the values of the parameters can be retained when power is off, the new setting values will not be written into EEPROM. Do not worry that EEPROM may be damaged.

Note:

Writing the specified parameter to the dedicated PR is used for the applications which need On/Off operation or tuning function. For example, it can be used when using P2-00 for different position commands). Usually, On/Off operation or tuning function will not be executed for one time only. They are usually executed for many times repeatedly during the operation of the mechanical system. If users write all the data into EEPROM too frequently, it may damage EEPROM. When setting P2-30 to 5, the data will not retained when power is off. But this is not convenient for users to use. In order to solve this problem, ASDA-A2 series adds this function.

3. If the operation of writing parameter to the dedicated PR is failed, the fault AL213 ~ AL219 will occur (see Chapter 11 Troubleshooting). If any fault occurs, the motor will not move to the next dedicated PR automatically when current positioning is completed.

10) Homing Definition: P6-00 ~ P6-01, (64 bits), total 1 group.

Bit	31 ~ 28	27 ~ 24	23 ~ 20	19 ~ 16	15 ~ 12	11 ~ 8	7 ~ 4	3 ~ 0
DW0	BOOT	-	DLY	DEC2	DEC1	ACC	PR	BOOT
DW1	ORG_DEF (32 bit)							

PR: 0 ~ 3F. PR style (4 bits)

0: Stop mode. Motor stops after homing is completed.

1~63 (01 ~ 3F): Auto mode. Motor goes the dedicated PR 1 ~ 63 after homing is completed.

ACC: Acceleration time

DEC1 / DEC2: 1st deceleration time / 2nd deceleration time..

DLY: Delay time

BOOT: Boot mode. Disable or enable homing function when the servo drive is applied to power (power on).

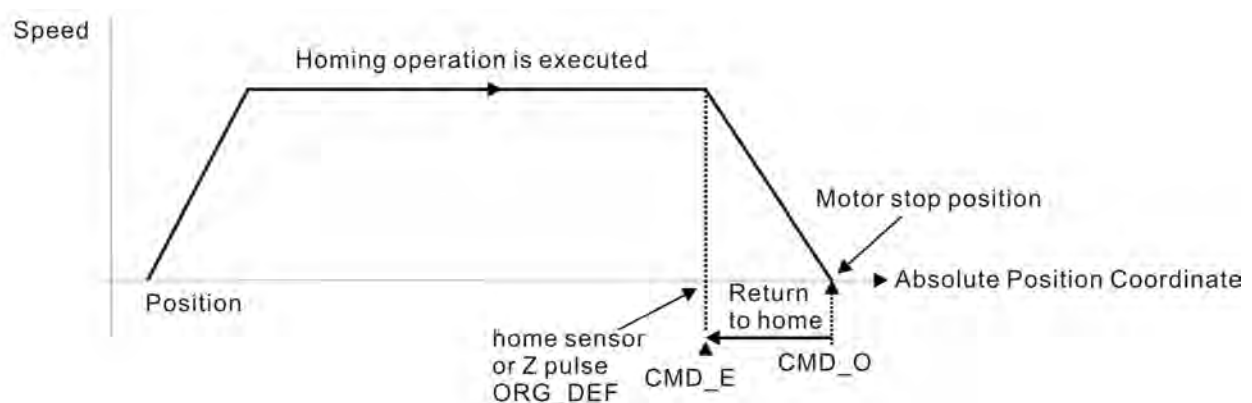
0: Disable homing function

1: Enable homing function (when the servo drive is applied to power, first time Servo On)

ORG_DEF: Homing definition value which is determined by the parameter P6-01. The homing definition value does not necessarily have to be 0.

1) ASDA-A2 series does not provide the functions that find Z pulse and regard Z pulse as "Home". Therefore, it needs to decide if the motor return to Z pulse position when homing operation is completed.

After home sensor or Z pulse is found, the motor must accelerate to stop. Generally, the motor stop position will be a little ahead of the position of Z pulse.



Do not return to Z pulse: Set PR=0

Return to Z pulse: Set PR=a non-zero value and set absolute position command= ORG_DEF.

CMD_O : Command Output Position

CMD_E : Command End Position

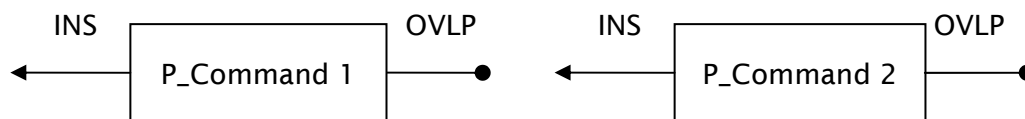
2) Position offset values are not defined when performing homing operation. After homing operation, the position offset values can be set as a dedicated PR.

For example, if users want the motor to move a distance S (relative to home sensor or Z pulse), and defined the position coordinate as P, set PR as a non-zero value and set $ORG_DEF=P - S$.

(P is the absolute position command and S is the incremental position command)

7.10.1 Motion Commands

1) Each motion command can be inserted (INS) or overlapped (OVLP).



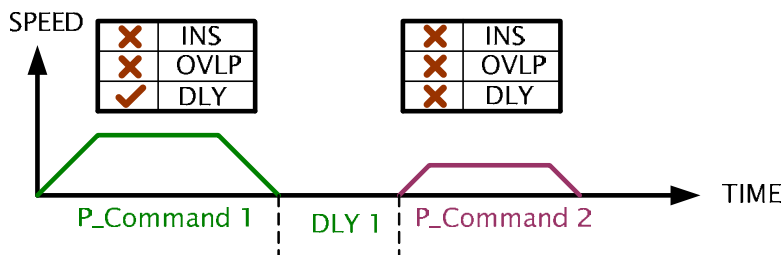
2) The priority of INS is higher than OVLP.

P_Command 1	P_Command 2	Sequence	Output	Note
OVLP=0	INS=0	Sequential Command	DLY 1	P_Command 1 and P_Command 2 can be speed or position command.
OVLP=1	INS=0	Overlap Command	NO DLY	When P_Command 2 is a speed command, OVLP function is disabled.
OVLP=0	INS=1	Insertion Command	N/A	P_Command 1 and P_Command 2 can be speed or position command.
OVLP=1				

7.10.2 Sequence

1) Sequential Command on PR

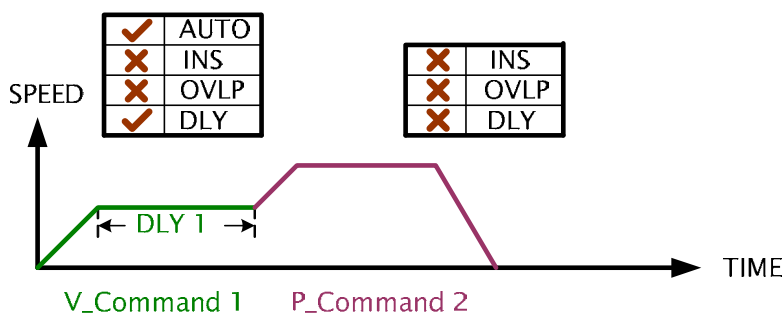
A command will be executed only when the previous command completed.



P_Command 1: DLY is set

P_Command 2: INS is not set

(DLY: Delay time is calculated from the time when the position command is completed)



V_Command 1: Speed command. DLY is set

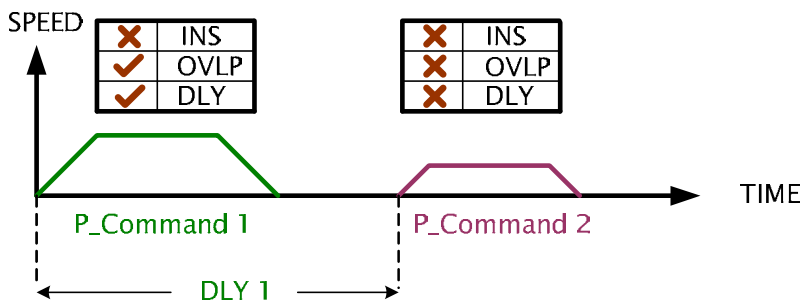
P_Command 2: Position command.

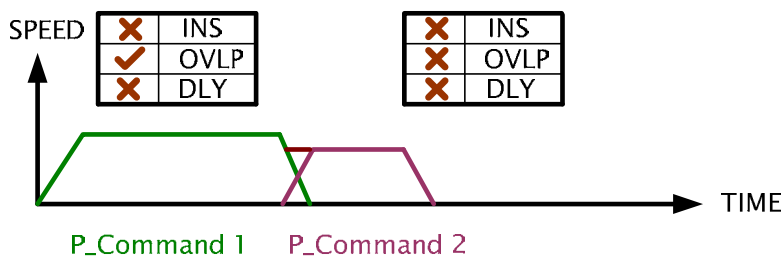
(DLY: Delay time is calculated from the time when the position command is completed)

2) Overlap Command

The second command will be executed after delay time or during deceleration period.

A long delay time at the first command will affect the timing of second command. Zero delay is recommended for overlap application.



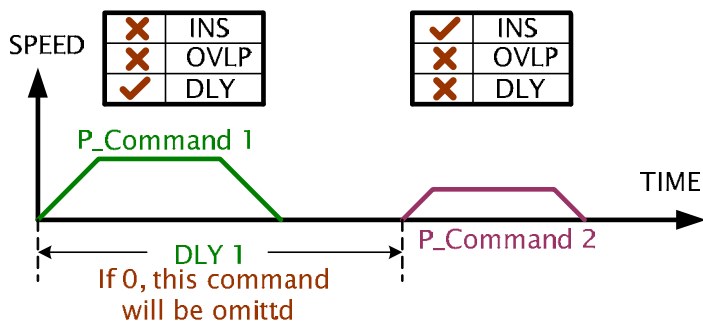


P_Command 1: OVL is set, DLY can not be set.

P_Command 2: INS is not set

3) Internal Insertion Command

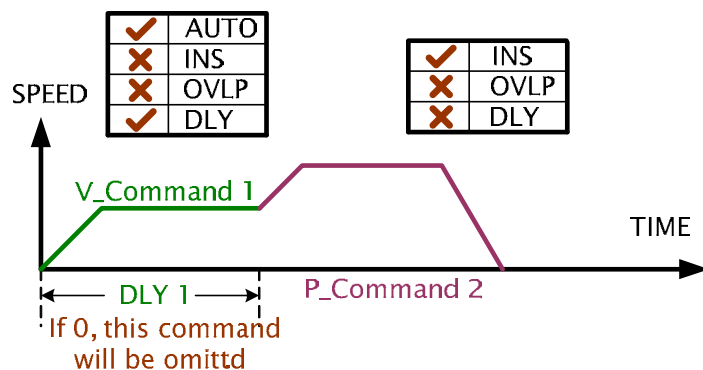
The second command will insert the first command to be a new command. The final result depends on the types of commands. The delay time gets function.



The final destination :

Absolute : $Cmd_E = command$

Relative, Incremental:
 $Cmd_E = last\ Cmd_E + command$



The final destination :

Absolute : $Cmd_E = command$

Relative, Incremental:
 $Cmd_E = last\ Cmd_E + command$

V_Command 1: Speed Command. DLY is set

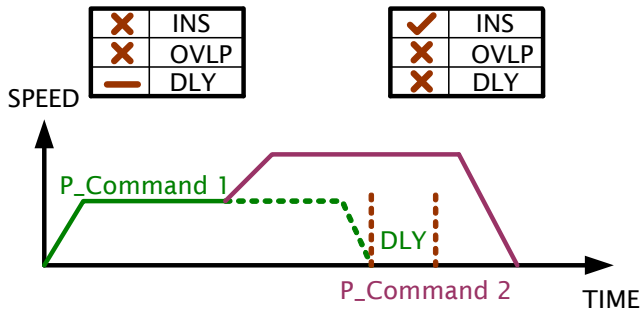
P_Command 2: Position Command. INS is set

(DLY is valid for internal insertion command)

This procedure can be used to create complicated position profile.

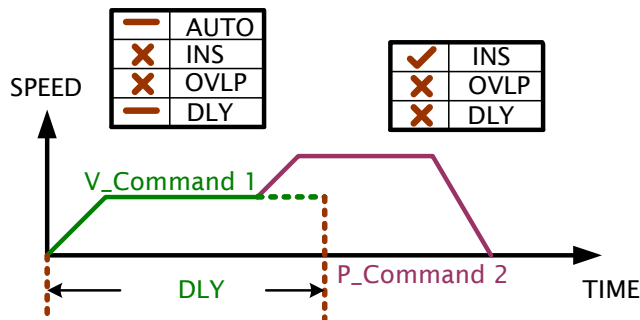
4) External Insertion Command

The external insertion will change the command being executed at the moment it inserted. The delay time is not a matter for external insertion.



The final destination :

- Absolute : $Cmd_E = command$
- Relative : $Cmd_E = Fb_PUU + command$
- Incremental : $Cmd_E = last\ Cmd_E + command$
- Cap. Relative : $Data\ captured + command$



The final destination :

- Absolute : $Cmd_E = command$
- Relative : $Cmd_E = Fb_PUU + command$
- Incremental : $Cmd_E = last\ Cmd_E + command$
- Cap. Relative : $Data\ captured + command$

V_Command 1: Speed Command. The delay time is not a matter for external insertion.

P_Command 2: Position Command. INS is set

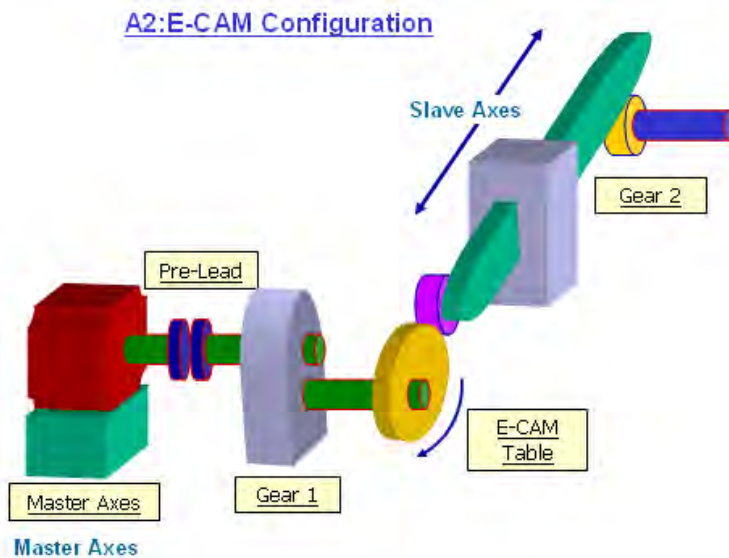
(DLY is not valid for external insertion command)

This procedure can be used to change position profile freely.

7.11 Electronic Cam (E-Cam) (ASDA-A2 series L type models does not provide this function)

From Machine Cam to Electronic Cam

The concept of electronic cam (E-Cam) is to use the software settings to determine the position relationship between master axis (Master) and slave axis (Slave), almost like a virtual electronic cam exists between both of them. Please refer to the figure below.



In PT mode, the external input pulse number (from master axis) is the reference of the position command (from slave axis). It indicates the slave axis follows the master axis. The relationship between master axis and slave axis is a linear relationship (The ratio is electronic gear ratio). When the electronic cam function is enabled, the relationship between master axis and slave axis is no longer a linear relationship only. It will become a cyclic curve relationship, just like the profile of the electronic cam. In the traditional mechanical system, a machine cam (physical cam) can convert the simple constant speed motion to variable speed motion, reciprocating motion and intermittent motion, etc. a wide range of motion control operation. The electronic cam can provide the same function and make the system to be used for a variety of motion control applications as well.

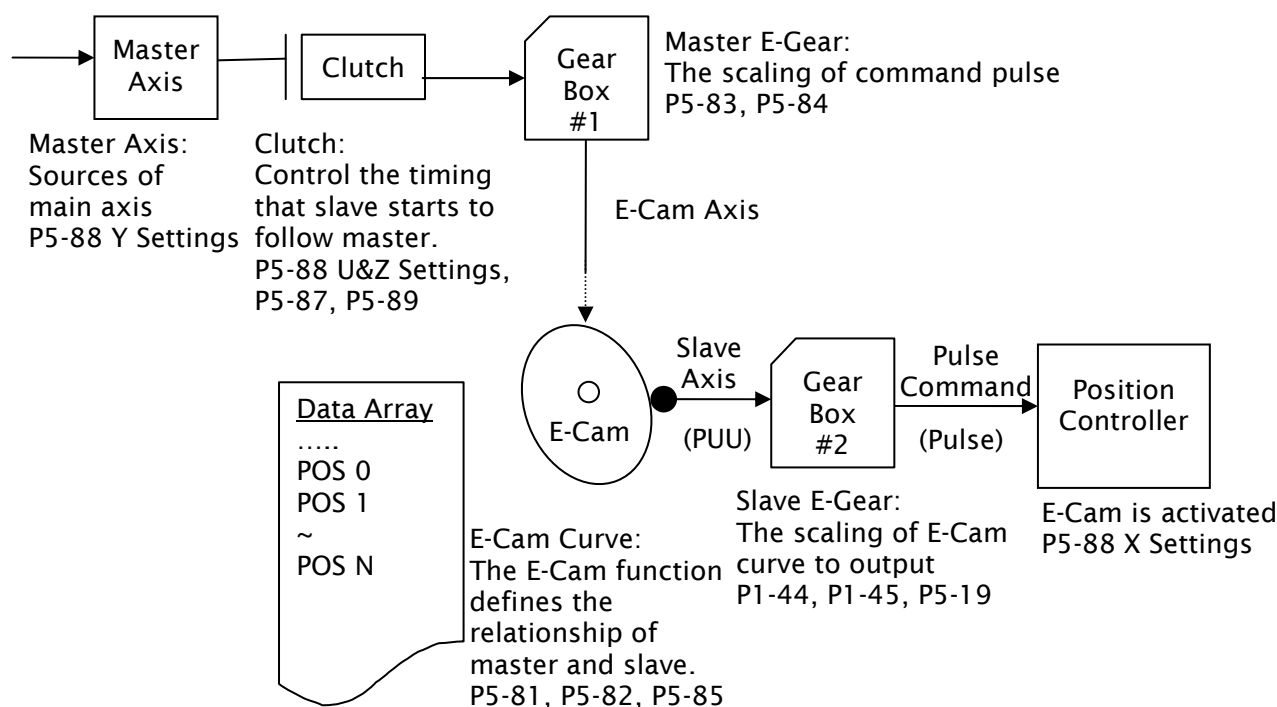
Please refer to the table below to know the differences between a machine cam (physical cam) and an electronic cam (virtual cam).

	Machine Cam (Physical Cam)	Electronic Cam
Structure	Return to the original position after one rotation.	After E-Cam rotates 360 degrees (one revolution), it can return to the original position and also can display by spiral form like mosquito coil incense.
Smooth Performance	Determined by actual process precision	Three curves can be interpolated between two positions upon software.
Position Accuracy	The position accuracy is very precise (under the condition of no vibration)	The position accuracy is very precise, but the actual motor position will be a little deviated due to the delay time.
Long Distance Motion	When the motion distance is longer, the system needs bigger machine cam. Making a big machine cam is not easy.	Only need to change the values of E-Cam curve. It is applicable for the application of long motion distance.
If master axis can be eliminated	Master axis can not be eliminated	Master axis can be eliminated for constant speed motion application. Users can use the signals that generated by the servo drive.
Replacement	Need of replacement or repair. It will cost money.	No need of replacement or repair. Users only need to reset the parameter settings.
Maintenance	Machine will wear. Maintenance is necessary.	Maintenance is not necessary.
Other	Mater axis will occupy the space and consume the power.	Space and energy saving. Good for environmental protection.

■ Characteristics of E-Cam:

Characteristics of E-Cam	
Control Mode	E-Cam function is available only in PR mode.
Enable E-Cam Function (P5-88 X Settings)	X=0: Disable E-Cam function (Default). If E-Cam has been engaged already, setting X=0 will force E-Cam to be disengaged. X=1 : Enable E-Cam function.
States of E-Cam	There are three statuses: Stop / Lead Pulse / Engaged
Sources of Master Axis (P5-88 Y Settings)	<ul style="list-style-type: none"> ● Physical axes: <ul style="list-style-type: none"> ■ P5-88 Y=1. Linear Encoder (CN5) ■ P5-88 Y=2. Pulse Command (CN1) ● Output axis: <ul style="list-style-type: none"> ■ P5-88 Y=0. Capture source setting. (Defined by Capture function, P5-39 B settings) ● Virtual axes: <ul style="list-style-type: none"> ■ P5-88 Y=3. PR command (Internal signal) ■ P5-88 Y=4. 1 ms clock (Internal signal) ■ P5-88 Y=5. Synchronous Capture Axis (P5-39 B, Mark tracking)
Servo Drive Command	<p>Servo drive command = E-Cam command + PR command</p> <ul style="list-style-type: none"> ● The command will be sent only when E-Cam is engaged. ● No matter E-Cam is engaged or not, PR command is valid. Only when E-Cam is engaged, the source of master axis is PR command and PR command is set to 0. <p>When E-Cam operates, users can adjust E-Cam position through PR command still (usually using incremental position command).</p>
Data Storage Location	<ul style="list-style-type: none"> ● Data array. The E-Cam curve is stored in the data array. P5-81 notes its start point where P5-82 +1 (720+1, maximum items of one E-Cam curve) is for its length. P5-85 is the initial point where the E-Cam engaged.
E-Cam Curve Division	<ul style="list-style-type: none"> ● It is set by P5-82. Range: 5 ~ 720
Data Format	<ul style="list-style-type: none"> ● 32-bit data with polarity
Data Content	<ul style="list-style-type: none"> ● Save the position of slave axis (user unit: PUU)
Calculation Method of E-Cam Position	<ul style="list-style-type: none"> ● Pulses of E-Cam master axis output incrementally → E-Cam Axis ● Pulses of E-Cam slave axis output incrementally → Position Command ● After E-Cam rotates one revolution, the slave axis may not return to the original position definitely. The position of the slave axis is determined by the content of E-Cam curve. ● Three curves can be interpolated between two positions upon software. The adjacent curves at the ends continue quadratic differential equation and make the torque of the ends to be smooth.
DO signal: CAM_AREA (DO=0x18)	<ul style="list-style-type: none"> ● DO signal : CAM_AREA. When CAM_AREA is activated, it indicates that the servo drive has detected the E-Cam master position is within the setting area.

The function block diagram of E-Cam is shown as the figure below:



■ Function of Master Axis

Function of Master Axis	
Descriptions	The movement of the master axis is the signal which enables E-Cam operation of the servo drive.
Source of Master Axis (P5-88 Y Settings)	<p>The command source of the master axis is determined by P5-88 Y settings.</p> <ul style="list-style-type: none"> ● Physical axes: <ul style="list-style-type: none"> ■ P5-88 Y=1. Linear Encoder (CN5) ■ P5-88 Y=2. Pulse Command (CN1) ● Output axis: <ul style="list-style-type: none"> ■ P5-88 Y=0. Capture source setting. (Defined by Capture function, P5-39 B settings) ● Virtual axes: <ul style="list-style-type: none"> ■ P5-88 Y=3. PR command (Internal signal) ■ P5-88 Y=4. 1 ms clock (Internal signal) ■ P5-88 Y=5. Synchronous Capture Axis (P5-39 B, Mark tracking)
Position of Master Axis (P5-86)	Using P5-86 can monitor the position of the master axis. Before E-Cam is engaged, P5-86 can be set and changed still. Doing this will not affect the position of the slave axis because the movement of the master axis does not change as well. When the E-Cam is activated (P5-88 X=1), the pulse will be counted in P5-86. The P5-86 should be an increasing number. If not, reverse the pulse direction (not motor direction).

■ Function of Clutch

Function of Clutch	
Descriptions	<p>This function is used to determine the engaging and disengaging state of the master axis and gear box # 1.</p> <p>After E-Cam is engaged, then the movement of the master axis is able to rotate E-Cam of the servo drive.</p>
Enable E-Cam Function (P5-88 X Settings)	<p>X=0: Disable E-Cam function (Default). If E-Cam has been engaged already, setting X=0 will force E-Cam to be disengaged.</p> <p>X=1: Enable E-Cam function.</p>
States of E-Cam	<p>There are three statuses: Stop / Lead Pulse / Engaged</p> <div style="text-align: center;"> <pre> graph TD S0((S0 Stop)) -- 1 The condition set in P5-88 Z setting is satisfied The lead pulse number is set in P5-87 --> S2((S2 Lead Pulse)) S2 -- 2 P5-88 X=0 --> S0 S2 -- 3 The lead pulse number set in P5-87 or P5-92 reached Can be read from monitoring variable 061 --> S1((S1 Engaged)) S1 -- 4 P5-88 U=4 The lead pulse number is set in P5-92 --> S2 S1 -- 5 P5-88 X=0 P5-88 U=1, 2, 6 --> S0 </pre> </div> <p><u>States of E-Cam</u></p> <p>There are 3 states to indicate the status of the E-Cam system.</p> <ul style="list-style-type: none"> ● Stop This is the default status of E-Cam. E-Cam will not operate in accordance with the pulses of the master axis. When E-Cam function is disabled (P5-88 X=0), E-Cam will return to this state. ● Lead Pulse When the engaging conditions are satisfied (Path 1), the status of E-Cam will change to Lead Pulse. At this time, E-Cam will not operate in accordance with the pulses of the master axis. ● Engaged When the lead pulse number set in P5-87 or P5-92 reached (Path 3), E-Cam will enter into Engaged state and start to operate in accordance with the pulses of the master axis. <p><u>Path Explanation</u></p> <ul style="list-style-type: none"> ● Path 1 When the engaging conditions are satisfied (P5-88 Z setting), the status of E-Cam will change from Stop to Lead Pulse. The lead pulse number is set in P5-87.

Function of Clutch	
States of E-Cam	<ul style="list-style-type: none"> ● Path 2 When E-Cam function is disabled (P5-88 X=0), the status of E-Cam will return to Stop. ● Path 3 When the lead pulse number set in P5-87 or P5-92 reached, , the status of E-Cam will change from Lead Pulse to Engaged. ● Path 4 When disengaging conditions are satisfied (P5-88 U=4), the status of E-Cam will change from Engaged to Lead Pulse. When the electronic gear is disengaged, the status of E-Cam will not change to Stop. It will change to Lead Pulse and the lead pulse number at this time is set in P5-92 (this function is only available for the firmware version V1.006sub04 and later models). ● Path 5 When disengaging conditions are satisfied (P5-88 U=1, 2, 6), or when E-Cam function is disabled (P5-88 X=0), the status of E-Cam will change from Engaged to Stop.
Engaging Conditions (P5-88 Z Settings)	<p>When E-Cam is in the status of Stop, this function is used to determine the engaging timing (Path 1).</p> <p>Three conditions to engage the clutch:</p> <p>Z=0: Engage immediately when E-Cam function is enabled (When P5-88 X=1)</p> <p>Z=1: Engage when DI signal, CAM (DI=0x36) is ON.</p> <p>Z=2: Any action of Capture function. E-Cam engaged after the next position is captured.</p> <p>The Capture function is designed to activate E-Cam because of its high speed input. When the Capture function fetches the position, it will bring the E-Cam function enforcement simultaneously. Because the Capture operation is controlled by external control command (hardware), and no delay occurs, this setting is suitable for the application requires real time such as the master axis is already operating before E-Cam is engaged.</p>
Lead Pulse Number (Monitoring Variable 061)	<ul style="list-style-type: none"> ● When E-Cam is in the status of Lead Pulse, the master axis needs to move for a certain distance and then E-Cam is able to be engaged (Path 3). This movement is called as Lead Pulse Number and it can be monitored by the monitoring variable 061. The value of lead pulse number will descend according to the input pulses of the master axis. When the value of lead pulse number becomes 0, the status of E-Cam will change to Engaged. ● When the status of E-Cam changes to Lead Pulse by Path 1, the lead pulse number is set in P5-87. ● When the status of E-Cam changes to Lead Pulse by Path 4, the lead pulse number is set in P5-92. ● If the setting value of P5-87 and P-92 is 0, it indicates that there is no lead pulse number and the status of E-Cam will change to Engaged immediately. <p>+ / - signs indicates the direction of lead pulse. Please note that if the polarity of the direction of lead pulse is set incorrectly, E-Cam will not be engaged.</p>

Function of Clutch																						
Lead Pulse Number (Monitoring Variable 061)	When the direction of lead pulse is not set correctly, it will cause that the value of the monitoring variable 061 becomes higher and higher and finally lead to overflow. At this time, E-Cam function will be disabled (P5-88 X=0) and the status of E-Cam will be forced to be changed to Stop .																					
Disengaging Timing (P5-88 U Settings)	<p>This option is used to determine the disengaging timing when the status of E-Cam is Engaged. Please note that the condition 2, 4, and 6 are mutually exclusive; that is, only one of them can be selected.</p> <table border="1"> <thead> <tr> <th>U</th> <th>Disengaging Conditions</th> <th>States of E-Cam when disengaging</th> </tr> </thead> <tbody> <tr> <td>0</td> <td>Do not disengage. When P5-88 X=0, E-Cam disengaged.</td> <td>(Path 5) Change to the status of Stop</td> </tr> <tr> <td>1</td> <td>Disengage when DI signal, CAM (DI=0x36) is OFF.</td> <td>(Path 5) Change to the status of Stop</td> </tr> <tr> <td>2</td> <td>Fixed number of master pulses (P5-89) to disengage. (The polarity sign indicates the direction)</td> <td>(Path 5) Change to the status of Stop</td> </tr> <tr> <td>6</td> <td>(This setting is only available in firmware V1.009 and later models) Fixed number of master pulses (P5-89) to disengage for smooth speed. The function is the same as the setting of U=2. The difference is that the speed will not change when disengaging and the engaging length will exceed the setting value of P5-89 a little. This setting is suitable for the application which needs to use PR command immediately when disengaging.</td> <td>(Path 5) Change to the status of Stop</td> </tr> <tr> <td>4</td> <td>(This setting is only available in firmware V1.009 and later models) Fixed number of master pulses (P5-89) to disengage with cycle function. (The polarity sign indicates the direction)</td> <td>(Path 4) Return to the status of Lead Pulse (before engaging) (The lead pulse number is set in P5-92).</td> </tr> <tr> <td>8</td> <td>Shut down E-Cam when disengaging.</td> <td>P5-88 X=0</td> </tr> </tbody> </table>	U	Disengaging Conditions	States of E-Cam when disengaging	0	Do not disengage. When P5-88 X=0, E-Cam disengaged.	(Path 5) Change to the status of Stop	1	Disengage when DI signal, CAM (DI=0x36) is OFF.	(Path 5) Change to the status of Stop	2	Fixed number of master pulses (P5-89) to disengage. (The polarity sign indicates the direction)	(Path 5) Change to the status of Stop	6	(This setting is only available in firmware V1.009 and later models) Fixed number of master pulses (P5-89) to disengage for smooth speed. The function is the same as the setting of U=2. The difference is that the speed will not change when disengaging and the engaging length will exceed the setting value of P5-89 a little. This setting is suitable for the application which needs to use PR command immediately when disengaging.	(Path 5) Change to the status of Stop	4	(This setting is only available in firmware V1.009 and later models) Fixed number of master pulses (P5-89) to disengage with cycle function. (The polarity sign indicates the direction)	(Path 4) Return to the status of Lead Pulse (before engaging) (The lead pulse number is set in P5-92).	8	Shut down E-Cam when disengaging.	P5-88 X=0
	U	Disengaging Conditions	States of E-Cam when disengaging																			
	0	Do not disengage. When P5-88 X=0, E-Cam disengaged.	(Path 5) Change to the status of Stop																			
	1	Disengage when DI signal, CAM (DI=0x36) is OFF.	(Path 5) Change to the status of Stop																			
	2	Fixed number of master pulses (P5-89) to disengage. (The polarity sign indicates the direction)	(Path 5) Change to the status of Stop																			
	6	(This setting is only available in firmware V1.009 and later models) Fixed number of master pulses (P5-89) to disengage for smooth speed. The function is the same as the setting of U=2. The difference is that the speed will not change when disengaging and the engaging length will exceed the setting value of P5-89 a little. This setting is suitable for the application which needs to use PR command immediately when disengaging.	(Path 5) Change to the status of Stop																			
	4	(This setting is only available in firmware V1.009 and later models) Fixed number of master pulses (P5-89) to disengage with cycle function. (The polarity sign indicates the direction)	(Path 4) Return to the status of Lead Pulse (before engaging) (The lead pulse number is set in P5-92).																			
8	Shut down E-Cam when disengaging.	P5-88 X=0																				
Auxiliary Function (P5-88 BA Settings)	Call PR defined in P5-88 BA settings when disengaging (only when P5-88 U=2, 4, or 6 is selected). When E-Cam returns to the status of Stop , the designated PR defined in P5-88 BA settings will be executed immediately.																					

■ Function of Gear Box #1 (Master E-Gear)

Function of Gear Box #1 (Master E-Gear)	
Function	<ul style="list-style-type: none"> ● This function defines the relationship of the master axis and E-Cam axis. When the master axis rotates one revolution, it does not mean that E-Cam must rotate one revolution as well. The master E-Gear can be set. ● The master E-Gear (electronic gear) will change the resolution of master pulse command.
Explanation	<ul style="list-style-type: none"> ● E-Cam axis is a virtual axis. ● When E-Cam axis rotates 360 degrees, it indicates that E-Cam rotates one revolution also and the slave axis operates one cycle as well. ● The moving unit of the master axis is pulse number. The resolution is determined by the command source.
Setting Method P5-83 : M P5-84 : P	<ul style="list-style-type: none"> ● P5-83 and P5-84 is used to set the scaling of command pulse. After receiving the pulse number P of master axis, the axis of E-Cam will rotate M cycles. $P5-83=M$, $P5-84=P$ ● P5-83 can be adjusted while engaging.

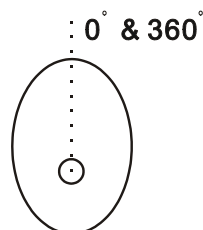
■ Function of E-Cam Curve

Function of E-Cam Curve	
Function	<ul style="list-style-type: none"> ● The E-Cam function defines the relationship of master and slave axes. The related settings are saved in E-Cam curve. When E-Cam rotates one revolution, the slave axis operates one cycle.
Data Storage Location	<ul style="list-style-type: none"> ● Data array. The E-Cam curve is stored in the data array. P5-81 notes its start point where $P5-82 + 1$ (720+1, maximum items of one E-Cam curve) is for its length. P5-85 is the initial point where the E-Cam engaged.
Data Format	<ul style="list-style-type: none"> ● 32-bit data with polarity (user unit is PUU)
E-Cam Curve Scaling P5-19 (-2147.000000 ~ 2147.000000)	<ul style="list-style-type: none"> ● It is used to magnify or minify E-Cam curve without changing the setting value of the E-Cam curve. ● Each data in E-Cam curve can be multiplied by this parameter. ● Range of P5-19 is: -2147.000000 ~ 2147.000000 with minimum scale of 0.000001. The change of P5-19 will be put into enforcement when the E-Cam re-engaged. ● E-Cam curve can be a negative scaling. If P5-19 is set to negative, the result will have a upside down curve compared to P5-19 is a positive value. ● When it is set to 0, E-Cam command will not output (always be 0).
E-Cam Curve Division N	<ul style="list-style-type: none"> ● E-Cam curve can be divided into certain equal N parts (set by P5-82, $N \geq 5$). For example, if $N=5$, there will be 6 points recorded in the data array. Each division has $360/N$ degrees. ● 720 divisions are maximum number for one curve.

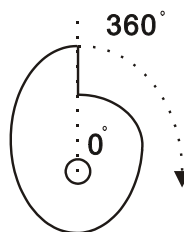
Function of E-Cam Curve

- E-Cam curve saves the position data of slave axis (user unit is PUU).
- If E-Cam is divided into N parts, it means that total N+1 points are recorded in the data array. This is because the position of the first point (0°) and the position of the last point (360°) are not the same.

1. When the positions of 0° and 360° are the same:

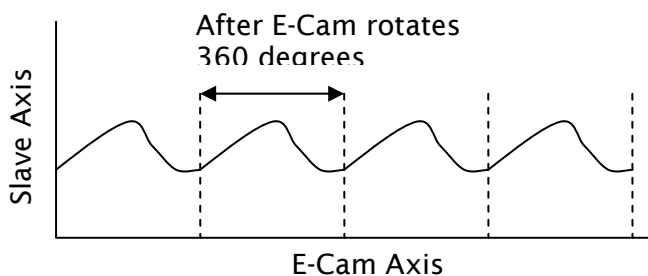


2. When the positions of 0° and 360° are not the same:

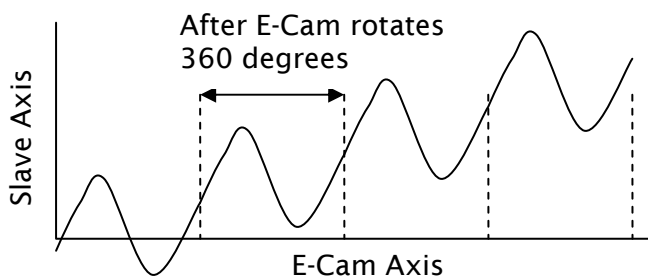


E-Cam Curve Content

- Suppose that:
 1. When the positions of 0° and 360° are the same:
It indicates that the position of slave axis will return to home after E-Cam rotates 360° (one revolution).



2. When the positions of 0° and 360° are not the same:
It indicates that the position of slave axis will not return to home after E-Cam rotates 360° (one revolution).



Function of E-Cam Curve	
Operation	<ul style="list-style-type: none"> ● Slave axis is a virtual axis (user unit is PUU). ● P5-85 is the first point where the E-Cam engaged. When E-Cam engaged, the position of E-Cam axis will move to the point set by P5-85. The position of slave axis will move to the position which corresponds to P5-85. ● After E-Cam engaged, if E-Cam axis does not move, the slave axis will not move either. After E-Cam engaged, if E-Cam moves, the position changes of E-Cam axis represent the output pulses of the slave axis. ● When E-Cam rotates 360 degrees (one revolution), the slave axis operates one cycle. ● E-Cam axis can rotate in either forward or reverse direction. ● If the position of E-Cam axis is between two points of E-Cam curve, the position of the slave axis can be interpolated by cubic curves and the adjacent curves at the ends will continue quadratic differential equation and make the torque of the ends to be smooth. The point number of E-Cam curve will not affect the smooth operation of E-Cam either.

■ Function of Gear Box #2 (Slave E-Gear)

Function of Gear Box #2 (Slave E-Gear)	
Function	<ul style="list-style-type: none"> ● This function defines the relationship of slave axes and pulse command. ● When the slave axis rotates one revolution, it does not mean that pulse command must rotate one revolution as well. The slave E-Gear can be set.
Explanation	<ul style="list-style-type: none"> ● Slave axis is a virtual axis (user unit is PUU). ● The unit of pulse command is encoder unit, pulse (1280000 pulse/rev) ● When E-Cam axis rotates one revolution, the slave axis operates one cycle as well.
Setting Method P1-44: Numerator of Electronic Gear Ratio P1-45: Denominator of Electronic Gear Ratio	<ul style="list-style-type: none"> ● When the pulse command of slave axis is L and motor runs R rotation, the electronic gear ratio will be equal to $P1-44/P1-45 = 1280000 \times R/L$ ● The function is the same as the electronic gear ratio in PT and PR mode.

■ Digital Outputs for E-Cam Function

Digital Outputs for E-Cam Function	
Digital Outputs	<ul style="list-style-type: none"> ● DO signal: CAM_AREA (DO=0x18)
Function	<ul style="list-style-type: none"> ● When DO signal, CAM_AREA is ON, it indicates that the position of E-Cam axis is within the specified angle range.
When E-Cam engaged	<ul style="list-style-type: none"> ● Degree when P5-90 and P5-91 is set to ON ● See Table 1 & 2 below.
When E-Cam disengaged	<ul style="list-style-type: none"> ● DO signal: CAM_AREA are OFF

Table 1 P5-90 ≤ P5-91:

E-Cam Degree	0°	~	P5-90	~	P5-91	~	360°
DO:CAM_AREA	OFF	OFF	ON	ON	ON	OFF	OFF

Table 2 P5-90 > P5-91:

E-Cam Angle	0°	~	P5-91	~	P5-90	~	360°
DO:CAM_AREA	ON	ON	OFF	OFF	OFF	ON	ON

7.11.1 Capture Function

The Capture function can be applied to latch a reference position which could be the signal of main encoder, linear encoder, or pulse train. It is possible to record 800 items with max. length of data array.

The DI7 is the only one high speed digital input in ASDA-A2. The Capture function needs DI7 to admit the signal changed in real time. The signal to DI7 for Capture function is a physical signal and cannot be simulated from software. It can complete precise Capture function for high-speed motion axis.

The characteristics of Capture function is described as follows:

Characteristics of Capture function	
Sources	<p>Three sources of Capture function:</p> <ul style="list-style-type: none"> ● Main encoder: Motor encoder ● Auxiliary encoder: Linear scale ● Pulse command: Pulse train <p>The selected source axis will be displayed by P5-37. Before executing Capture function, please set P5-37 first.</p> <p>Please note:</p> <p>The capture source setting can not be changed when the compare source is the capture axis.</p>
Trigger Signal	<ul style="list-style-type: none"> ● It is triggered by DI7 and the response time is 1 usec. <p>Please note:</p> <p>DI7 signal is a physical signal used to control Capture function directly. No matter what the setting value of P2-16 is, when DI7 is triggered, Capture function will be enabled always. After Capture function is enabled, in order to avoid the malfunction of the other DI signals, the system will force the other DI signals to be disabled, i.e. set P2-16=0x0100 automatically. Please note that the setting value of P2-16 will not be written into EEPROM when power is off. After re-power the servo drive, the setting value of P2-16 will be restored to its default setting automatically.</p>
Trigger Method	<ul style="list-style-type: none"> ● By edge triggered. A or B contact can be selectable. ● It is able to capture multiple positions continuously. ● The interval time can be set also. (It can determine how long it will take when accepting the next trigger command)

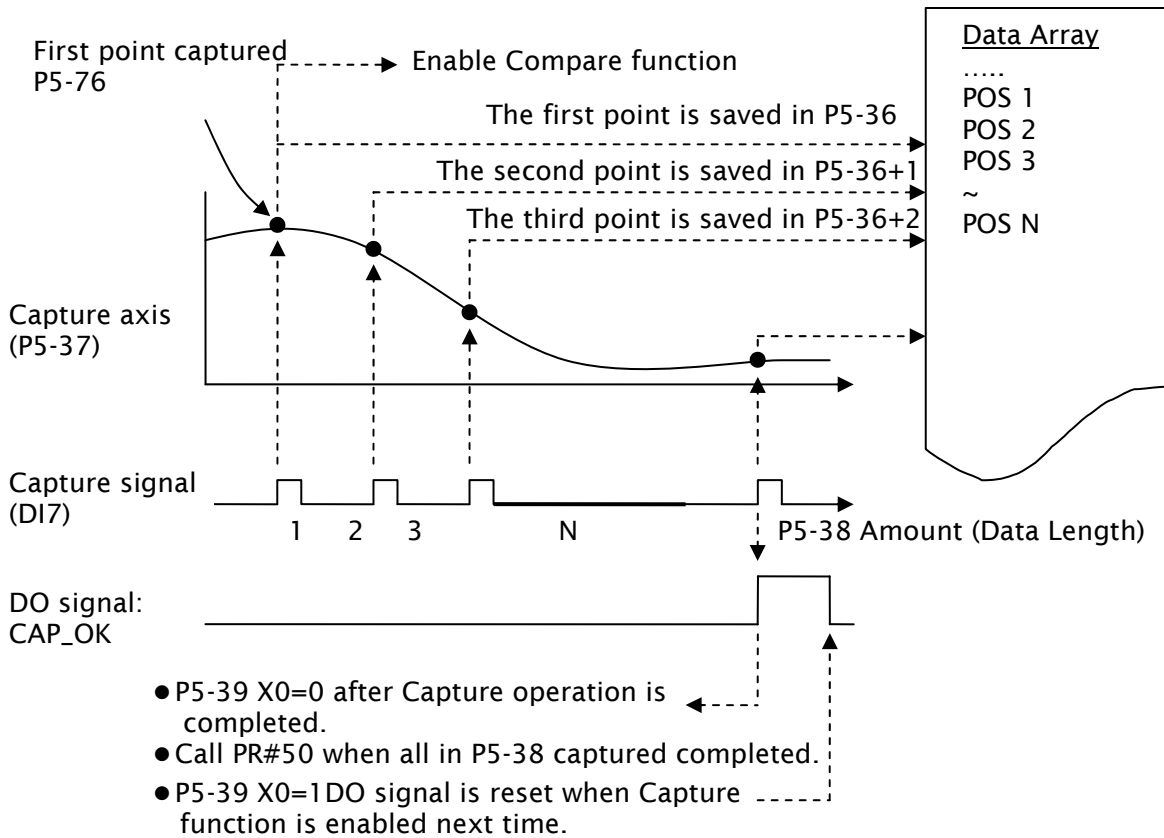
Characteristics of Capture function	
Data Storage Location	<ul style="list-style-type: none"> ● Data array. The starting point is set in P5-36.
Amount	<ul style="list-style-type: none"> ● The amount is determined by P5-38. But, the total amount can not exceed the limit of data array.
Data Format	<ul style="list-style-type: none"> ● 32-bit pulse number (with polarity)
Auxiliary Function	<ul style="list-style-type: none"> ● If Bit 1 of P5-39 X setting is set, P5-37=P5-76 after the first point is captured. ● If Bit 2 of P5-39 X setting is set, the servo system will initiate Compare function automatically after the first point is captured. ● If Bit 3 of P5-39 X setting is set, the servo system will call PR#50 automatically when all data in P5-38 captured completely.
DO Signal: CAP_OK	<ul style="list-style-type: none"> ● The default setting is OFF. ● It will be ON when the last position is captured. ● When Bit0 of P5-39 is set to 1 (P5-39 X0=1), it will be OFF after the capture function is enabled.
Remark	<ul style="list-style-type: none"> ● If P5-38=0 and Bit0 of P5-39 is set to 1 (P5-39 X0=1), Capture function will be disabled. At this time, Bit0 of P5-39 will be reset to 0 (P5-39 X0=0) and the DO signal, CAP_OK will be inactivated (OFF) as well. ● The data format of Capture axis is 32-bit data. Do not calculate the capture data repeatedly; otherwise the overflow may occur and result in error or invalid result.

The data captured by Capture function are all stored in data array. The first captured point is stored in data array (P5-36), the capture amount is determined by P5-38 and the last captured point is stored in data array (P5-36+P5-38-1). When Bit0=1 (P5-39 X setting value), the Capture function is enabled. Once DI7 is triggered every time, one position data will be captured and stored into data array. At this time, the setting value of P5-38 will decrease 1 automatically until the capture amount is reached, i.e. the setting value of P5-38 becomes 0. When capture function has finished, the value of Bit0 (P5-39 X setting value) will be reset to 0 automatically, and DO signal, CAP_OK will be activated.

When the first point is captured, users can choose to reset the position of Capture axis. Then, the value of the first capture point must be the value of P5-76 and the captured value after the second captured point will be the movement relative to the first captured point. This kind of Capture is called "Relative Capture". However, if users choose not to reset the first captured point, the capture method is called "Absolute Capture".

When capturing the first point, users can select to enable Compare function as well

Capture Operation:



7.11.2 Compare Function

The Compare function is a reverse process of the Capture function. The items stored in data array will be compared to the signal of a physical axis (main encoder, linear encoder, or pulse train).

The Compare function uses the instant position of motion axis to compare with the value which store in data array. When the compare conditions are satisfied, DO4 signal will output immediately for motion control.

The signal to DO4 for Compare function is a physical signal and cannot be simulated from software. It can complete precise Compare function for high-speed motion axis.

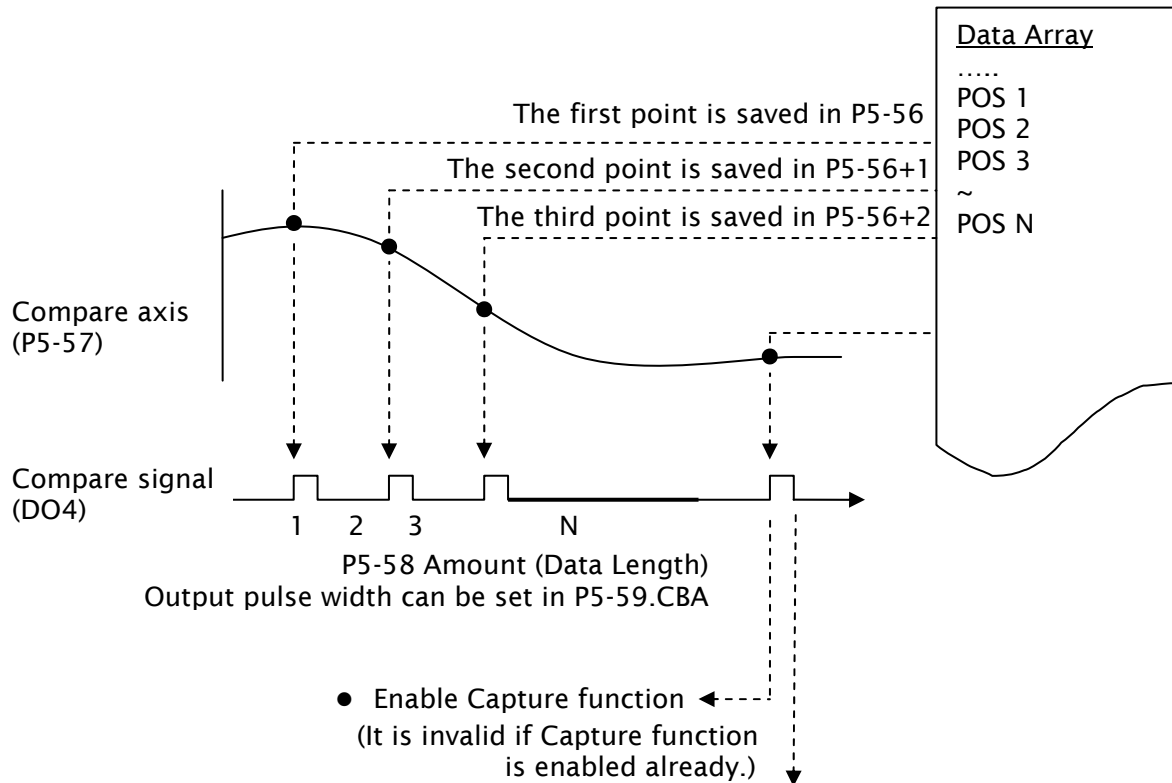
The characteristics of Compare function is described as follows:

Characteristics of Compare function	
Sources	<p>Three sources of Compare function:</p> <ul style="list-style-type: none"> ● Main encoder: Motor encoder ● Auxiliary encoder: Linear scale ● Pulse command: Pulse train ● Capture axis (When the source is the capture axis, the capture source setting can not be changed.) <p>The selected source axis will be displayed by P5-57. Before executing Capture function, please set P5-57 first.</p>

Characteristics of Compare function	
Trigger Signal	<ul style="list-style-type: none"> ● It is output by DO4 and the response time is 1 usec. Please note: DO4 signal is a physical signal used to control Compare function directly. No matter what the setting value of P2-21 is, when DO4 is triggered, Compare function will be enabled always. After Compare function is enabled, in order to avoid the malfunction of the other DO signals, the system will force the other DO signals to be disabled, i.e. set P2-21=0x0100 automatically. Please note that the setting value of P2-21 will not be written into EEPROM when power is off. After re-power the servo drive, the setting value of P2-21 will be restored to its default setting automatically.
Output Method	<ul style="list-style-type: none"> ● Pulse output. A or B contact can be selectable. ● It is able to compare multiple positions continuously. ● The output pulse width can be set also.
Data Storage Location	<ul style="list-style-type: none"> ● Data array. The starting point is set in P5-56.
Amount	<ul style="list-style-type: none"> ● The amount is determined by P5-58. But, the total amount can not exceed the limit of data array.
Data Format	<ul style="list-style-type: none"> ● 32-bit pulse number (with polarity)
Compare Condition	<ul style="list-style-type: none"> ● It is triggered when the position of source axis pass through the compare value.
Auxiliary Function	<ul style="list-style-type: none"> ● Continuous Mode: When the last point is compared, the servo system will return to the first point and start Compare operation again. ● After the last point is compared, the servo system will enable Capture function automatically.
Remark	<ul style="list-style-type: none"> ● If P5-58=0 and Bit0 of P5-59 is set to 1 (P5-59 X0=1), Compare function will be disabled. At this time, Bit0 of P5-59 will be reset to 0 (P5-59 X0=0). ● The data format of Compare axis is 32-bit data. Do not calculate the compare data repeatedly; otherwise the overflow may occur and result in error or invalid result.

The data compared by Compare function are all stored in data array. The first compared point is stored in data array (P5-56), the compare amount is determined by P5-58 and the last compared point is stored in data array (P5-56+P5-58-1). When Bit0=1 (P5-59 X setting value), the Compare function is enabled and start to compare the data of the first point. Every time when one position is compared, the pulse signal will output one time. At this time, the setting value of P5-58 will decrease 1 automatically until the compare amount is reached, i.e. the setting value of P5-58 becomes 0. When compare function has finished, the value of Bit0 (P5-59 X setting value) will be reset to 0 automatically.

When the last point is compared, users can choose to compare from the first point again and again, and it is called "Continuous Mode". Or users can choose to enable Capture function automatically after the last point is compared.

Compare Operation:After the last pulse outputs completely:

- Non-continuous mode: P5-59 X0=0 after Compare operation is completed.
- Continuous mode: The servo system keeps repeating the Compare function, P5-59 X0=1

Chapter 8 Servo Parameters

8.1 Definition

There are following eight groups for drive parameters:

- Group 0: Monitor parameters (example: P0-xx)
- Group 1: Basic parameters (example: P1-xx)
- Group 2: Extension parameters (example: P2-xx)
- Group 3: Communication parameters (example: P3-xx)
- Group 4: Diagnosis parameters (example: P4-xx)
- Group 5: Motion control parameters (example: P5-xx)
- Group 6: PR path definition parameters (example: P6-xx)
- Group 7: PR path definition parameters (example: P7-xx)

Abbreviation of control modes:

- PT : Position control mode (command from external signal)
- PR : Position control mode (command from internal signal)
- S : Speed control mode
- T : Torque control mode

Explanation of symbols (marked after parameter)

- (★) Read-only register, such as P0-00, P0-01, P4-00.
- (▲) Parameter cannot be set when Servo On (when the servo drive is enabled), such as P1-00, P1-46 and P2-33.
- (●) Parameter is effective only after the servo drive is restarted (after switching power off and on), such as P1-01 and P3-00.
- (■) Parameter setting values are not retained when power is off, such as P2-31 and P3-06.

8.2 Parameters Summary

8.2.1 Parameters List by Group

Group 0: P0-xx

Monitor Parameters								
Parameter	Name	Function	Default	Unit	Control Mode			
					PT	PR	S	T
P0-00★	VER	Firmware Version	Factory setting	N/A	<input type="radio"/>	<input type="radio"/>	<input type="radio"/>	<input type="radio"/>
P0-01■	ALE	Drive Fault Code	N/A	N/A	<input type="radio"/>	<input type="radio"/>	<input type="radio"/>	<input type="radio"/>
P0-02	STS	Drive Status (Front Panel Display)	00	N/A	<input type="radio"/>	<input type="radio"/>	<input type="radio"/>	<input type="radio"/>
P0-03	MON	Analog Monitor Output	01	N/A	<input type="radio"/>	<input type="radio"/>	<input type="radio"/>	<input type="radio"/>
P0-04 ~ P0-07	Reserved (Do Not Use)							
P0-08★	TSO	Servo Startup Time	0	Hour	<input type="radio"/>	<input type="radio"/>	<input type="radio"/>	<input type="radio"/>
P0-09★	CM1	Status Monitor 1	N/A	N/A	<input type="radio"/>	<input type="radio"/>	<input type="radio"/>	<input type="radio"/>
P0-10★	CM2	Status Monitor 2	N/A	N/A	<input type="radio"/>	<input type="radio"/>	<input type="radio"/>	<input type="radio"/>
P0-11★	CM3	Status Monitor 3	N/A	N/A	<input type="radio"/>	<input type="radio"/>	<input type="radio"/>	<input type="radio"/>
P0-12★	CM4	Status Monitor 4	N/A	N/A	<input type="radio"/>	<input type="radio"/>	<input type="radio"/>	<input type="radio"/>
P0-13★	CM5	Status Monitor 5	N/A	N/A	<input type="radio"/>	<input type="radio"/>	<input type="radio"/>	<input type="radio"/>
P0-14 ~ P0-16	Reserved (Do Not Use)							
P0-17	CM1A	Status Monitor Selection 1	0	N/A	<input type="radio"/>	<input type="radio"/>	<input type="radio"/>	<input type="radio"/>
P0-18	CM2A	Status Monitor Selection 2	0	N/A	<input type="radio"/>	<input type="radio"/>	<input type="radio"/>	<input type="radio"/>
P0-19	CM3A	Status Monitor Selection 3	0	N/A	<input type="radio"/>	<input type="radio"/>	<input type="radio"/>	<input type="radio"/>
P0-20	CM4A	Status Monitor Selection 4	0	N/A	<input type="radio"/>	<input type="radio"/>	<input type="radio"/>	<input type="radio"/>
P0-21	CM5A	Status Monitor Selection 5	0	N/A	<input type="radio"/>	<input type="radio"/>	<input type="radio"/>	<input type="radio"/>
P0-22 ~ P0-24	Reserved (Do Not Use)							
P0-25	MAP0	Mapping Parameter 1	N/A	N/A	<input type="radio"/>	<input type="radio"/>	<input type="radio"/>	<input type="radio"/>
P0-26	MAP1	Mapping Parameter 2	N/A	N/A	<input type="radio"/>	<input type="radio"/>	<input type="radio"/>	<input type="radio"/>
P0-27	MAP2	Mapping Parameter 3	N/A	N/A	<input type="radio"/>	<input type="radio"/>	<input type="radio"/>	<input type="radio"/>
P0-28	MAP3	Mapping Parameter 4	N/A	N/A	<input type="radio"/>	<input type="radio"/>	<input type="radio"/>	<input type="radio"/>
P0-29	MAP4	Mapping Parameter 5	N/A	N/A	<input type="radio"/>	<input type="radio"/>	<input type="radio"/>	<input type="radio"/>
P0-30	MAP5	Mapping Parameter 6	N/A	N/A	<input type="radio"/>	<input type="radio"/>	<input type="radio"/>	<input type="radio"/>
P0-31	MAP6	Mapping Parameter 7	N/A	N/A	<input type="radio"/>	<input type="radio"/>	<input type="radio"/>	<input type="radio"/>
P0-32	MAP7	Mapping Parameter 8	N/A	N/A	<input type="radio"/>	<input type="radio"/>	<input type="radio"/>	<input type="radio"/>
P0-33 ~ P0-34	Reserved (Do Not Use)							

Monitor Parameters								
Parameter	Name	Function	Default	Unit	Control Mode			
					PT	PR	S	T
P0-35	MAP1A	Block Data Read / Write Register 1 (for P0-25)	0x0	N/A	○	○	○	○
P0-36	MAP2A	Block Data Read / Write Register 2 (for P0-26)	0x0	N/A	○	○	○	○
P0-37	MAP3A	Block Data Read / Write Register 3 (for P0-27)	0x0	N/A	○	○	○	○
P0-38	MAP4A	Block Data Read / Write Register 4 (for P0-28)	0x0	N/A	○	○	○	○
P0-39	MAP5A	Block Data Read / Write Register 5 (for P0-29)	0x0	N/A	○	○	○	○
P0-40	MAP6A	Block Data Read / Write Register 6 (for P0-30)	0x0	N/A	○	○	○	○
P0-41	MAP7A	Block Data Read / Write Register 7 (for P0-31)	0x0	N/A	○	○	○	○
P0-42	MAP8A	Block Data Read / Write Register 8 (for P0-32)	0x0	N/A	○	○	○	○
P0-43	Reserved (Do Not Use)							
P0-44	PCMN	Status Monitor Register (PC Software Setting)	0x0	N/A	○	○	○	○
P0-45	PCMNA	Status Monitor Register Selection (PC Software Setting)	0x0	N/A	○	○	○	○
P0-46★	SVSTS	Servo Output Status Display	0	N/A	○	○	○	○

Explanation of symbols (marked after parameter)

- (★) Read-only register.
- (▲) Parameter cannot be set when Servo On (when the servo drive is enabled).
- (●) Parameter is effective only after the servo drive is restarted (after switching power off and on).
- (■) Parameter setting values are not retained when power is off.

Group 1: P1-xx

Basic Parameters								
Parameter	Name	Function	Default	Unit	Control Mode			
					PT	PR	S	T
P1-00▲	PTT	External Pulse Input Type	0x2	N/A	<input type="radio"/>			
P1-01●	CTL	Control Mode and Output Direction	0	pulse r/min N-m	<input type="radio"/>	<input type="radio"/>	<input type="radio"/>	<input type="radio"/>
P1-02▲	PSTL	Speed and Torque Limit	0	N/A	<input type="radio"/>	<input type="radio"/>	<input type="radio"/>	<input type="radio"/>
P1-03	AOUT	Pulse Output Polarity Setting	0	N/A	<input type="radio"/>	<input type="radio"/>	<input type="radio"/>	<input type="radio"/>
P1-04	MON1	Analog Monitor Output Proportion 1 (CH1)	100	% (full scale)	<input type="radio"/>	<input type="radio"/>	<input type="radio"/>	<input type="radio"/>
P1-05	MON2	Analog Monitor Output Proportion 2 (CH2)	100	% (full scale)	<input type="radio"/>	<input type="radio"/>	<input type="radio"/>	<input type="radio"/>
P1-06	SFLT	Accel / Decel Smooth Constant of Analog Speed Command (Low-pass Filter)	0	Msec			<input type="radio"/>	
P1-07	TFLT	Smooth Constant of Analog Torque Command (Low-pass Filter)	0	Msec				<input type="radio"/>
P1-08	PFLT	Smooth Constant of Position Command (Low-pass Filter)	0	msec	<input type="radio"/>			
P1-09 ~ P1-11	SP1 ~ 3	1st ~ 3rd Speed Command 1st ~ 3rd Speed Limit	-60000 ~ +60000	r/min			<input type="radio"/>	<input type="radio"/>
P1-12 ~ P1-14	TQ1 ~ 3	1st ~ 3rd Torque Command 1st ~ 3rd Torque Limit	-300 ~ +300	%	<input type="radio"/>		<input type="radio"/>	<input type="radio"/>
P1-15 ~ P1-24	Reserved (Do Not Use)							
P1-25	VSF1	Low-frequency Vibration Suppression (1)	100.0	Hz	<input type="radio"/>	<input type="radio"/>		
P1-26	VSG1	Low-frequency Vibration Suppression Gain (1)	0	N/A	<input type="radio"/>	<input type="radio"/>		
P1-27	VSF2	Low-frequency Vibration Suppression (2)	100.0	Hz	<input type="radio"/>	<input type="radio"/>		
P1-28	VSG2	Low-frequency Vibration Suppression Gain (2)	0	N/A	<input type="radio"/>	<input type="radio"/>		
P1-29	AVSM	Auto Low-frequency Vibration Suppression Mode Selection	0	N/A	<input type="radio"/>	<input type="radio"/>		
P1-30	VCL	Low-frequency Vibration Detection Level	500	pulse	<input type="radio"/>	<input type="radio"/>		
P1-31	Reserved (Do Not Use)							
P1-32	LSTP	Motor Stop Mode Selection	0	N/A	<input type="radio"/>	<input type="radio"/>	<input type="radio"/>	<input type="radio"/>
P1-33	Reserved (Do Not Use)							
P1-34	TACC	Acceleration Time	200	msec			<input type="radio"/>	

Basic Parameters								
Parameter	Name	Function	Default	Unit	Control Mode			
					PT	PR	S	T
P1-35	TDEC	Deceleration Time	200	msec			<input type="radio"/>	
P1-36	TSL	Accel /Decel S-curve	0	msec		<input type="radio"/>	<input type="radio"/>	
P1-37	GDR	Ratio of Load Inertia to Servo Motor Inertia	10	0.1 times	<input type="radio"/>	<input type="radio"/>	<input type="radio"/>	<input type="radio"/>
P1-38	ZSPD	Zero Speed Range Setting	100	0.1 r/min	<input type="radio"/>	<input type="radio"/>	<input type="radio"/>	<input type="radio"/>
P1-39	SSPD	Target Motor Speed	3000	r/min	<input type="radio"/>	<input type="radio"/>	<input type="radio"/>	<input type="radio"/>
P1-40▲	VCM	Max. Analog Speed Command or Limit	rated speed	r/min			<input type="radio"/>	<input type="radio"/>
P1-41▲	TCM	Max. Analog Torque Command or Limit	100	%	<input type="radio"/>	<input type="radio"/>	<input type="radio"/>	<input type="radio"/>
P1-42	MBT1	On Delay Time of Electromagnetic Brake	0	msec	<input type="radio"/>	<input type="radio"/>	<input type="radio"/>	<input type="radio"/>
P1-43	MBT2	OFF Delay Time of Electromagnetic Brake	-1000 ~ 1000	msec	<input type="radio"/>	<input type="radio"/>	<input type="radio"/>	<input type="radio"/>
P1-44▲	GR1	Electronic Gear Ratio (1st Numerator) (N1)	128	pulse	<input type="radio"/>	<input type="radio"/>		
P1-45	GR2	Electronic Gear Ratio (Denominator) (M)	10	pulse	<input type="radio"/>	<input type="radio"/>		
P1-46▲	GR3	Encoder Output Pulse Number	2500	pulse	<input type="radio"/>	<input type="radio"/>	<input type="radio"/>	<input type="radio"/>
P1-47	SPOK	Speed Reached Output Range	10	N/A			<input type="radio"/>	
P1-48	MCOK	Motion Control Completed Output Selection	0x0000	N/A	<input type="radio"/>			
P1-49 ~ P1-51	Reserved (Do Not Use)							
P1-52	RES1	Regenerative Resistor Value	-	Ohm	<input type="radio"/>	<input type="radio"/>	<input type="radio"/>	<input type="radio"/>
P1-53	RES2	Regenerative Resistor Capacity	-	Watt	<input type="radio"/>	<input type="radio"/>	<input type="radio"/>	<input type="radio"/>
P1-54	PER	Positioning Completed Width	12800	pulse	<input type="radio"/>	<input type="radio"/>		
P1-55	MSPD	Maximum Speed Limit	rated speed	r/min	<input type="radio"/>	<input type="radio"/>	<input type="radio"/>	<input type="radio"/>
P1-56	OVW	Output Overload Warning Time	120	%	<input type="radio"/>	<input type="radio"/>	<input type="radio"/>	<input type="radio"/>
P1-57	CRSHA	Motor Protection Percentage	0	%	<input type="radio"/>	<input type="radio"/>	<input type="radio"/>	<input type="radio"/>
P1-58	CRSHT	Motor Protection Time	1	msec	<input type="radio"/>	<input type="radio"/>	<input type="radio"/>	<input type="radio"/>
P1-59	MFLT	Analog Speed Linear Filter (Moving Filter)	0	0.1 msec			<input type="radio"/>	
P1-60 ~ P1-61	Reserved (Do Not Use)							
P1-62	FRCL	Friction Compensation Percentage	0	%	<input type="radio"/>	<input type="radio"/>	<input type="radio"/>	
P1-63	FRCT	Friction Compensation Smooth Constant	0	msec	<input type="radio"/>	<input type="radio"/>	<input type="radio"/>	

Basic Parameters								
Parameter	Name	Function	Default	Unit	Control Mode			
					PT	PR	S	T
P1-64 ~ P1-65	Reserved (Do Not Use)							
P1-66	PCM	Max. Rotation Number of Analog Position Command (will be available soon)	30	0.1 rotation	<input type="radio"/>			
P1-67	Reserved (Do Not Use)							
P1-68	PFLT2	Position Command Moving Filter	4	msec	<input type="radio"/>	<input type="radio"/>		
P1-69 ~ P1-71	Reserved (Do Not Use)							
P1-72	FRES	Full-closed Loop Resolution	5000	pulse/rev	<input type="radio"/>	<input type="radio"/>		
P1-73	FERR	Full-closed Loop Excessive Position Error Range	30000	pulse	<input type="radio"/>	<input type="radio"/>		
P1-74▲	FCON	Full-closed Loop Control Function Selection	000h	N/A	<input type="radio"/>	<input type="radio"/>		
P1-75	FELP	Full-closed Loop Low-pass Filter Time Constant	100	msec	<input type="radio"/>	<input type="radio"/>		
P1-76	AMSPD	Max. Rotation Speed of Encoder Output	5500	r/min	<input type="radio"/>	<input type="radio"/>	<input type="radio"/>	<input type="radio"/>

Explanation of symbols (marked after parameter)

- (★) Read-only register.
- (▲) Parameter cannot be set when Servo On (when the servo drive is enabled).
- (●) Parameter is effective only after the servo drive is restarted (after switching power off and on).
- (■) Parameter setting values are not retained when power is off.

Group 2: P2-xx

Extension Parameters								
Parameter	Name	Function	Default	Unit	Control Mode			
					PT	PR	S	T
P2-00	KPP	Proportional Position Loop Gain	35	rad/s	<input type="radio"/>	<input type="radio"/>	<input type="radio"/>	<input type="radio"/>
P2-01	PPR	Position Loop Gain Switching Rate	100	%	<input type="radio"/>	<input type="radio"/>	<input type="radio"/>	<input type="radio"/>
P2-02	PFG	Position Feed Forward Gain	50	%	<input type="radio"/>	<input type="radio"/>	<input type="radio"/>	<input type="radio"/>
P2-03	PFF	Smooth Constant of Position Feed Forward Gain	5	msec	<input type="radio"/>	<input type="radio"/>	<input type="radio"/>	<input type="radio"/>
P2-04	KVP	Proportional Speed Loop Gain	500	rad/s	<input type="radio"/>	<input type="radio"/>	<input type="radio"/>	<input type="radio"/>
P2-05	SPR	Speed Loop Gain Switching Rate	100	%	<input type="radio"/>	<input type="radio"/>	<input type="radio"/>	<input type="radio"/>
P2-06	KVI	Speed Integral Compensation	100	rad/s	<input type="radio"/>	<input type="radio"/>	<input type="radio"/>	<input type="radio"/>
P2-07	KVF	Speed Feed Forward Gain	0	%	<input type="radio"/>	<input type="radio"/>	<input type="radio"/>	<input type="radio"/>
P2-08■	PCTL	Special Factory Setting	0	N/A	<input type="radio"/>	<input type="radio"/>	<input type="radio"/>	<input type="radio"/>
P2-09	DRT	Bounce Filter	2	2ms	<input type="radio"/>	<input type="radio"/>	<input type="radio"/>	<input type="radio"/>
P2-10	DI1	Digital Input Terminal 1 (DI1)	101	N/A	<input type="radio"/>	<input type="radio"/>	<input type="radio"/>	<input type="radio"/>
P2-11	DI2	Digital Input Terminal 2 (DI2)	104	N/A	<input type="radio"/>	<input type="radio"/>	<input type="radio"/>	<input type="radio"/>
P2-12	DI3	Digital Input Terminal 3 (DI3)	116	N/A	<input type="radio"/>	<input type="radio"/>	<input type="radio"/>	<input type="radio"/>
P2-13	DI4	Digital Input Terminal 4 (DI4)	117	N/A	<input type="radio"/>	<input type="radio"/>	<input type="radio"/>	<input type="radio"/>
P2-14	DI5	Digital Input Terminal 5 (DI5)	102	N/A	<input type="radio"/>	<input type="radio"/>	<input type="radio"/>	<input type="radio"/>
P2-15	DI6	Digital Input Terminal 6 (DI6)	22	N/A	<input type="radio"/>	<input type="radio"/>	<input type="radio"/>	<input type="radio"/>
P2-16	DI7	Digital Input Terminal 7 (DI7)	23	N/A	<input type="radio"/>	<input type="radio"/>	<input type="radio"/>	<input type="radio"/>
P2-17	DI8	Digital Input Terminal 8 (DI8)	21	N/A	<input type="radio"/>	<input type="radio"/>	<input type="radio"/>	<input type="radio"/>
P2-18	DO1	Digital Output Terminal 1 (DO1)	101	N/A	<input type="radio"/>	<input type="radio"/>	<input type="radio"/>	<input type="radio"/>
P2-19	DO2	Digital Output Terminal 2 (DO2)	103	N/A	<input type="radio"/>	<input type="radio"/>	<input type="radio"/>	<input type="radio"/>
P2-20	DO3	Digital Output Terminal 3 (DO3)	109	N/A	<input type="radio"/>	<input type="radio"/>	<input type="radio"/>	<input type="radio"/>
P2-21	DO4	Digital Output Terminal 4 (DO4)	105	N/A	<input type="radio"/>	<input type="radio"/>	<input type="radio"/>	<input type="radio"/>
P2-22	DO5	Digital Output Terminal 5 (DO5)	7	N/A	<input type="radio"/>	<input type="radio"/>	<input type="radio"/>	<input type="radio"/>
P2-23	NCF	Notch Filter 1 (Resonance Suppression)	1000	Hz	<input type="radio"/>	<input type="radio"/>	<input type="radio"/>	<input type="radio"/>
P2-24	DPH	Notch Filter Attenuation Rate 1 (Resonance Suppression)	0	dB	<input type="radio"/>	<input type="radio"/>	<input type="radio"/>	<input type="radio"/>
P2-25	NLP	Low-pass Filter Time Constant (Resonance Suppression)	2 or 5	0.1ms	<input type="radio"/>	<input type="radio"/>	<input type="radio"/>	<input type="radio"/>
P2-26	DST	External Anti-Interference Gain	0	0.001	<input type="radio"/>	<input type="radio"/>	<input type="radio"/>	<input type="radio"/>
P2-27	GCC	Gain Switching Control Selection	0	N/A	<input type="radio"/>	<input type="radio"/>	<input type="radio"/>	<input type="radio"/>
P2-28	GUT	Gain Switching Time Constant	10	10msec	<input type="radio"/>	<input type="radio"/>	<input type="radio"/>	<input type="radio"/>

Chapter 8 Servo Parameters

ASDA-A2

Extension Parameters								
Parameter	Name	Function	Default	Unit	Control Mode			
					PT	PR	S	T
P2-29	GPE	Gain Switching Condition	1280000	pulse Kpps r/min	<input type="checkbox"/>	<input type="checkbox"/>	<input type="checkbox"/>	<input type="checkbox"/>
P2-30■	INH	Auxiliary Function	0	N/A	<input type="checkbox"/>	<input type="checkbox"/>	<input type="checkbox"/>	<input type="checkbox"/>
P2-31	AUT1	Speed Frequency Response Level in Auto and Semi-Auto Mode	80	Hz	<input type="checkbox"/>	<input type="checkbox"/>	<input type="checkbox"/>	<input type="checkbox"/>
P2-32▲	AUT2	Tuning Mode Selection	0	N/A	<input type="checkbox"/>	<input type="checkbox"/>	<input type="checkbox"/>	<input type="checkbox"/>
P2-33▲	INF	Semi-Auto Mode Inertia Adjustment Selection	0	N/A	<input type="checkbox"/>	<input type="checkbox"/>	<input type="checkbox"/>	<input type="checkbox"/>
P2-34	SDEV	Overspeed Warning Condition	5000	r/min			<input type="checkbox"/>	
P2-35	PDEV	Excessive Error Warning Condition	3840000	pulse	<input type="checkbox"/>	<input type="checkbox"/>		
P2-36	EDI9	External Digital Input Terminal 9 (EDI9)	0	N/A	<input type="checkbox"/>	<input type="checkbox"/>	<input type="checkbox"/>	<input type="checkbox"/>
P2-37	EDI10	External Digital Input Terminal 10 (EDI10)	0	N/A	<input type="checkbox"/>	<input type="checkbox"/>	<input type="checkbox"/>	<input type="checkbox"/>
P2-38	EDI11	External Digital Input Terminal 11 (EDI11)	0	N/A	<input type="checkbox"/>	<input type="checkbox"/>	<input type="checkbox"/>	<input type="checkbox"/>
P2-39	EDI12	External Digital Input Terminal 12 (EDI12)	0	N/A	<input type="checkbox"/>	<input type="checkbox"/>	<input type="checkbox"/>	<input type="checkbox"/>
P2-40	EDI13	External Digital Input Terminal 13 (EDI13)	0	N/A	<input type="checkbox"/>	<input type="checkbox"/>	<input type="checkbox"/>	<input type="checkbox"/>
P2-41	EDI14	External Digital Input Terminal 14 (EDI14)	0	N/A	<input type="checkbox"/>	<input type="checkbox"/>	<input type="checkbox"/>	<input type="checkbox"/>
P2-42	Reserved (Do Not Use)							
P2-43	NCF2	Notch Filter 2 (Resonance Suppression)	1000	Hz	<input type="checkbox"/>	<input type="checkbox"/>	<input type="checkbox"/>	<input type="checkbox"/>
P2-44	DPH2	Notch Filter Attenuation Rate 2 (Resonance Suppression)	0	dB	<input type="checkbox"/>	<input type="checkbox"/>	<input type="checkbox"/>	<input type="checkbox"/>
P2-45	DOD	Notch Filter 3 (Resonance Suppression)	1000	Hz	<input type="checkbox"/>	<input type="checkbox"/>	<input type="checkbox"/>	<input type="checkbox"/>
P2-46	FSN	Notch Filter Attenuation Rate 3 (Resonance Suppression)	0	dB	<input type="checkbox"/>	<input type="checkbox"/>	<input type="checkbox"/>	<input type="checkbox"/>
P2-47	PED	Auto Resonance Suppression Mode Selection	1	N/A	<input type="checkbox"/>	<input type="checkbox"/>	<input type="checkbox"/>	<input type="checkbox"/>
P2-48	BLAS	Auto Resonance Suppression Detection Level	100	N/A	<input type="checkbox"/>	<input type="checkbox"/>	<input type="checkbox"/>	<input type="checkbox"/>
P2-49	SJIT	Speed Detection Filter and Jitter Suppression	0	sec	<input type="checkbox"/>	<input type="checkbox"/>	<input type="checkbox"/>	<input type="checkbox"/>
P2-50	DCLR	Pulse Deviation Clear Mode	0	N/A	<input type="checkbox"/>	<input type="checkbox"/>		
P2-51 ~ P2-52	Reserved (Do Not Use)							

Extension Parameters								
Parameter	Name	Function	Default	Unit	Control Mode			
					PT	PR	S	T
P2-53	KPI	Position Integral Compensation	0	rad/s	<input type="radio"/>	<input type="radio"/>	<input type="radio"/>	<input type="radio"/>
P2-54 ~ P2-59	Reserved (Do Not Use)							
P2-60	GR4	Electronic Gear Ratio (2nd Numerator) (N2)	128	pulse	<input type="radio"/>			
P2-61	GR5	Electronic Gear Ratio (3rd Numerator) (N3)	128	pulse	<input type="radio"/>			
P2-62	GR6	Electronic Gear Ratio (4th Numerator) (N4)	128	pulse	<input type="radio"/>			
P2-63 ~ P2-64	Reserved (Do Not Use)							
P2-65	GBIT	Special Function 1	0	N/A	<input type="radio"/>	<input type="radio"/>	<input type="radio"/>	
P2-66	GBIT2	Special Function 2	0	N/A	<input type="radio"/>	<input type="radio"/>	<input type="radio"/>	
P2-67	JSL	Stable Inertia Estimating Time	1.5	0.1 times	<input type="radio"/>	<input type="radio"/>	<input type="radio"/>	<input type="radio"/>

Explanation of symbols (marked after parameter)

- (★) Read-only register.
- (▲) Parameter cannot be set when Servo On (when the servo drive is enabled).
- (●) Parameter is effective only after the servo drive is restarted (after switching power off and on).
- (■) Parameter setting values are not retained when power is off.

Group 3: P3-xx

Communication Parameters								
Parameter	Name	Function	Default	Unit	Control Mode			
					PT	PR	S	T
P3-00●	ADR	Communication Address Setting	0x7F	N/A	<input type="radio"/>	<input type="radio"/>	<input type="radio"/>	<input type="radio"/>
P3-01	BRT	Transmission Speed	0x0203	bps	<input type="radio"/>	<input type="radio"/>	<input type="radio"/>	<input type="radio"/>
P3-02	PTL	Communication Protocol	6	N/A	<input type="radio"/>	<input type="radio"/>	<input type="radio"/>	<input type="radio"/>
P3-03	FLT	Transmission Fault Treatment	0	N/A	<input type="radio"/>	<input type="radio"/>	<input type="radio"/>	<input type="radio"/>
P3-04	CWD	Communication Time Out Detection	0	sec	<input type="radio"/>	<input type="radio"/>	<input type="radio"/>	<input type="radio"/>
P3-05	CMM	Communication Selection	0	N/A	<input type="radio"/>	<input type="radio"/>	<input type="radio"/>	<input type="radio"/>
P3-06■	SDI	Digital Input Communication Function	0	N/A	<input type="radio"/>	<input type="radio"/>	<input type="radio"/>	<input type="radio"/>
P3-07	CDT	Communication Response Delay Time	0	1 ms	<input type="radio"/>	<input type="radio"/>	<input type="radio"/>	<input type="radio"/>
P3-08■	MNS	Monitor Mode	0000	N/A	<input type="radio"/>	<input type="radio"/>	<input type="radio"/>	<input type="radio"/>
P3-09	SYC	CANopen Synchronization Setting	0x57A1	N/A	CANopen mode			
P3-10 ~ P3-11	Reserved (Do Not Use)							

Explanation of symbols (marked after parameter)

- (★) Read-only register.
- (▲) Parameter cannot be set when Servo On (when the servo drive is enabled).
- (●) Parameter is effective only after the servo drive is restarted (after switching power off and on).
- (■) Parameter setting values are not retained when power is off.

Group 4: P4-xx

Diagnosis Parameters								
Parameter	Name	Function	Default	Unit	Control Mode			
					PT	PR	S	T
P4-00★	ASH1	Fault Record (N)	0	N/A	<input type="radio"/>	<input type="radio"/>	<input type="radio"/>	<input type="radio"/>
P4-01★	ASH2	Fault Record (N-1)	0	N/A	<input type="radio"/>	<input type="radio"/>	<input type="radio"/>	<input type="radio"/>
P4-02★	ASH3	Fault Record (N-2)	0	N/A	<input type="radio"/>	<input type="radio"/>	<input type="radio"/>	<input type="radio"/>
P4-03★	ASH4	Fault Record (N-3)	0	N/A	<input type="radio"/>	<input type="radio"/>	<input type="radio"/>	<input type="radio"/>
P4-04★	ASH5	Fault Record (N-4)	0	N/A	<input type="radio"/>	<input type="radio"/>	<input type="radio"/>	<input type="radio"/>
P4-05	JOG	JOG Operation	20	r/min	<input type="radio"/>	<input type="radio"/>	<input type="radio"/>	<input type="radio"/>
P4-06▲■	FOT	Force Output Contact Control	0	N/A	<input type="radio"/>	<input type="radio"/>	<input type="radio"/>	<input type="radio"/>
P4-07■	ITST	Input Status	0	N/A	<input type="radio"/>	<input type="radio"/>	<input type="radio"/>	<input type="radio"/>
P4-08★	PKEY	Digital Keypad Input of Servo Drive	N/A	N/A	<input type="radio"/>	<input type="radio"/>	<input type="radio"/>	<input type="radio"/>
P4-09★	MOT	Output Status	N/A	N/A	<input type="radio"/>	<input type="radio"/>	<input type="radio"/>	<input type="radio"/>
P4-10■	CEN	Adjustment Function	0	N/A	<input type="radio"/>	<input type="radio"/>	<input type="radio"/>	<input type="radio"/>
P4-11	SOF1	Analog Speed Input Drift Adjustment 1	Factory setting	N/A	<input type="radio"/>	<input type="radio"/>	<input type="radio"/>	<input type="radio"/>
P4-12	SOF2	Analog Speed Input Drift Adjustment 2	Factory setting	N/A	<input type="radio"/>	<input type="radio"/>	<input type="radio"/>	<input type="radio"/>
P4-13	TOF1	Analog Torque Drift Adjustment 1	Factory setting	N/A	<input type="radio"/>	<input type="radio"/>	<input type="radio"/>	<input type="radio"/>
P4-14	TOF2	Analog Torque Drift Adjustment 2	Factory setting	N/A	<input type="radio"/>	<input type="radio"/>	<input type="radio"/>	<input type="radio"/>
P4-15	COF1	Current Detector Drift Adjustment (V1 phase)	Factory setting	N/A	<input type="radio"/>	<input type="radio"/>	<input type="radio"/>	<input type="radio"/>
P4-16	COF2	Current Detector Drift Adjustment (V2 phase)	Factory setting	N/A	<input type="radio"/>	<input type="radio"/>	<input type="radio"/>	<input type="radio"/>
P4-17	COF3	Current Detector Drift Adjustment (W1 phase)	Factory setting	N/A	<input type="radio"/>	<input type="radio"/>	<input type="radio"/>	<input type="radio"/>
P4-18	COF4	Current Detector Drift Adjustment (W2 phase)	Factory setting	N/A	<input type="radio"/>	<input type="radio"/>	<input type="radio"/>	<input type="radio"/>
P4-19	TIGB	IGBT NTC Calibration	Factory setting	N/A	<input type="radio"/>	<input type="radio"/>	<input type="radio"/>	<input type="radio"/>
P4-20	DOF1	Analog Monitor Output Drift Adjustment (CH1)	0	mV	<input type="radio"/>	<input type="radio"/>	<input type="radio"/>	<input type="radio"/>
P4-21	DOF2	Analog Monitor Output Drift Adjustment (CH2)	0	mV	<input type="radio"/>	<input type="radio"/>	<input type="radio"/>	<input type="radio"/>
P4-22	SAO	Analog Speed Input Offset	0	mV			<input type="radio"/>	
P4-23	TAO	Analog Torque Input Offset	0	mV				<input type="radio"/>
P4-24	LVL	Undervoltage Error Level	160	V(rms)	<input type="radio"/>	<input type="radio"/>	<input type="radio"/>	<input type="radio"/>

Group 5: P5-xx

Motion Control Parameters								
Parameter	Name	Function	Default	Unit	Control Mode			
					PT	PR	S	T
P5-00 ~ P5-02	Reserved (Do Not Use)							
P5-03	PDEC	Deceleration Time of Protectin Function	0XE0EFEEFF	N/A	<input type="checkbox"/>	<input type="checkbox"/>	<input type="checkbox"/>	<input type="checkbox"/>
P5-04	HMOV	Homing Mode	0	N/A	<input type="checkbox"/>	<input type="checkbox"/>	<input type="checkbox"/>	<input type="checkbox"/>
P5-05	HSPD1	1st Speed Setting of High Speed Homing	100.0	0.1 r/min	<input type="checkbox"/>	<input type="checkbox"/>	<input type="checkbox"/>	<input type="checkbox"/>
P5-06	HSPD2	2nd Speed Setting of Low Speed Homing	20.0	0.1 r/min	<input type="checkbox"/>	<input type="checkbox"/>	<input type="checkbox"/>	<input type="checkbox"/>
P5-07■	PRCM	Trigger Position Command (PR mode only)	0	N/A	<input type="checkbox"/>	<input type="checkbox"/>	<input type="checkbox"/>	<input type="checkbox"/>
P5-08	SWLP	Forward Software Limit	2147483647	PUU	<input type="checkbox"/>	<input type="checkbox"/>	<input type="checkbox"/>	<input type="checkbox"/>
P5-09	SWLN	Reverse Software Limit	-2147483648	PUU	<input type="checkbox"/>	<input type="checkbox"/>	<input type="checkbox"/>	<input type="checkbox"/>
P5-10★	AYSZ	Data Array: Data Amount (N x 32 bits)	N/A	N/A	<input type="checkbox"/>	<input type="checkbox"/>	<input type="checkbox"/>	<input type="checkbox"/>
P5-11■	AYID	Data Array: Read / Write Address	0	N/A	<input type="checkbox"/>	<input type="checkbox"/>	<input type="checkbox"/>	<input type="checkbox"/>
P5-12■	AYD0	Data Array: Read / Write Data Block 1	0	N/A	<input type="checkbox"/>	<input type="checkbox"/>	<input type="checkbox"/>	<input type="checkbox"/>
P5-13■	AYD1	Data Array: Read / Write Data Block 2	0	N/A	<input type="checkbox"/>	<input type="checkbox"/>	<input type="checkbox"/>	<input type="checkbox"/>
P5-14	Reserved (Do Not Use)							
P5-15■	PMEM	PATH 1 ~ PATH 2 Data Not Retained Setting	0x0	N/A	<input type="checkbox"/>	<input type="checkbox"/>	<input type="checkbox"/>	<input type="checkbox"/>
P5-16■	AXEN	Axis Position: Motor Encoder	0	PUU	<input type="checkbox"/>	<input type="checkbox"/>	<input type="checkbox"/>	<input type="checkbox"/>
P5-17	AXAU	Axis Position: Auxiliary Encoder (Pulse Command Feedback)	N/A	pulse	<input type="checkbox"/>	<input type="checkbox"/>	<input type="checkbox"/>	<input type="checkbox"/>
P5-18	AXPC	Axis Position: Pulse Command	N/A	pulse	<input type="checkbox"/>	<input type="checkbox"/>	<input type="checkbox"/>	<input type="checkbox"/>
P5-19	TBS	E-Cam Curve Scaling	1.000000	1/(10 ⁶)	<input type="checkbox"/>	<input type="checkbox"/>	<input type="checkbox"/>	<input type="checkbox"/>
P5-20 ~ P5-33	AC0 ~ AC13	Accel / Decel Time 0 ~ 13	200 ~ 8000	msec	<input type="checkbox"/>	<input type="checkbox"/>	<input type="checkbox"/>	<input type="checkbox"/>
P5-34	AC14	Accel / Decel Time 14	50	msec	<input type="checkbox"/>	<input type="checkbox"/>	<input type="checkbox"/>	<input type="checkbox"/>
P5-35	AC15	Accel / Decel Time 15	30	msec	<input type="checkbox"/>	<input type="checkbox"/>	<input type="checkbox"/>	<input type="checkbox"/>
P5-36	CAST	CAPTURE: Start Address of Data Array	0	N/A	<input type="checkbox"/>	<input type="checkbox"/>	<input type="checkbox"/>	<input type="checkbox"/>
P5-37■	CAAX	CAPTURE: Axis Position CNT	0	N/A	<input type="checkbox"/>	<input type="checkbox"/>	<input type="checkbox"/>	<input type="checkbox"/>
P5-38■	CANO	CAPTURE: Capture Amount	1	N/A	<input type="checkbox"/>	<input type="checkbox"/>	<input type="checkbox"/>	<input type="checkbox"/>
P5-39■	CACT	CAPTURE: Capture Source Setting	0x2010	N/A	<input type="checkbox"/>	<input type="checkbox"/>	<input type="checkbox"/>	<input type="checkbox"/>

Motion Control Parameters								
Parameter	Name	Function	Default	Unit	Control Mode			
					PT	PR	S	T
P5-40 ~ P5-55	DLY0 ~ DLY15	Delay Time 0 ~ 15	0 ~ 5500	msec		○		
P5-56	CMST	COMPARE: Start Address of Data Array	0	N/A	○	○	○	○
P5-57■	CMAx	COMPARE: Axis Position	0	N/A	○	○	○	○
P5-58■	CMNO	COMPARE: Compare Amount	1	N/A	○	○	○	○
P5-59	CMCT	COMPARE: Compare Source Setting	00640010h	N/A	○	○	○	○
P5-60 ~ P5-75	POV0 ~ POV15	Moving Speed Setting of Position 0 ~ 15	20.0 ~ 3000.0	0.1 r/min		○		
P5-76★	CPRS	Capture 1st Position Reset Data	0	N/A	○	○	○	○
P5-77■	CSAX	Position of CAPTURE SYNC AXIS	0	N/A	○	○	○	○
P5-78	CSDS	Interval Pulse Number of CAPTURE SYNC AXIS	100	pulse	○	○	○	○
P5-79■	CSDS	Error Pulse Number of CAPTURE SYNC AXIS	0	pulse	○	○	○	○
P5-80	CSDS	Max. Correction Rate of CAPTURE SYNC AXIS	10	%	○	○	○	○
P5-81	ECHD	E-Cam: Start Address of Data Array	100	N/A	○	○	○	○
P5-82	ECMN	E-Cam: E-Cam Area Number N (at least >=5)	5	N/A		○		
P5-83	ECMM	E-Cam: E-Cam Cycle Number (M)	1	N/A		○		
P5-84	ECMP	E-Cam: Pulse Number of Master Axis (P)	3600	N/A		○		
P5-85	ECME	E-Cam: Engage Area Number	0	N/A		○		
P5-86■	ECAX	E-Cam: Position of Master Axis	0	N/A		○		
P5-87	PLED	E-Cam: Lead Command Length	0	N/A		○		
P5-88■	ECON	E-Cam: E-Cam Setting	00000000h	N/A		○		
P5-89	ECRD	E-Cam: Disengage Timing Data	0	N/A		○		
P5-90	CMAp	E-Cam: Area Number + (Polarity is Positive)	0	N/A		○		
P5-91	CMAN	E-Cam: Area Number - (Polarity is Negative)	0	N/A		○		
P5-92	PLED	E-Cam: Cyclic Lead Command Length	0	N/A		○		
P5-93	CSDS	Motion Control: Macro Parameter 4	0	N/A		○		
P5-94	CSDS	Motion Control: Macro Parameter 3	0	N/A		○		

Motion Control Parameters								
Parameter	Name	Function	Default	Unit	Control Mode			
					PT	PR	S	T
P5-95	CSDS	Motion Control: Macro Parameter 2	0	N/A		<input type="radio"/>		
P5-96	CSDS	Motion Control: Macro Parameter 1	0	N/A		<input type="radio"/>		
P5-97■	CSDS	Motion Control: Macro Command	100	pulse	<input type="radio"/>	<input type="radio"/>	<input type="radio"/>	<input type="radio"/>
P5-98	EVON	Event Rising-edge Trigger Command (OFF → ON)	0	N/A		<input type="radio"/>		
P5-99	EVOF	Event Falling-edge Trigger Command (ON → OFF)	0	N/A		<input type="radio"/>		

Explanation of symbols (marked after parameter)

- (★) Read-only register.
- (▲) Parameter cannot be set when Servo On (when the servo drive is enabled).
- (●) Parameter is effective only after the servo drive is restarted (after switching power off and on).
- (■) Parameter setting values are not retained when power is off.

Group 6: P6-xx

PR Path Definition Parameters								
Parameter	Name	Function	Default	Unit	Control Mode			
					PT	PR	S	T
P6-00	PDEC	Homing Definition	0x00000000	N/A		○		
P6-01	ODAT	Homing Definition Value	0	N/A		○		
P6-02 ~ P6-98	PDEF1 ~ PDEF49	Definition of Path 1 ~ 49	0x00000000	N/A		○		
P6-03 ~ P6-99	PDAT1 ~ PDEF49	Data of Path 1 ~ 49	0	N/A		○		

Explanation of symbols (marked after parameter)

- (★) Read-only register.
- (▲) Parameter cannot be set when Servo On (when the servo drive is enabled).
- (●) Parameter is effective only after the servo drive is restarted (after switching power off and on).
- (■) Parameter setting values are not retained when power is off.

Group 7: P7-xx

PR Path Definition Parameters								
Parameter	Name	Function	Default	Unit	Control Mode			
					PT	PR	S	T
P7-00 ~ P7-26	PDEF50 ~ PDEF63	Definition of Path 50 ~ 63	0x00000000	N/A		○		
P7-01 ~ P7-27	PDAT50 ~ PDEF63	Data of Path 50 ~ 49	0	N/A		○		

Explanation of symbols (marked after parameter)

- (★) Read-only register.
- (▲) Parameter cannot be set when Servo On (when the servo drive is enabled).
- (●) Parameter is effective only after the servo drive is restarted (after switching power off and on).
- (■) Parameter setting values are not retained when power is off.

8.2.2 Parameters List by Function

Monitor and General Use									
Parameter	Name	Function	Default	Unit	Control Mode				Related Section
					PT	PR	S	T	
P0-00★	VER	Firmware Version	Factory Setting	N/A	O	O	O	O	-
P0-01■	ALE	Drive Fault Code	N/A	N/A	O	O	O	O	11.1 11.2 11.3
P0-02	STS	Drive Status (Front Panel Display)	00	N/A	O	O	O	O	7.2
P0-03	MON	Analog Monitor Output	01	N/A	O	O	O	O	4.3.5
P0-08★	TSON	Servo Startup Time	0	Hour					-
P0-09★	CM1	Status Monitor 1	N/A	N/A	O	O	O	O	4.3.5
P0-10★	CM2	Status Monitor 2	N/A	N/A	O	O	O	O	4.3.5
P0-11★	CM3	Status Monitor 3	N/A	N/A	O	O	O	O	4.3.5
P0-12★	CM4	Status Monitor 4	N/A	N/A	O	O	O	O	4.3.5
P0-13★	CM5	Status Monitor 5	N/A	N/A	O	O	O	O	4.3.5
P0-17	CM1A	Status Monitor Selection 1	0	N/A					-
P0-18	CM2A	Status Monitor Selection 2	0	N/A					-
P0-19	CM3A	Status Monitor Selection 3	0	N/A					-
P0-20	CM4A	Status Monitor Selection 4	0	N/A					-
P0-21	CM5A	Status Monitor Selection 5	0	N/A					-
P0-25	MAP1	Mapping Parameter 1	N/A	N/A	O	O	O	O	4.3.5
P0-26	MAP2	Mapping Parameter 2	N/A	N/A	O	O	O	O	4.3.5
P0-27	MAP3	Mapping Parameter 3	N/A	N/A	O	O	O	O	4.3.5
P0-28	MAP4	Mapping Parameter 4	N/A	N/A	O	O	O	O	4.3.5
P0-29	MAP5	Mapping Parameter 5	N/A	N/A	O	O	O	O	4.3.5
P0-30	MAP6	Mapping Parameter 6	N/A	N/A	O	O	O	O	4.3.5
P0-31	MAP7	Mapping Parameter 7	N/A	N/A	O	O	O	O	4.3.5
P0-32	MAP8	Mapping Parameter 8	N/A	N/A	O	O	O	O	4.3.5
P0-35	MAP1A	Block Data Read / Write Register 1 (for P0-25)	0x0	N/A	O	O	O	O	4.3.5
P0-36	MAP2A	Block Data Read / Write Register 2 (for P0-26)	0x0	N/A	O	O	O	O	4.3.5
P0-37	MAP3A	Block Data Read / Write Register 3 (for P0-27)	0x0	N/A	O	O	O	O	4.3.5
P0-38	MAP4A	Block Data Read / Write Register 4 (for P0-28)	0x0	N/A	O	O	O	O	4.3.5

Monitor and General Use									
Parameter	Name	Function	Default	Unit	Control Mode				Related Section
					PT	PR	S	T	
P0-39	MAP5A	Block Data Read / Write Register 5 (for P0-29)	0x0	N/A	O	O	O	O	4.3.5
P0-40	MAP6A	Block Data Read / Write Register 6 (for P0-30)	0x0	N/A	O	O	O	O	4.3.5
P0-41	MAP7A	Block Data Read / Write Register 7 (for P0-31)	0x0	N/A	O	O	O	O	4.3.5
P0-42	MAP8A	Block Data Read / Write Register 8 (for P0-32)	0x0	N/A	O	O	O	O	4.3.5
P0-46★	SVSTS	Servo Output Status Display	0	N/A	O	O	O	O	-
P1-04	MON1	Analog Monitor Output Proportion 1 (CH1)	100	% (full scale)	O	O	O	O	6.4.4
P1-05	MON2	Analog Monitor Output Proportion 2 (CH2)	100	% (full scale)	O	O	O	O	6.4.4

Explanation of symbols (marked after parameter)

- (★) Read-only register.
- (▲) Parameter cannot be set when Servo On (when the servo drive is enabled).
- (●) Parameter is effective only after the servo drive is restarted (after switching power off and on).
- (■) Parameter setting values are not retained when power is off.

Smooth Filter and Resonance Suppression									
Parameter	Name	Function	Default	Unit	Control Mode				Related Section
					PT	PR	S	T	
P1-06	SFLT	Accel / Decel Smooth Constant of Analog Speed Command (Low-pass Filter)	0	msec			O		6.3.3
P1-07	TFLT	Smooth Constant of Analog Torque Command (Low-pass Filter)	0	msec				O	6.4.3
P1-08	PFLT	Smooth Constant of Position Command (Low-pass Filter)	0	10 msec	O	O			6.2.6
P1-25	VSF1	Low-frequency Vibration Suppression (1)	100.0	0.1Hz	O	O			6.2.9
P1-26	VSG1	Low-frequency Vibration Suppression Gain (1)	0	N/A	O	O			6.2.9
P1-27	VSF2	Low-frequency Vibration Suppression (2)	100.0	0.1Hz	O	O			6.2.9
P1-28	VSG2	Low-frequency Vibration Suppression Gain (2)	0	N/A	O	O			6.2.9
P1-29	AVSM	Auto Low-frequency Vibration Suppression Mode Selection	0	N/A	O	O			6.2.9
P1-30	VCL	Low-frequency Vibration Detection Level	500	pulse	O	O			6.2.9
P1-34	TACC	Acceleration Time	200	msec		O	O		6.3.3
P1-35	TDEC	Deceleration Time	200	msec		O	O		6.3.3
P1-36	TSL	Accel /Decel S-curve	0	msec		O	O		6.3.3
P1-59	MFLT	Analog Speed Linear Filter (Moving Filter)	0	0.1 ms			O		-
P1-62	FRCL	Friction Compensation Percentage	0	%	O	O	O	O	-
P1-63	FRCT	Friction Compensation Smooth Constant	0	ms	O	O	O	O	-
P1-68	PFLT2	Position Command Moving Filter	0	ms	O	O			-
P1-75	FELP	Full-closed Loop Low-pass Filter Time Constant	100	msec	O	O			-
P2-23	NCF1	Notch Filter 1 (Resonance Suppression)	1000	Hz	O	O	O	O	6.3.7
P2-24	DPH1	Notch Filter Attenuation Rate 1 (Resonance Suppression)	0	dB	O	O	O	O	6.3.7
P2-43	NCF2	Notch Filter 2 (Resonance Suppression)	1000	Hz	O	O	O	O	6.3.7
P2-44	DPH2	Notch Filter Attenuation Rate 2 (Resonance Suppression)	0	dB	O	O	O	O	6.3.7

Smooth Filter and Resonance Suppression									
Parameter	Name	Function	Default	Unit	Control Mode				Related Section
					PT	PR	S	T	
P2-45	NCF3	Notch Filter 3 (Resonance Suppression)	1000	Hz	O	O	O	O	6.3.7
P2-46	DPH3	Notch Filter Attenuation Rate 3 (Resonance Suppression)	0	dB	O	O	O	O	6.3.7
P2-47	ANCF	Auto Resonance Suppression Mode Selection	1	N/A	O	O	O	O	-
P2-48	ANCL	Auto Resonance Suppression Detection Level	100	N/A	O	O	O	O	-
P2-25	NLP	Low-pass Filter Time Constant (Resonance Suppression)	2 or 5	msec	O	O	O	O	6.3.7
P2-33▲	INF	Semi-Auto Mode Inertia Adjustment Selection	0	N/A	O	O	O	O	6.3.6
P2-49	SJIT	Speed Detection Filter and Jitter Suppression	0	sec	O	O	O	O	-

Explanation of symbols (marked after parameter)

- (★) Read-only register.
- (▲) Parameter cannot be set when Servo On (when the servo drive is enabled).
- (●) Parameter is effective only after the servo drive is restarted (after switching power off and on).
- (■) Parameter setting values are not retained when power is off.

Gain and Switch									
Parameter	Name	Function	Default	Unit	Control Mode				Related Section
					PT	PR	S	T	
P2-00	KPP	Proportional Position Loop Gain	35	rad/s	O	O			6.2.8
P2-01	PPR	Position Loop Gain Switching Rate	100	%	O	O			6.2.8
P2-02	PFG	Position Feed Forward Gain	50	%	O	O			6.2.8
P2-03	PFF	Smooth Constant of Position Feed Forward Gain	5	msec	O	O			-
P2-04	KVP	Proportional Speed Loop Gain	500	rad/s	O	O	O	O	6.3.6
P2-05	SPR	Speed Loop Gain Switching Rate	100	%	O	O	O	O	-
P2-06	KVI	Speed Integral Compensation	100	rad/s	O	O	O	O	6.3.6
P2-07	KVF	Speed Feed Forward Gain	0	%	O	O	O	O	6.3.6
P2-26	DST	External Anti-Interference Gain	0	0.001	O	O	O	O	-
P2-27	GCC	Gain Switching Control Selection	0	N/A	O	O	O	O	-
P2-28	GUT	Gain Switching Time Constant	10	10 msec	O	O	O	O	-
P2-29	GPE	Gain Switching Condition	1280000	pulse Kpps r/min	O	O	O	O	-
P2-31 ■	AUT1	Speed Frequency Response Level in Auto and Semi-Auto Mode	80	Hz	O	O	O	O	5.6
									6.3.6
P2-32 ▲	AUT2	Speed Frequency Response Level in Auto and Semi-Auto Mode	0	N/A	O	O	O	O	5.6
									6.3.6

Explanation of symbols (marked after parameter)

- (★) Read-only register.
- (▲) Parameter cannot be set when Servo On (when the servo drive is enabled).
- (●) Parameter is effective only after the servo drive is restarted (after switching power off and on).
- (■) Parameter setting values are not retained when power is off.

Chapter 8 Servo Parameters

ASDA-A2

Position Control									
Parameter	Name	Function	Default	Unit	Control Mode				Related Section
					PT	PR	S	T	
P1-01●	CTL	Control Mode and Output Direction	0	pulse r/min N-M	O	O	O	O	6.1
P1-02▲	PSTL	Speed and Torque Limit	0	N/A	O	O	O	O	6.6
P1-12 ~ P1-14	TQ1 ~ 3	1st ~ 3rd Torque Limit	100	%	O	O	O	O	6.4.1
P1-46▲	GR3	Encoder Output Pulse Number	2500	pulse	O	O	O	O	-
P1-55	MSPD	Maximum Speed Limit	rated	r/min	O	O	O	O	-
P1-72	FRES	Full-closed Loop Resolution	5000	Pulse/ rev	O	O			-
P1-73	FERR	Full-closed Loop Excessive Position Error Range	30000	pulse	O	O			-
P1-74	FCON	Full-closed Loop Control Function Selection	000h	-	O	O			-
P2-50	DCLR	Pulse Deviation Clear Mode	0	N/A	O	O			-
External Pulse Control Command (PT mode)									
P1-00▲	PTT	External Pulse Input Type	0x2	N/A	O				6.2.1
P1-44▲	GR1	Electronic Gear Ratio (1st Numerator) (N1)	1	pulse	O	O			6.2.5
P1-45▲	GR2	Electronic Gear Ratio (Denominator) (M)	1	pulse	O	O			6.3.6
P2-60▲	GR4	Electronic Gear Ratio (2nd Numerator) (N2)	1	pulse	O	O			-
P2-61▲	GR5	Electronic Gear Ratio (3rd Numerator) (N3)	1	pulse	O	O			-
P2-62▲	GR6	Electronic Gear Ratio (4th Numerator) (N4)	1	pulse	O	O			-
Internal Pulse Control Command (PR mode)									
P6-02 ~ P7-27	PO1 ~ PO63	Definition of Path 1 ~ 63 Data of Path 1 ~ 63	0	N/A		O			7.10
P5-60 ~ P5-75	POV1 ~ POV15	Moving Speed Setting of Position 0 ~ 15	20 ~ 3000	0.1 r/min		O			7.10
P5-03	PDEC	Deceleration Time of Protectin Function	0XF00F FFFF	N/A	O	O	O	O	-
P5-04	HMOV	Homing Mode	0	N/A	O	O			-
P5-05	HSPD1	1st Speed Setting of High Speed Homing	100	0.1 r/min	O	O	O	O	-
P5-06	HSPD2	2nd Speed Setting of Low Speed Homing	20	0.1 r/min	O	O	O	O	-
P5-07■	PRCM	Trigger Position Command (PR mode only)	0	N/A		O			-

Position Control									
Parameter	Name	Function	Default	Unit	Control Mode				Related Section
					PT	PR	S	T	
P5-20 ~ P5-35	AC0 ~ AC15	Accel / Decel Time 0 ~ 13	200 ~ 30	ms		O			7.10
P5-40 ~ P5-55	DLY0 ~ DLY15	Delay Time 0 ~ 15	0 ~ 5500	ms		O			7.10
P5-98	EVON	Event Rising-edge Trigger Command (OFF → ON)	0	N/A		O			-
P5-99	EVOF	Event Falling-edge Trigger Command (ON → OFF)	0	N/A		O			-
P5-15■	PMEM	PATH 1 ~ PATH 2 Data Not Retained Setting	0x0	N/A	O	O	O	O	-
P5-16■	AXEN	Axis Position: Motor Encoder	N/A	N/A	O	O	O	O	7.3
P5-17	AXAU	Axis Position: Auxiliary Encoder (Pulse Command Feedback)	N/A	N/A	O	O	O	O	7.3
P5-18	AXPC	Axis Position: Pulse Command	N/A	N/A	O	O	O	O	7.3
P5-08	SWLP	Forward Software Limit	+2 ³¹	PUU		O			-
P5-09	SWLN	Reverse Software Limit	-2 ³¹	PUU		O			-

Explanation of symbols (marked after parameter)

- (★) Read-only register.
- (▲) Parameter cannot be set when Servo On (when the servo drive is enabled).
- (●) Parameter is effective only after the servo drive is restarted (after switching power off and on).
- (■) Parameter setting values are not retained when power is off.

Speed Control									
Parameter	Name	Function	Default	Unit	Control Mode				Related Section
					PT	PR	S	T	
P1-01 ●	CTL	Control Mode and Output Direction	0	pulse r/min N-M	O	O	O	O	6.1
P1-02 ▲	PSTL	Speed and Torque Limit	0	N/A	O	O	O	O	6.6
P1-46 ▲	GR3	Encoder Output Pulse Number	1	pulse	O	O	O	O	-
P1-55	MSPD	Maximum Speed Limit	rated	r/min	O	O	O	O	-
P1-09 ~ P1-11	SP1 ~ 3	1st ~ 3rd Speed Command	1000 ~ 3000	0.1 r/min			O	O	6.3.1
P1-12 ~ P1-14	TQ1 ~ 3	1st ~ 3rd Torque Limit	100	%	O	O	O	O	6.6.2
P1-40 ▲	VCM	Max. Analog Speed Command or Limit	rated	r/min			O	O	6.3.4
P1-41 ▲	TCM	Max. Analog Torque Command or Limit	100	%	O	O	O	O	-
P1-76	AMSPD	Max. Rotation Speed of Encoder Output	5500	r/min	O	O	O	O	-

Explanation of symbols (marked after parameter)

- (★) Read-only register.
- (▲) Parameter cannot be set when Servo On (when the servo drive is enabled).
- (●) Parameter is effective only after the servo drive is restarted (after switching power off and on).
- (■) Parameter setting values are not retained when power is off.

Torque Control									
Parameter	Name	Function	Default	Unit	Control Mode				Related Section
					PT	PR	S	T	
P1-01 ●	CTL	Control Mode and Output Direction	0	pulse r/min N-M	O	O	O	O	6.1
P1-02 ▲	PSTL	Speed and Torque Limit	0	N/A	O	O	O	O	6.6
P1-46 ▲	GR3	Encoder Output Pulse Number	1	pulse	O	O	O	O	-
P1-55	MSPD	Maximum Speed Limit	rated	r/min	O	O	O	O	-
P1-09 ~ P1-11	SP1~3	1st ~ 3rd Speed Limit	100 ~ 300	r/min			O	O	6.6.1
P1-12 ~ P1-14	TQ1~3	1st ~ 3rd Torque Command	100	%	O	O	O	O	6.4.1
P1-40 ▲	VCM	Max. Analog Speed Command or Limit	rated	r/min			O	O	-
P1-41 ▲	TCM	Max. Analog Torque Command or Limit	100	%	O	O	O	O	6.4.4

Explanation of symbols (marked after parameter)

- (★) Read-only register.
- (▲) Parameter cannot be set when Servo On (when the servo drive is enabled).
- (●) Parameter is effective only after the servo drive is restarted (after switching power off and on).
- (■) Parameter setting values are not retained when power is off.

Chapter 8 Servo Parameters

ASDA-A2

Digital I/O and Relative Input Output Setting									
Parameter	Name	Function	Default	Unit	Control Mode				Related Section
					PT	PR	S	T	
P2-09	DRT	Bounce Filter	2	2msec	0	0	0	0	-
P2-10	DI1	Digital Input Terminal 1 (DI1)	101	N/A	0	0	0	0	Table 8.A
P2-11	DI2	Digital Input Terminal 2 (DI2)	104	N/A	0	0	0	0	Table 8.A
P2-12	DI3	Digital Input Terminal 3 (DI3)	116	N/A	0	0	0	0	Table 8.A
P2-13	DI4	Digital Input Terminal 4 (DI4)	117	N/A	0	0	0	0	Table 8.A
P2-14	DI5	Digital Input Terminal 5 (DI5)	102	N/A	0	0	0	0	Table 8.A
P2-15	DI6	Digital Input Terminal 6 (DI6)	22	N/A	0	0	0	0	Table 8.A
P2-16	DI7	Digital Input Terminal 7 (DI7)	23	N/A	0	0	0	0	Table 8.A
P2-17	DI8	Digital Input Terminal 8 (DI8)	21	N/A	0	0	0	0	Table 8.A
P2-36	EDI9	External Digital Input Terminal 9 (EDI9)	0	N/A	0	0	0	0	Table 8.A
P2-37	EDI10	External Digital Input Terminal 10 (EDI10)	0	N/A	0	0	0	0	Table 8.A
P2-38	EDI11	External Digital Input Terminal 11 (EDI11)	0	N/A	0	0	0	0	Table 8.A
P2-39	EDI12	External Digital Input Terminal 12 (EDI12)	0	N/A	0	0	0	0	Table 8.A
P2-40	EDI13	External Digital Input Terminal 13 (EDI13)	0	N/A	0	0	0	0	Table 8.A
P2-41	EDI14	External Digital Input Terminal 14 (EDI14)	0	N/A	0	0	0	0	Table 8.A
P2-18	DO1	Digital Output Terminal 1 (DO1)	101	N/A	0	0	0	0	Table 8.B
P2-19	DO2	Digital Output Terminal 2 (DO2)	103	N/A	0	0	0	0	Table 8.B
P2-20	DO3	Digital Output Terminal 3 (DO3)	109	N/A	0	0	0	0	Table 8.B
P2-21	DO4	Digital Output Terminal 4 (DO4)	105	N/A	0	0	0	0	Table 8.B
P2-22	DO5	Digital Output Terminal 5 (DO5)	7	N/A	0	0	0	0	Table 8.B
P1-38	ZSPD	Zero Speed Range Setting	100	0.1 r/min	0	0	0	0	Table 8.B
P1-39	SSPD	Target Motor Speed	3000	r/min	0	0	0	0	Table 8.B
P1-42	MBT1	On Delay Time of Electromagnetic Brake	0	ms	0	0	0	0	6.5.5

Digital I/O and Relative Input Output Setting

Parameter	Name	Function	Default	Unit	Control Mode				Related Section
					PT	PR	S	T	
P1-43	MBT2	OFF Delay Time of Electromagnetic Brake	0	ms	O	O	O	O	6.5.5
P1-47	SCPD	Speed Reached Output Range	10	r/min			O		Table 8.B
P1-54	PER	Positioning Completed Width	12800	pulse	O	O			Table 8.B
P1-56	OVW	Output Overload Warning Time	120	%	O	O	O	O	Table 8.B

Communication

Parameter	Name	Function	Default	Unit	Control Mode				Related Section
					PT	PR	S	T	
P3-00●	ADR	Communication Address Setting	0x7F	N/A	O	O	O	O	9.2
P3-01	BRT	Transmission Speed	0x0203	bps	O	O	O	O	9.2
P3-02	PTL	Communication Protocol	6	N/A	O	O	O	O	9.2
P3-03	FLT	Transmission Fault Treatment	0	N/A	O	O	O	O	9.2
P3-04	CWD	Communication Time Out Detection	0	sec	O	O	O	O	9.2
P3-05	CMM	Communication Selection	0	N/A	O	O	O	O	9.2
P3-06■	SDI	Digital Input Communication Function	0	N/A	O	O	O	O	9.2
P3-07	CDT	Communication Response Delay Time	0	1ms	O	O	O	O	9.2
P3-08■	MNS	Monitor Mode	0000	N/A	O	O	O	O	9.2
P3-09	SYC	CANopen Synchronization Setting	0x57A1	N/A	O	O	O	O	9.2

Explanation of symbols (marked after parameter)

- (★) Read-only register.
- (▲) Parameter cannot be set when Servo On (when the servo drive is enabled).
- (●) Parameter is effective only after the servo drive is restarted (after switching power off and on).
- (■) Parameter setting values are not retained when power is off.

Chapter 8 Servo Parameters

ASDA-A2

Diagnosis									
Parameter	Name	Function	Default	Unit	Control Mode				Related Section
					PT	PR	S	T	
P4-00★	ASH1	Fault Record (N)	0	N/A	O	O	O	O	4.4.1
P4-01★	ASH2	Fault Record (N-1)	0	N/A	O	O	O	O	4.4.1
P4-02★	ASH3	Fault Record (N-2)	0	N/A	O	O	O	O	4.4.1
P4-03★	ASH4	Fault Record (N-3)	0	N/A	O	O	O	O	4.4.1
P4-04★	ASH5	Fault Record (N-4)	0	N/A	O	O	O	O	4.4.1
P4-05	JOG	JOG Operation	20	r/min	O	O	O	O	4.4.2
P4-06▲■	FOT	Force Output Contact Control	0	N/A	O	O	O	O	4.4.4
P4-07	ITST	Input Status	0	N/A	O	O	O	O	4.4.5 9.2
P4-08★	PKEY	Digital Keypad Input of Servo Drive	N/A	N/A	O	O	O	O	-
P4-09★	MOT	Output Status	N/A	N/A	O	O	O	O	4.4.6
P4-10▲	CEN	Adjustment Function	0	N/A	O	O	O	O	-
P4-11	SOF1	Analog Speed Input Drift Adjustment 1	Factory Setting	N/A	O	O	O	O	-
P4-12	SOF2	Analog Speed Input Drift Adjustment 2	Factory Setting	N/A	O	O	O	O	-
P4-13	TOF1	Analog Torque Drift Adjustment 1	Factory Setting	N/A	O	O	O	O	-
P4-14	TOF2	Analog Torque Drift Adjustment 2	Factory Setting	N/A	O	O	O	O	-
P4-15	COF1	Current Detector Drift Adjustment (V1 phase)	Factory Setting	N/A	O	O	O	O	-
P4-16	COF2	Current Detector Drift Adjustment (V2 phase)	Factory Setting	N/A	O	O	O	O	-
P4-17	COF3	Current Detector Drift Adjustment (W1 phase)	Factory Setting	N/A	O	O	O	O	-
P4-18	COF4	Current Detector Drift Adjustment (W2 phase)	Factory Setting	N/A	O	O	O	O	-
P4-19	TIGB	IGBT NTC Calibration	Factory Setting	N/A	O	O	O	O	-
P4-20	DOF1	Analog Monitor Output Drift Adjustment (CH1)	0	mV	O	O	O	O	6.4.4
P4-21	DOF2	Analog Monitor Output Drift Adjustment (CH2)	0	mV	O	O	O	O	6.4.4
P4-22	SAO	Analog Speed Input Offset	0	mV			O		-
P4-23	TAO	Analog Torque Input Offset	0	mV				O	-
P4-24	LVL	Undervoltage Error Level	160	V(rms)	O	O	O	O	-

E-Cam Function									
Parameter	Name	Function	Default	Unit	Control Mode				Related Section
					PT	PR	S	T	
P5-81	ECHD	E-Cam: Start Address of Data Array	100	N/A	O	O	O	O	7.10
P5-82	ECMN	E-Cam: E-Cam Area Number N (at least >=5)	5	N/A		O			7.10
P5-83	ECMM	E-Cam: E-Cam Cycle Number (M)	1	N/A		O			7.10
P5-84	ECMP	E-Cam: Pulse Number of Master Axis (P)	3600	N/A		O			7.10
P5-85	ECME	E-Cam: Engage Area Number	0	N/A		O			7.10
P5-86■	ECAX	E-Cam: Position of Master Axis	0	N/A		O			7.10
P5-87	PLED	E-Cam: Lead Command Length	0	N/A		O			7.10
P5-88■	ECON	E-Cam: E-Cam Setting	000000 00h	N/A		O			7.10
P5-89	ECRD	E-Cam: Disengage Timing Data	0	N/A		O			7.10
P5-90	CMAP	E-Cam: Area Number + (Polarity is Positive)	0	N/A		O			7.10
P5-91	CMAN	E-Cam: Area Number - (Polarity is Negative)	0	N/A		O			7.10
P5-92	PLED	E-Cam: Cyclic Lead Command Length	0	N/A		O			7.10

Explanation of symbols (marked after parameter)

- (★) Read-only register.
- (▲) Parameter cannot be set when Servo On (when the servo drive is enabled).
- (●) Parameter is effective only after the servo drive is restarted (after switching power off and on).
- (■) Parameter setting values are not retained when power is off.

8.3 Detailed Parameter Listings

Group 0: P0-xx Monitor Parameters

P0 - 00★	VER	Firmware Version	Address: 0000H, 0001H
-----------------	------------	-------------------------	------------------------------

Default: Factory setting

Related Section: N/A

Applicable Control Mode: ALL

Unit: N/A

Range: N/A

Data Size: 16-bit

Display Format: Decimal

P0 - 01■	ALE	Drive Fault Code	Address: 0002H, 0003H
-----------------	------------	-------------------------	------------------------------

Default: N/A

Related Section: Chapter 11

Applicable Control Mode: ALL

Unit: N/A

Range: 001 ~ 380

Data Size: 16-bit

Display Format: BCD

Settings:

This parameter shows the current servo drive fault if the servo drive is currently faulted. The fault code is hexadecimal data but displayed in BCD format (Binary coded decimal).

Servo Drive Fault Codes:

001: Overcurrent

002: Overvoltage

003: Undervoltage (This fault code shows when main circuit voltage is below its minimum specified value while Servo On, and it will not show while Servo Off. This fault code can't be cleared automatically after the voltage has returned within its specification. Please refer to parameter P2-66.)

004: Motor error (The drive and motor are not correctly matched for size (power rating).)

005: Regeneration error

006: Overload

007: Overspeed

008: Abnormal pulse control command

009: Excessive deviation

010: Reserved

011: Encoder error (The wiring of the encoder is in error and this causes the communication error between the servo drive and the encoder.)

012: Adjustment error

- 013: Emergency stop activated
- 014: Reverse limit switch error
- 015: Forward limit switch error
- 016: IGBT temperature error
- 017: Memory error
- 018: Encoder output error
- 019: Serial communication error
- 020: Serial communication time out
- 021: Reserved
- 022: Input power phase loss
- 023: Pre-overload warning
- 024: Encoder initial magnetic field error
- 025: Encoder internal error
- 026: Encoder data error
- 030: Motor protection error
- 031: U, V, W wiring error
- 040: Full-closed loop excessive deviation
- 099: DSP firmware upgrade

CANopen Communication Fault Codes

- 185: CANbus error
- 111: CANopen SDO receive buffer overrun
- 112: CANopen PDO receive buffer overrun
- 121: Index error occurs when accessing CANopen PDO object.
- 122: Sub-index error occurs when accessing CANopen PDO object.
- 123: Data type (size) error occurs when accessing CANopen PDO object.
- 124: Data range error occurs when accessing CANopen PDO object.
- 125: CANopen PDO object is read-only and write-protected.
- 126: CANopen PDO object does not support PDO.
- 127: CANopen PDO object is write-protected when Servo On.
- 128: Error occurs when reading CANopen PDO object from EE-PROM.
- 129: Error occurs when writing CANopen PDO object into EE-PROM.
- 130: EE-PROM invalid address range
- 131: EE-PROM checksum error
- 132: Password error

Motion Control Fault Codes:

- 201: CANopen data initial error
- 213: Write parameter error: exceeds the limit of normal range
- 215: Write parameter error: read only

- 217: Write parameter error: parameter lock
- 219: Write parameter error: parameter lock
- 235: PR command overflow
- 245: PR positioning time out
- 249: Invalid PR path number
- 261: Index error occurs when accessing CANopen object.
- 263: Sub-index error occurs when accessing CANopen object.
- 265: Data type (size) error occurs when accessing CANopen object.
- 267: Data range error occurs when accessing CANopen object.
- 269: CANopen object is read-only and write-protected.
- 26b: CANopen object does not support PDO.
- 26d: CANopen object is write-protected when Servo On.
- 26F: Error occurs when reading CANopen object from EE-PROM.
- 271: Error occurs when writing CANopen object into EE-PROM.
- 273: EE-PROM invalid address range
- 275: EE-PROM checksum error
- 277: Password error
- 283: Forward software limit
- 285: Reverse software limit
- 289: Position counter overflow
- 291: Servo Off error
- 301: CANopen SYNC failed
- 302: CANopen SYNC signal error
- 303: CANopen SYNC time out
- 304: CANopen IP command failed
- 305: SYNC period error
- 380: Position deviation alarm for digital output, MC_OK (Please refer to P1-48.)

P0 - 02	STS	Drive Status (Front Panel Display)	Address: 0004H, 0005H
----------------	------------	---	------------------------------

Default: 00

Related Section:

Applicable Control Mode: ALL

Section 4.3.5, Section 7.2

Unit: N/A

Range: 00 ~ 127

Data Size: 16-bit

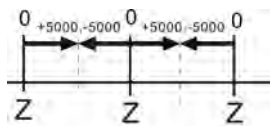
Display Format: Decimal

Settings:

This parameter shows the servo drive status.

00: Motor feedback pulse number (after electronic gear ratio is set) [user unit]

- 01: Input pulse number of pulse command (after electronic gear ratio is set) [user unit]
- 02: Position error counts between control command pulse and feedback pulse [user unit]
- 03: Motor feedback pulse number (encoder unit, 1280000 pulse/rev) [pulse]
- 04: Input pulse number of pulse command (before electronic gear ratio is set) [pulse]
- 05: Position error counts [pulse]
- 06: Input frequency of pulse command [Kpps]
- 07: Motor rotation speed [r/min]
- 08: Speed input command [Volt]
- 09: Speed input command [r/min]
- 10: Torque input command [Volt]
- 11: Torque input command [%]
- 12: Average load [%]
- 13: Peak load [%]
- 14: Main circuit voltage [Volt]
- 15: Ratio of load inertia to Motor inertia [0.1times]
- 16: IGBT temperature
- 17: Resonance frequency [Hz]
- 18: Absolute pulse number relative to encoder (use Z phase as home). The value of Z phase home point is 0, and it can be the value from -5000 to +5000 pulses.



- 19: Mapping Parameter 1: Display the content of parameter P0-25 (mapping target is specified by parameter P0-35)
- 20: Mapping Parameter 2: Display the content of parameter P0-26 (mapping target is specified by parameter P0-36)
- 21: Mapping Parameter 3: Display the content of parameter P0-27 (mapping target is specified by parameter P0-37)
- 22: Mapping Parameter 4: Display the content of parameter P0-28 (mapping target is specified by parameter P0-38)
- 23: Status Monitor 1: Display the content of parameter P0-09 (the monitor status is specified by parameter P0-17)
- 24: Status Monitor 2: Display the content of parameter P0-10 (the monitor status is specified by parameter P0-18)
- 25: Status Monitor 3: Display the content of parameter P0-11 (the monitor status is specified by parameter P0-19)
- 26: Status Monitor 4: Display the content of parameter P0-12 (the monitor status is specified by parameter P0-20)

Chapter 8 Servo Parameters

ASDA-A2

P0 - 03	MON	Analog Monitor Output	Address: 0006H, 0007H
----------------	------------	------------------------------	------------------------------

Default: 01

Related Section:

Applicable Control Mode: ALL

Section 4.3.5

Unit: N/A

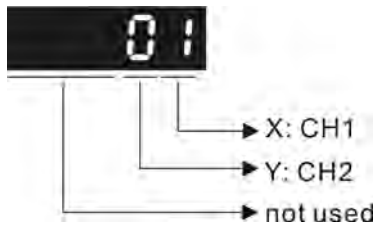
Range: 00 ~ 77

Data Size: 16-bit

Display Format: Hexadecimal

Settings:

This parameter determines the functions of the analog monitor outputs.



XY: (X: CH1; Y: CH2)

- 0: Motor speed (+/-8V / maximum motor speed)
- 1: Motor torque (+/-8V / maximum torque)
- 2: Pulse command frequency (+8Volts / 4.5Mpps)
- 3: Speed command (+/-8Volts / maximum speed command)
- 4: Torque command (+/-8Volts / maximum torque command)
- 5: V_BUS voltage (+/-8Volts / 450V)
- 6: Reserved
- 7: Reserved

Please note: For the setting of analog output voltage proportion, refer to the P1-04 and P1-05.

Example:

P0-03 = 01(CH1 is speed analog output)

Motor speed = (Max. motor speed × V1/8) × P1-04/100, when the output voltage value of CH1 is V1.

P0 - 04	Reserved (Do Not Use)
P0 - 05	Reserved (Do Not Use)
P0 - 06	Reserved (Do Not Use)
P0 - 07	Reserved (Do Not Use)

ASDA-A2**Chapter 8 Servo Parameters**

P0 - 08★	TSON	Servo Startup Time	Address: 0010H, 0011H
-----------------	-------------	---------------------------	------------------------------

Default: 0

Related Section: N/A

Applicable Control Mode: ALL

Unit: Hour

Range: 0 ~ 65535

Data Size: 16-bit

Display Format: Decimal

P0 - 09★	CM1	Status Monitor 1	Address: 0012H, 0013H
-----------------	------------	-------------------------	------------------------------

Default: N/A

Related Section:

Applicable Control Mode: ALL

Section 4.3.5

Unit: N/A

Range: N/A

Data Size: 32-bit

Display Format: Decimal

Settings:

This parameter is used to provide the value of one of the status monitoring functions found in P0-02. The value of P0-09 is determined by P0-17 (desired drive status) through communication setting or the keypad. The drive status can be read from the communication address of this parameter via communication port.

For example:

Set P0-17 to 3, then all consequent reads of P0-09 will return the motor feedback pulse number in pulse.

When reading the drive status through Modbus communication, the system should read two 16-bit data stored in the addresses of 0012H and 0013H to form a 32-bit data.

(0013H : 0012H) = (High Word : Low Word)

When reading the drive status through the keypad, if P0-02 is set to 23, VAR-1 will quickly show for about two seconds and then the value of P0-09 will display on the display.

P0 - 10★	CM2	Status Monitor 2	Address: 0014H, 0015H
-----------------	------------	-------------------------	------------------------------

Default: N/A

Related Section:

Applicable Control Mode: ALL

Section 4.3.5

Unit: N/A

Range: N/A

Data Size: 32-bit

Display Format: Decimal

Settings:

This parameter is used to provide the value of one of the status monitoring functions found in P0-02. The value of P0-10 is determined by P0-18 (desired drive status) through communication setting or the keypad. The drive status can be read from the communication address of this parameter via communication port.

When reading the drive status through the keypad, if P0-02 is set to 24, VAR-2 will quickly show for about two seconds and then the value of P0-10 will display on the display.

P0 - 11★	CM3	Status Monitor 3	Address: 0016H, 0017H
-----------------	------------	-------------------------	------------------------------

Default: N/A

Related Section:

Applicable Control Mode: ALL

Section 4.3.5

Unit: N/A

Range: N/A

Data Size: 32-bit

Display Format: Decimal

Settings:

This parameter is used to provide the value of one of the status monitoring functions found in P0-02. The value of P0-11 is determined by P0-19 (desired drive status) through communication setting or the keypad. The drive status can be read from the communication address of this parameter via communication port.

When reading the drive status through the keypad, if P0-02 is set to 25, VAR-3 will quickly show for about two seconds and then the value of P0-11 will display on the display.

P0 - 12★	CM4	Status Monitor 4	Address: 0018H, 0019H
-----------------	------------	-------------------------	------------------------------

Default: N/A

Related Section:

Applicable Control Mode: ALL

Section 4.3.5

Unit: N/A

Range: N/A

Data Size: 32-bit

Display Format: Decimal

Settings:

This parameter is used to provide the value of one of the status monitoring functions found in P0-02. The value of P0-12 is determined by P0-20 (desired drive status) through communication setting or the keypad. The drive status can be read from the communication address of this parameter via communication port.

When reading the drive status through the keypad, if P0-02 is set to 26, VAR-4 will quickly show for about two seconds and then the value of P0-12 will display on the display.

ASDA-A2**Chapter 8 Servo Parameters**

P0 - 13★	CM5	Status Monitor 5	Address: 001AH, 001BH
-----------------	------------	-------------------------	------------------------------

Default: N/A

Related Section:

Applicable Control Mode: ALL

Section 4.3.5

Unit: N/A

Range: N/A

Data Size: 32-bit

Display Format: Decimal

Settings:

This parameter is used to provide the value of one of the status monitoring functions found in P0-02. The value of P0-12 is determined by P0-20 (desired drive status) through communication setting or the keypad. The drive status can be read from the communication address of this parameter via communication port.

P0 - 14	Reserved (Do Not Use)		
P0 - 15	Reserved (Do Not Use)		
P0 - 16	Reserved (Do Not Use)		

P0 - 17	CM1A	Status Monitor Selection 1	Address: 0022H, 0023H
----------------	-------------	-----------------------------------	------------------------------

Default: 0

Related Section: N/A

Applicable Control Mode: ALL

Unit: N/A

Range: 0 ~ 127

Data Size: 16-bit

Display Format: Decimal

Settings:

This parameter is used to determine the drive status found in P0-02. The selected drive status will be displayed by P0-09.

For example:

Set P0-17 to 7, then all consequent reads of P0-09 will return the motor rotation speed in r/min.

Chapter 8 Servo Parameters**ASDA-A2**

P0 - 18	CM2A	Status Monitor Selection 2	Address: 0024H, 0025H
----------------	-------------	-----------------------------------	------------------------------

Default: 0

Related Section: N/A

Applicable Control Mode: ALL

Unit: N/A

Range: 0 ~ 127

Data Size: 16-bit

Display Format: Decimal

Settings:

This parameter is used to determine the drive status found in P0-02. The selected drive status will be displayed by P0-10. Refer to P0-17 for explanation.

P0 - 19	CM3A	Status Monitor Selection 3	Address: 0026H, 0027H
----------------	-------------	-----------------------------------	------------------------------

Default: 0

Related Section: N/A

Applicable Control Mode: ALL

Unit: N/A

Range: 0 ~ 127

Data Size: 16-bit

Display Format: Decimal

Settings:

This parameter is used to determine the drive status found in P0-02. The selected drive status will be displayed by P0-11. Refer to P0-17 for explanation.

P0 - 20	CM4A	Status Monitor Selection 4	Address: 0028H, 0029H
----------------	-------------	-----------------------------------	------------------------------

Default: 0

Related Section: N/A

Applicable Control Mode: ALL

Unit: N/A

Range: 0 ~ 127

Data Size: 16-bit

Display Format: Decimal

Settings:

This parameter is used to determine the drive status found in P0-02. The selected drive status will be displayed by P0-12. Refer to P0-17 for explanation.

ASDA-A2**Chapter 8 Servo Parameters**

P0 - 21	CM5A	Status Monitor Selection 5	Address: 002AH, 002BH
----------------	-------------	-----------------------------------	------------------------------

Default: 0

Related Section: N/A

Applicable Control Mode: ALL

Unit: N/A

Range: 0 ~ 127

Data Size: 16-bit

Display Format: Decimal

Settings:

This parameter is used to determine the drive status found in P0-02. The selected drive status will be displayed by P0-13. Refer to P0-17 for explanation.

P0 - 22	Reserved (Do Not Use)		
P0 - 23	Reserved (Do Not Use)		
P0 - 24	Reserved (Do Not Use)		

P0 - 25	MAP1	Mapping Parameter 1	Address: 0032H, 0033H
----------------	-------------	----------------------------	------------------------------

Default: N/A

Related Section:

Applicable Control Mode: ALL

Section 4.3.5

Unit: N/A

Range: determined by the parameter specified by P0-35

Data Size: 32-bit

Display Format: Hexadecimal

Settings:

The parameters from P0-25 to P0-32 are used to read and write the values of the parameters those communication addresses are not consecutive. The users can set P0-35 ~ P0-42 as the desired read and write mapping parameter numbers through communication setting or the keypad. When reading or writing P0-25 ~ P0-32, the read or write values are equivalent to the values of the parameters specified by P0-35 ~ P0-42, and vice versa. Refer to P0-35 for explanation.

Chapter 8 Servo Parameters**ASDA-A2**

P0 - 26	MAP2	Mapping Parameter 2	Address: 0034H, 0035H
----------------	-------------	----------------------------	------------------------------

Default: N/A

Related Section:

Applicable Control Mode: ALL

Section 4.3.5

Unit: N/A

Range: determined by the parameter specified by P0-36

Data Size: 32-bit

Display Format: Hexadecimal

Settings:

Refer to P0-25 and P0-36 for explanation.

P0 - 27	MAP3	Mapping Parameter 3	Address: 0036H, 0037H
----------------	-------------	----------------------------	------------------------------

Default: N/A

Related Section:

Applicable Control Mode: ALL

Section 4.3.5

Unit: N/A

Range: determined by the parameter specified by P0-37

Data Size: 32-bit

Display Format: Hexadecimal

Settings:

Refer to to P0-25 and P0-37 for explanation.

P0 - 28	MAP4	Mapping Parameter 4	Address: 0038H, 0039H
----------------	-------------	----------------------------	------------------------------

Default: N/A

Related Section:

Applicable Control Mode: ALL

Section 4.3.5

Unit: N/A

Range: determined by the parameter specified by P0-38

Data Size: 32-bit

Display Format: Hexadecimal

Settings:

Refer to P0-25 and P0-38 for explanation.

ASDA-A2**Chapter 8 Servo Parameters**

P0 - 29	MAP5	Mapping Parameter 5	Address: 003AH, 003BH
----------------	-------------	----------------------------	------------------------------

Default: N/A

Related Section:

Applicable Control Mode: ALL

Section 4.3.5

Unit: N/A

Range: determined by the parameter specified by P0-39

Data Size: 32-bit

Display Format: Hexadecimal

Settings:

Refer to P0-25 and P0-39 for explanation.

P0 - 30	MAP6	Mapping Parameter 6	Address: 003CH, 003DH
----------------	-------------	----------------------------	------------------------------

Default: N/A

Related Section:

Applicable Control Mode: ALL

Section 4.3.5

Unit: N/A

Range: determined by the parameter specified by P0-40

Data Size: 32-bit

Display Format: Hexadecimal

Settings:

Refer to P0-25 and P0-40 for explanation.

P0 - 31	MAP7	Mapping Parameter 7	Address: 003EH, 003FH
----------------	-------------	----------------------------	------------------------------

Default: N/A

Related Section:

Applicable Control Mode: ALL

Section 4.3.5

Unit: N/A

Range: determined by the parameter specified by P0-41

Data Size: 32-bit

Display Format: Hexadecimal

Settings:

Refer to P0-25 and P0-41 for explanation.

Chapter 8 Servo Parameters

ASDA-A2

P0 - 32	MAP8	Mapping Parameter 8	Address: 0040H, 0041H
----------------	-------------	----------------------------	------------------------------

Default: N/A

Related Section:

Applicable Control Mode: ALL

Section 4.3.5

Unit: N/A

Range: determined by the parameter specified by P0-42

Data Size: 32-bit

Display Format: Hexadecimal

Settings:

Refer to P0-25 and P0-42 for explanation.

P0 - 33	Reserved (Do Not Use)		
P0 - 34	Reserved (Do Not Use)		

P0 - 35	MAP1A	Block Data Read / Write Register 1 (for P0-25)	Address: 0046H, 0047H
----------------	--------------	---	------------------------------

Default: 0x0

Related Section:

Applicable Control Mode: ALL

Section 4.3.5

Unit: N/A

Range: determined by the communication address of the designated parameter

Data Size: 32-bit

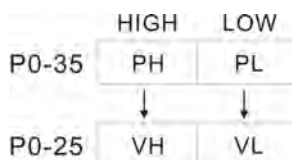
Display Format: Hexadecimal

Settings:

The parameters from P0-35 to P0-42 are used to designate the desired read and write parameter numbers for P0-25 to P0-32, and read and write the values of the parameters those communication addresses are not consecutive through communication setting or the keypad more efficiently.

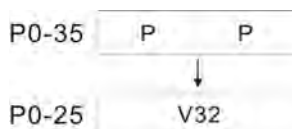
The read / write parameter could be one 32-bit parameter or two 16-bit parameters.

The operation of parameter P0-35 is described as follows:



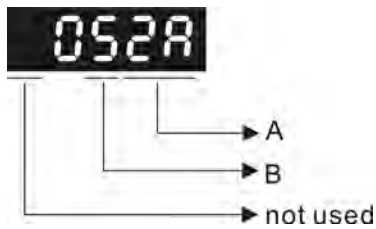
When PH ≠ PL, it indicates that P0-25 includes two 16-bit parameters.

VH = *(PH) VL = *(PL)



When PH = PL = P, it indicates that the content of P0-25 is one 32-bit parameter.

V32 = *(P). If P = 060Ah (parameter P6-10), the value of V32 is the value of P6-10.



A: Parameter group code in hexadecimal format

B: Parameter number in hexadecimal format

For example:

If the desired read and write parameter number is P2-06, please set P0-35 to 0206. If the desired read and write parameter number is P5-42, please set P0-35 to 052A, and vice versa.

When the users want to read and write the value of the parameter P1-44 (32-bit parameter) via P0-25, please set P0-35 to 0x012C012C through communication setting or the keypad. The the value of the parameter P1-44 will be displayed by P0-25.

When the users want to read and write the values of the parameters P2-02 (Position Feed Forward Gain, 16-bit parameter) and P2-04 (Proportional Speed Loop Gain, 16-bit parameter) via P0-25, please set P0-35 to 0x02040202 through communication setting or the keypad. The the values of the parameters P2-02 and P2-04 will be displayed by P0-25.

P0 - 36**MAP2A****Block Data Read / Write Register 2 (for P0-26)****Address: 0048H, 0049H**

Default: 0x0

Related Section:

Applicable Control Mode: ALL

Section 4.3.5

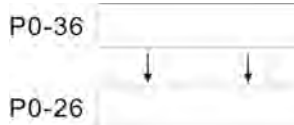
Unit: N/A

Range: determined by the communication address of the designated parameter

Data Size: 32-bit

Display Format: Hexadecimal

Settings:



Refer to P0-35 for explanation.

Chapter 8 Servo Parameters

ASDA-A2

P0 - 37	MAP3A	Block Data Read / Write Register 3 (for P0-27)	Address: 004AH, 004BH
----------------	--------------	---	------------------------------

Default: 0x0

Related Section:

Applicable Control Mode: ALL

Section 4.3.5

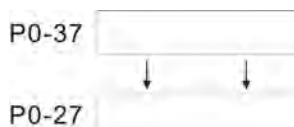
Unit: N/A

Range: determined by the communication address of the designated parameter

Data Size: 32-bit

Display Format: Hexadecimal

Settings:



Refer to P0-35 for explanation.

P0 - 38	MAP4A	Block Data Read / Write Register 4 (for P0-28)	Address: 004CH, 004DH
----------------	--------------	---	------------------------------

Default: 0x0

Related Section:

Applicable Control Mode: ALL

Section 4.3.5

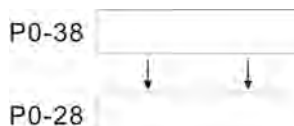
Unit: N/A

Range: determined by the communication address of the designated parameter

Data Size: 32-bit

Display Format: Hexadecimal

Settings:



Refer to P0-35 for explanation.

P0 - 39	MAP5A	Block Data Read / Write Register 5 (for P0-29)	Address: 004EH, 004FH
----------------	--------------	---	------------------------------

Default: 0x0

Related Section:

Applicable Control Mode: ALL

Section 4.3.5

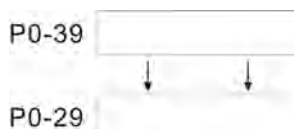
Unit: N/A

Range: determined by the communication address of the designated parameter

Data Size: 32-bit

Display Format: Hexadecimal

Settings:



Refer to P0-35 for explanation.

ASDA-A2**Chapter 8 Servo Parameters**

P0 - 40	MAP6A	Block Data Read / Write Register 6 (for P0-30)	Address: 0050H, 0051H
----------------	--------------	---	------------------------------

Default: 0x0

Related Section:

Applicable Control Mode: ALL

Section 4.3.5

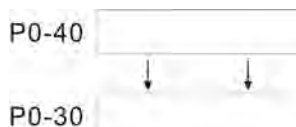
Unit: N/A

Range: determined by the communication address of the designated parameter

Data Size: 32-bit

Display Format: Hexadecimal

Settings:



Refer to P0-35 for explanation.

P0 - 41	MAP7A	Block Data Read / Write Register 7 (for P0-31)	Address: 0052H, 0053H
----------------	--------------	---	------------------------------

Default: 0x0

Related Section:

Applicable Control Mode: ALL

Section 4.3.5

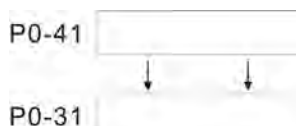
Unit: N/A

Range: determined by the communication address of the designated parameter

Data Size: 32-bit

Display Format: Hexadecimal

Settings:



Refer to P0-35 for explanation.

P0 - 42	MAP8A	Block Data Read / Write Register 8 (for P0-32)	Address: 0054H, 0055H
----------------	--------------	---	------------------------------

Default: 0x0

Related Section:

Applicable Control Mode: ALL

Section 4.3.5

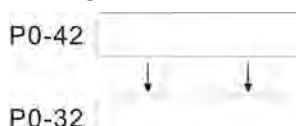
Unit: N/A

Range: determined by the communication address of the designated parameter

Data Size: 32-bit

Display Format: Hexadecimal

Settings:



Refer to P0-35 for explanation.

P0 - 43**Reserved (Do Not Use)****P0 - 44****PCMN****Status Monitor Register (PC Software Setting)****Address: 0058H, 0059H**

Default: 0x0

Related Section:

Applicable Control Mode: ALL

Section 4.3.5

Unit: N/A

Range: determined by the communication address of the designated parameter

Data Size: 32-bit

Display Format: Decimal

Settings:

The function of this parameter is the same as P0-09 (Please refer to P0-09). Please note that this parameter can be set through communication setting only.

P0 - 45**PCMNA****Status Monitor Register Selection (PC Software Setting)****Address: 005AH, 005BH**

Default: 0x0

Related Section:

Applicable Control Mode: ALL

Section 4.3.5

Unit: N/A

Range: 0 ~ 127

Data Size: 16-bit

Display Format: Decimal

Settings:

The function of this parameter is the same as P0-17 (Please refer to P0-17). Please note that this parameter can be set through communication setting only.

P0 - 46★**SVSTS****Servo Output Status Display****Address: 005CH, 005DH**

Default: 0

Related Section: -

Applicable Control Mode: ALL

Unit: N/A

Range: 0x00 ~ 0xFF

Data Size: 16-bit

Display Format: Hexadecimal

Settings:

This parameter is used to display the digital output signal of the servo drive. The servo output status display will show in hexadecimal format.

Bit0: SRDY (Servo ready)

Bit1: SON (Servo On)

Bit2: ZSPD (At Zero speed)

Bit3: TSPD (At Speed reached)

Bit4: TPOS (At Positioning completed)

Bit5: TQL (At Torque limit)

Bit6: ALRM (Servo alarm activated)

Bit7: BRKR (Electromagnetic brake control)

Bit8: HOME (Homing completed)

Bit9: OLW (Output overload warning)

Bit10: WARN (Servo warning activated. WARN is activated when the drive has detected reverse limit error; forward limit error, emergency stop, serial communication error, and undervoltage these fault conditions.)

Bit11: Reserved

Bit12: Reserved

Bit13: Reserved

Bit14: Reserved

Bit15: Reserved

The servo output status display can be monitored through communication also.

Group 1: P1-xx Basic Parameters

P1 - 00▲	PTT	External Pulse Input Type	Address: 0100H, 0101H
-----------------	------------	----------------------------------	------------------------------

Default: 0x2

Related Section:

Applicable Control Mode: PT

Section 6.2.1

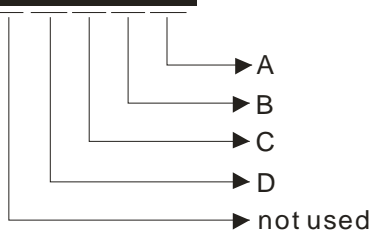
Unit: N/A

Range: 0 ~ 1132

Data Size: 16-bit

Display Format: Hexadecimal

Settings:



A: Input pulse type

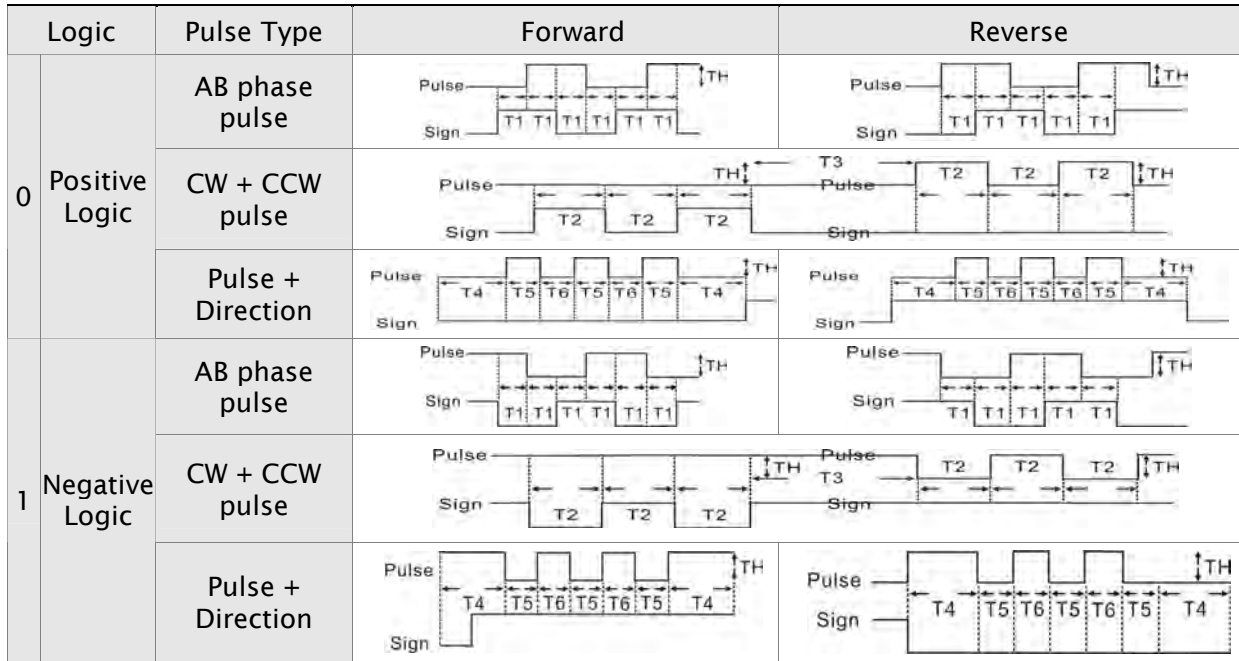
- 0: AB phase pulse (4x) (Quadrature Input)
- 1: Clockwise (CW) + Counterclockwise(CCW) pulse
- 2: Pulse + Direction
- 3: Other settings:

B: Input pulse filter

This setting is used to suppress or reduce the chatter caused by the noise, etc. However, if the instant input pulse filter frequency is over high, the frequency that exceeds the setting value will be regarded as noise and filtered.

B	Low Filter	Setting Value	High Filter
0	1.66Mpps	0	6.66Mpps
1	416Kpps	1	1.66Mpps
2	208Kpps	2	833Kpps
3	104Kpps	3	416Kpps
4	No Filter Function	4	No Filter Function

C: Input polarity



Pulse specification		Max. input pulse frequency	Min. time width					
			T1	T2	T3	T4	T5	T6
High-speed pulse	Line receiver	4Mpps	62.5ns	125ns	250ns	200ns	125ns	125ns
Low-speed pulse	Line driver	500Kpps	0.5 μs	1 μs	2 μs	2 μs	1 μs	1 μs
	Open collector	200Kpps	1.25 μs	2.5 μs	5 μs	5 μs	2.5 μs	2.5 μs

Pulse specification		Max. input pulse frequency	Voltage specification	Forward specification
High-speed pulse	Line receiver	4Mpps	5V	< 25mA
Low-speed pulse	Line driver	500Kpps	2.8V ~ 3.7V	< 25mA
	Open collector	200Kpps	24V (Max.)	< 25mA

D: Source of pulse command

Setting value	Input pulse interface	Remark
0	Open collector for low-speed pulse	CN1 Terminal Identification: PULSE, SIGN
1	Line driver for high-speed pulse	CN1 Terminal Identification: PULSE_D, SIGN_D

P1 - 01	CTL	Control Mode and Output Direction	Address: 0102H, 0103H
----------------	------------	--	------------------------------

Default: 0

Related Section: Section 6.1, Table 8.A

Applicable Control Mode: ALL

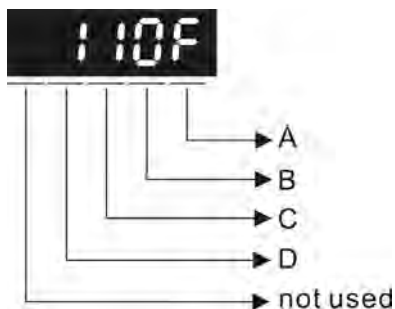
Unit: pulse (P mode), r/min (S mode), N-m (T mode)

Range: 00 ~ 110F

Data Size: 16-bit

Display Format: Hexadecimal

Settings:



A: Control mode settings

	PT	PR	S	T	Sz	Tz
Single Mode						
00	▲					
01		▲				
02			▲			
03				▲		
04					▲	
05						▲
Multiple Mode						
0E	▲	▲	▲			
0F	▲	▲		▲		

	PT	PR	S	T	Sz	Tz
Dual Mode						
06	▲		▲			
07	▲			▲		
08		▲	▲			
09		▲		▲		
0A			▲	▲		
0B	CANopen Mode					
0C	Reserved					
0D	▲	▲				

PT: Position control mode. The command is from external pulse or analog voltage (external analog voltage will be available soon).

PR: Position control mode. The command is from internal signal. Execution of 64 positions is via DI signals (POS0 ~ POS5). A variety of homing control is also provided.

S: Speed control mode. The command is from external signal or internal signal. Execution of the command selection is via DI signals, SPD0 and SPD1.

T: Torque control mode. The command is from external signal or internal signal. Execution of the command selection is via DI signals, TCM0 and TCM1.

Sz: Zero speed / internal speed command

Tz: Zero torque / internal torque command

Dual Mode: Control of the mode selection is via DI signals. For example, either PT or S control mode can be selected via DI signal, S-P (see Table 8.A).

Multiple Mode: Control of the mode selection is via DI signals. For example, either PT or PR or S control mode can be selected via DI signals, S-P and PT-PR (see Table 8.A).

B: Torque output direction settings

Direction	0	1
Forward		
Reverse		

C: Discrete I/O Setting

- 1: When switching to different mode, digital inputs/outputs (P2-10 ~ P2-22) can be reset to be the default value of the mode you switch to.
- 0: When switching to different mode, the setting value of digital inputs/outputs (P2-10 ~ P2-22) will remain the same and will not be changed.

P1 - 02▲	PSTL	Speed and Torque Limit	Address: 0104H, 0105H
-----------------	-------------	-------------------------------	------------------------------

Default: 00

Related Section: Section 6.6, Table 8.A

Applicable Control Mode: ALL

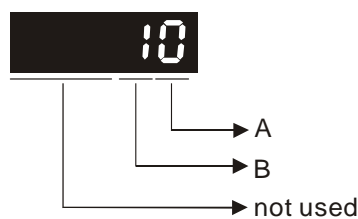
Unit: N/A

Range: 00 ~ 11

Data Size: 16-bit

Display Format: Hexadecimal

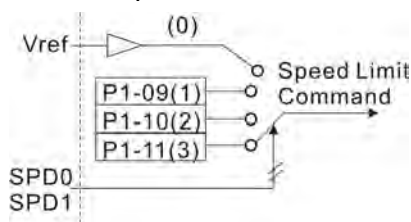
Settings:



A: Disable or Enable speed limit function

0: Disable speed limit function

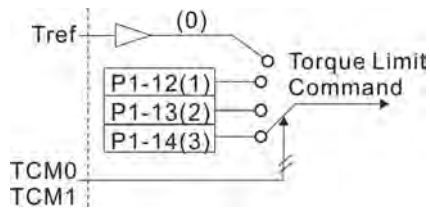
1: Enable speed limit function (It is available in torque mode)



B: Disable or Enable torque limit function

0: Disable torque limit function

1: Enable torque limit function (It is available in position and speed mode)



This parameter is used to determine that the speed and torque limit functions are enabled or disabled. If P1-02 is set to 11, it indicates that the speed and torque limit functions are enabled always. The users can also use DI signals, SPDLM and TRQLM to enable the speed and torque limit functions. Please note that DI signals, SPD0, SPD1, TCM0, and TCM1 are used to select the command source of the speed and torque limit.

P1 - 03

AOUT	Pulse Output Polarity Setting	Address: 0106H, 0107H
------	-------------------------------	-----------------------

Default: 0

Related Section:

Applicable Control Mode: ALL

Section 3.3.3

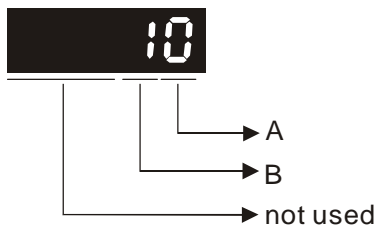
Unit: N/A

Range: 0 ~ 13

Data Size: 16-bit

Display Format: Hexadecimal

Settings:



This parameter is used to determine the polarity of analog monitor outputs and position pulse outputs. The analog monitor outputs can be configured with different polarity individually, but the position pulse outputs have to be each with the same polarity.

A: Analog monitor outputs polarity

0: MON1(+), MON2(+)

1: MON1(+), MON2(-)

2: MON1(-), MON2(+)

3: MON1(-), MON2(-)

B: Position pulse outputs polarity

0: Forward output

1: Reverse output

ASDA-A2**Chapter 8 Servo Parameters**

P1 - 04	MON1	Analog Monitor Output Proportion 1 (CH1)	Address: 0108H, 0109H
Default: 100		Related Section:	
Applicable Control Mode: ALL		Section 6.4.4	
Unit: % (full scale)			
Range: 0 ~ 100			
Data Size: 16-bit			
Display Format: Decimal			
P1 - 05	MON2	Analog Monitor Output Proportion 2 (CH2)	Address: 010AH, 010BH
Default: 100		Related Section:	
Applicable Control Mode: ALL		Section 6.4.4	
Unit: % (full scale)			
Range: 0 ~ 100			
Data Size: 16-bit			
Display Format: Decimal			
P1 - 06	SFLT	Accel / Decel Smooth Constant of Analog Speed Command (Low-pass Filter)	Address: 010CH, 010DH
Default: 0		Related Section:	
Applicable Control Mode: S		Section 6.3.3	
Unit: msec			
Range: 0 ~ 1000 (0: Disabled)			
Data Size: 16-bit			
Display Format: Decimal			
P1 - 07	TFLT	Smooth Constant of Analog Torque Command (Low-pass Filter)	Address: 010EH, 010FH
Default: 0		Related Section:	
Applicable Control Mode: T		Section 6.4.3	
Unit: msec			
Range: 0 ~ 1000 (0: Disabled)			
Data Size: 16-bit			
Display Format: Decimal			

Chapter 8 Servo Parameters

ASDA-A2

P1 - 08	PFLT	Smooth Constant of Position Command (Low-pass Filter)	Address: 0110H, 0111H
----------------	-------------	--	------------------------------

Default: 0

Related Section:

Applicable Control Mode: PT/PR

Section 6.2.6

Unit: 10msec

Range: 0 ~ 1000 (0: Disabled)

Data Size: 16-bit

Display Format: Decimal

P1 - 09	SP1	1st Speed Command or Limit	Address: 0112H, 0113H
----------------	------------	-----------------------------------	------------------------------

Default: 1000

Related Section:

Applicable Control Mode: S, T

Section 6.3.1

Unit: 0.1 r/min

Range: -60000 ~ +60000

Data Size: 32-bit

Display Format: Decimal

Settings:

1st Speed Command

In Speed mode, this parameter is used to set speed 1 of internal speed command.

1st Speed Limit

In Torque mode, this parameter is used to set speed limit 1 of internal speed command.

P1 - 10	SP2	2nd Speed Command or Limit	Address: 0114H, 0115H
----------------	------------	-----------------------------------	------------------------------

Default: 2000

Related Section:

Applicable Control Mode: S, T

Section 6.3.1

Unit: 0.1 r/min

Range: -60000 ~ +60000

Data Size: 32-bit

Display Format: Decimal

Settings:

2nd Speed Command

In Speed mode, this parameter is used to set speed 2 of internal speed command.

2nd Speed Limit

In Torque mode, this parameter is used to set speed limit 2 of internal speed command.

P1 - 11	SP3	3rd Speed Command or Limit	Address: 0116H, 0117H
----------------	------------	-----------------------------------	------------------------------

Default: 3000

Related Section:

Applicable Control Mode: S, T

Section 6.3.1

Unit: 0.1 r/min

Range: -60000 ~ +60000

Data Size: 32-bit

Display Format: Decimal

Settings:

3rd Speed Command

In Speed mode, this parameter is used to set speed 3 of internal speed command.

3rd Speed Limit

In Torque mode, this parameter is used to set speed limit 3 of internal speed command.

P1 - 12	TQ1	1st Torque Command or Limit	Address: 0118H, 0119H
----------------	------------	------------------------------------	------------------------------

Default: 100

Related Section:

Applicable Control Mode: T, P&S

Section 6.4.1

Unit: %

Range: -300 ~ +300

Data Size: 16-bit

Display Format: Decimal

Settings:

1st Torque Command

In Torque mode, this parameter is used to set torque 1 of internal torque command.

1st Torque Limit

In Position and Speed mode, this parameter is used to set torque limit 1 of internal torque command.

Digital output signal TQL is activated when the drive has detected that the motor has reached the torques limits set by either the parameters P1-12 ~ P1-14 or via an external analog voltage.

Chapter 8 Servo Parameters

ASDA-A2

P1 - 13	TQ2	2nd Torque Command or Limit	Address: 011AH, 011BH
----------------	------------	------------------------------------	------------------------------

Default: 100

Related Section:

Applicable Control Mode: T, P&S

Section 6.4.1

Unit: %

Range: -300 ~ +300

Data Size: 16-bit

Display Format: Decimal

Settings:

2nd Torque Command

In Torque mode, this parameter is used to set torque 2 of internal torque command.

2nd Torque Limit

In Position and Speed mode, this parameter is used to set torque limit 2 of internal torque command.

Digital output signal TQL is activated when the drive has detected that the motor has reached the torques limits set by either the parameters P1-12 ~ P1-14 of via an external analog voltage.

P1 - 14	TQ3	3rd Torque Command or Limit	Address: 011CH, 011DH
----------------	------------	------------------------------------	------------------------------

Default: 100

Related Section:

Applicable Control Mode: T, P&S

Section 6.4.1

Unit: %

Range: -300 ~ +300

Data Size: 16-bit

Display Format: Decimal

Settings:

3rd Speed Command

In Torque mode, this parameter is used to set torque 3 of internal torque command.

3rd Speed Limit

In Position and Speed mode, this parameter is used to set torque limit 3 of internal torque command.

Digital output signal TQL is activated when the drive has detected that the motor has reached the torques limits set by either the parameters P1-12 ~ P1-14 of via an external analog voltage.

P1 - 15	Reserved (Do Not Use)
P1 - 16	Reserved (Do Not Use)
P1 - 17	Reserved (Do Not Use)

P1 - 18	Reserved (Do Not Use)
P1 - 19	Reserved (Do Not Use)
P1 - 20	Reserved (Do Not Use)
P1 - 21	Reserved (Do Not Use)
P1 - 22	Reserved (Do Not Use)
P1 - 23	Reserved (Do Not Use)
P1 - 24	Reserved (Do Not Use)

P1 - 25	VSF1	Low-frequency Vibration Suppression (1)	Address: 0132H, 0133H
----------------	-------------	--	------------------------------

Default: 100.0

Applicable Control Mode: PT/PR

Unit: Hz

Range: 1.0 ~ 100.0

Data Size: 16-bit

Display Format: Decimal

Settings:

This parameter is used to set the first group of the low-frequency of mechanical system. It can be used to suppress the low-frequency vibration of mechanical system. If P1-26 is set to 0, this parameter is disabled.

Related Section:

Section 6.2.9

P1 - 26	VSG1	Low-frequency Vibration Suppression Gain (1)	Address: 0134H, 0135H
----------------	-------------	---	------------------------------

Default: 0

Applicable Control Mode: PT/PR

Unit: -

Range: 0 ~ 9 (0: Disable the function of P1-25)

Data Size: 16-bit

Display Format: Decimal

Settings:

This parameter is used to set the vibration suppression gain for P1-25. When the setting value is higher, the position response is quicker. However, if the setting value is over high, it may addect the normal operation of servo motor. It is recommended to set P1-26 as 1.

Related Section:

Section 6.2.9

Chapter 8 Servo Parameters

ASDA-A2

P1 - 27	VSF2	Low-frequency Vibration Suppression (2)	Address: 0136H, 0137H
Default: 100.0		Related Section:	
Applicable Control Mode: PT/PR		Section 6.2.9	
Unit: Hz			
Range: 1.0 ~ 100.0			
Data Size: 16-bit			
Display Format: Decimal			
Settings:			
This parameter is used to set the second group of the low-frequency of mechanical system. It can be used to suppress the low-frequency vibration of mechanical system. If P1-28 is set to 0, this parameter is disabled.			

P1 - 28	VSG2	Low-frequency Vibration Suppression Gain (2)	Address: 0138H, 0139H
Default: 0		Related Section:	
Applicable Control Mode: PT/PR		Section 6.2.9	
Unit: -			
Range: 0 ~ 9 (0: Disable the function of P1-27)			
Data Size: 16-bit			
Display Format: Decimal			
Settings:			
This parameter is used to set the vibration suppression gain for P1-27. When the setting value is higher, the position response is quicker. However, if the setting value is over high, it may addect the normal operation of servo motor. It is recommended to set P1-28 as 1.			

P1 - 29	AVSM	Auto Low-frequency Vibration Suppression Mode Selection	Address: 013AH, 013BH
Default: 0		Related Section:	
Applicable Control Mode: PT/PR		Section 6.2.9	
Unit: -			
Range: 0 ~ 1			
Data Size: 16-bit			
Display Format: Decimal			
Settings:			
0: Normal mode (Disable Auto Low-frequency Vibration Suppression Mode).			
1: Auto mode (Enable Auto Low-frequency Vibration Suppression Mode).			

Explanation:

If P1-29 is set to 0, the setting of low-frequency vibration suppression is fixed and will not change automatically.

If P1-29 is set to 1, when there is no low-frequency vibration or the low-frequency vibration becomes less and stable, the system will set P1-29 to 0, save the measured low-frequency value automatically and memorize it in P1-25.

P1 - 30	VCL	Low-frequency Vibration Detection Level	Address: 013CH, 013DH
----------------	------------	--	------------------------------

Default: 500

Related Section:

Applicable Control Mode: PT/PR

Section 6.2.9

Unit: pulse

Range: 1 ~ 8000

Data Size: 16-bit

Display Format: Decimal

Settings:

When P1-29 is set to 1, the system will find this detection level automatically. If the setting value of P1-30 is too low, the detection of frequency will become sensitive and result in erroneous measurement. If the setting value of P1-30 is too high, although the probability of erroneous measurement will decrease, the frequency will become difficult to be found especially when the vibration of mechanical system is less.

P1 - 31	Reserved (Do Not Use)		
----------------	------------------------------	--	--

P1 - 32	LSTP	Motor Stop Mode Selection	Address: 0140H, 0141H
----------------	-------------	----------------------------------	------------------------------

Default: 0

Related Section: N/A

Applicable Control Mode: ALL

Unit: N/A

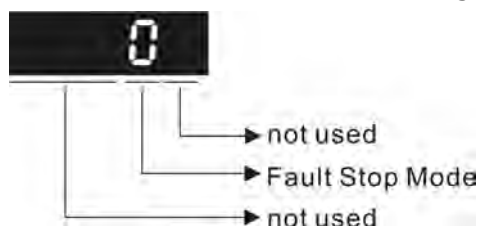
Range: 0 ~ 20

Data Size: 16-bit

Display Format: Hexadecimal

Settings:

This parameter is used to select servo motor stop mode when Servo Off or a fault (servo alarm, includes EMGS (Emergency stop)) occurs.



Fault Stop Mode

0: Use dynamic brake

1: Allow servo motor to coast to stop

2: Use dynamic brake first, after the motor speed is below than P1-38, allow servo motor to coast to stop

When the fault NL(CWL) or PL(CCWL) occurs, please refer to the settings of parameter P5-03 to determine the deceleration time. If the deceleration time is set to 1msec, the motor will stop instantly.

P1 - 33**Reserved (Do Not Use)****P1 - 34****TACC Acceleration Time****Address: 0144H, 0145H**

Default: 200

Related Section:

Applicable Control Mode: S

Section 6.3.3,

Unit: msec

Range: 1 ~ 65500

Data Size: 16-bit

Display Format: Decimal

Settings:

This parameter is used to determine the acceleration time to accelerate from 0 to its rated motor speed. The functions of parameters P1-34, P1-35 and P1-36 are each individual. When P1-36 is set to 0 (Disabled), the settings of P1-34, P1-35 are still effective. It indicates that the parameters P1-34 and P1-35 will not become disabled even when P1-36 is disabled.

Please note:

1. When the source of speed command is analog command, the maximum setting value of P1-36 is set to 0, the acceleration and deceleration function will be disabled.
2. When the source of speed command is analog command, the maximum setting value of P1-34 is limited to 20000 automatically.

P1 - 35**TDEC Deceleration Time****Address: 0146H, 0147H**

Default: 200

Related Section:

Applicable Control Mode: S

Section 6.3.3,

Unit: msec

Range: 1 ~ 65500

Data Size: 16-bit

Display Format: Decimal

Settings:

This parameter is used to determine the acceleration time to accelerate from 0 to its rated motor speed. The functions of parameters P1-34, P1-35 and P1-36 are each individual. When P1-36 is set to 0 (Disabled), the settings of P1-34, P1-35 are still effective. It indicates that the parameters P1-34 and P1-35 will not become disabled even when P1-36 is disabled.

Please note:

1. When the source of speed command is analog command, the maximum setting value of P1-36 is set to 0, the acceleration and deceleration function will be disabled.
2. When the source of speed command is analog command, the maximum setting value of P1-35 is limited to 20000 automatically.

P1 - 36	TSL	Accel /Decel S-curve	Address: 0148H, 0149H
----------------	------------	-----------------------------	------------------------------

Default: 0

Unit: msec

Applicable Control Mode: S, PR

Unit: msec

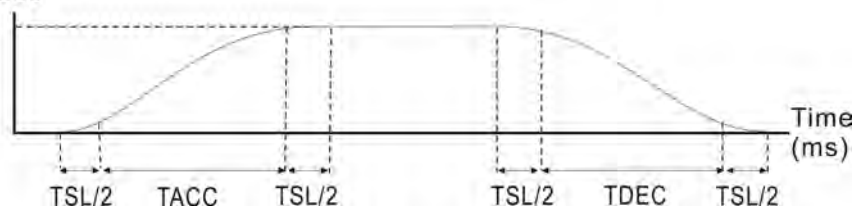
Range: 0 ~ 65500 (0: Disabled)

Data Size: 16-bit

Display Format: Decimal

Settings:

This parameter is used to make the motor run more smoothly when startup and windup. Using this parameter can improve the motor running stability.

Speed

TACC: P1-34, Acceleration time

TDEC: P1-35, Deceleration time

TSL: P1-36, Accel /Decel S-curve

Total acceleration time = TACC + TSL

Total deceleration time = TDEC + TSL

The functions of parameters P1-34, P1-35 and P1-36 are each individual. When P1-36 is set to 0 (Disabled), the settings of P1-34, P1-35 are still effective. It indicates that the parameters P1-34 and P1-35 will not become disabled even when P1-36 is disabled.

Please note:

1. When the source of speed command is analog command, the maximum setting value of P1-36 is set to 0, the acceleration and deceleration function will be disabled.

2. When the source of speed command is analog command, the maximum setting value of P1-36 is limited to 10000 automatically.

P1 - 37	GDR	Ratio of Load Inertia to Servo Motor Inertia	Address: 014AH, 014BH
----------------	------------	---	------------------------------

Default: 10

Related Section: N/A

Applicable Control Mode: ALL

Unit: 0.1 times

Range: 0 ~ 2000

Data Size: 16-bit

Display Format: Decimal

Settings:

Ratio of load inertia to servo motor inertia (for Rotation Motor): (J_load / J_motor)

J_load: Total equivalent moment of inertia of external mechanical load

J_motor: Moment of inertia of servo motor

Ratio of load weight to servo motor weight (for Linear Motor): (M_load / M_motor)(not available now but will be available soon)

M_load: Total equivalent weight of external mechanical load

M_motor: Weight of servo motor

P1 - 38	ZSPD	Zero Speed Range Setting	Address: 014CH, 014DH
----------------	-------------	---------------------------------	------------------------------

Default: 100

Related Section: Table 8.A

Applicable Control Mode: ALL

Unit: 0.1 r/min

Range: 0 ~ 2000

Data Size: 16-bit

Display Format: Decimal

Settings:

This parameter is used to set output range of zero speed signal (ZSPD) and determine when zero speed signal (ZSPD) becomes activated. ZSPD is activated when the drive senses the motor is equal to or below the Zero Speed Range setting as defined in parameter P1-38.

For Example, at default ZSPD will be activated when the drive detects the motor rotating at speed at or below 100 r/min. ZSPD will remain activated until the motor speed increases above 100 r/min.

P1 - 39	SSPD	Target Motor Speed	Address: 014EH, 014FH
----------------	-------------	---------------------------	------------------------------

Default: 3000

Related Section: Table 8.A

Applicable Control Mode: ALL

Unit: r/min

Range: 0 ~ 5000

Data Size: 16-bit

Display Format: Decimal

Settings:

When target motor speed reaches its preset value, digital output (TSPD) is enabled.

When the forward and reverse speed of servo motor is equal and higher than the setting value, the motor will reach the target motor speed, and then TSPD signal will output.

TSPD is activated once the drive has detected the motor has reached the Target Motor Speed setting as defined in parameter P1-39. TSPD will remain activated until the motor speed drops below the Target Motor Speed.

P1 - 40▲	VCM	Max. Analog Speed Command or Limit	Address: 0150H, 0151H
-----------------	------------	---	------------------------------

Default: rated speed

Related Section:

Applicable Control Mode: S, T

Section 6.3.4

Unit: r/min

Range: 0 ~ 10000

Data Size: 16-bit

Display Format: Decimal

Settings:

In **Speed mode**, this parameter is used to set the maximum analog speed command based on the maximum input voltage (10V).

In **Torque mode**, this parameter is used to set the maximum analog speed limit based on the maximum input voltage (10V).

For example, in speed mode, if P1-40 is set to 3000 and the input voltage is 10V, it indicates that the speed command is 3000 r/min. If P1-40 is set to 3000, but the input voltage is changed to 5V, then the speed command is changed to 1500 r/min.

Speed Command / Limit = Input Voltage Value x Setting value of P1-40 / 10

P1 - 41 ▲	TCM	Max. Analog Torque Command or Limit	Address: 0152H, 0153H
------------------	------------	--	------------------------------

Default: 100

Related Section:

Applicable Control Mode: ALL

Section 6.4.4

Unit: %

Range: 0 ~ 1000

Data Size: 16-bit

Display Format: Decimal

Settings:

In **Torque mode**, this parameter is used to set the maximum analog torque command based on the maximum input voltage (10V).

In **Position (PT, PR)** and **Speed mode**, this parameter is used to set the maximum analog torque limit based on the maximum input voltage (10V).

For example, in torque mode, if P1-41 is set to 100 and the input voltage is 10V, it indicates that the torque command is 100% rated torque. If P1-41 is set to 100, but the input voltage is changed to 5V, then the torque command is changed to 50% rated torque.

$\text{Torque Command / Limit} = \text{Input Voltage Value} \times \text{Setting value of P1-41} / 10$

P1 - 42	MBT1	On Delay Time of Electromagnetic Brake	Address: 0154H, 0155H
----------------	-------------	---	------------------------------

Default: 0

Related Section:

Applicable Control Mode: ALL

Section 6.5.5, Table 8.B

Unit: msec

Range: 0 ~ 1000

Data Size: 16-bit

Display Format: Decimal

Settings:

Used to set the period of time between when the servo drive is On (Servo On) and when electromagnetic brake output signal (BRKR) is activated.

P1 - 43	MBT2	OFF Delay Time of Electromagnetic Brake	Address: 0156H, 0157H
----------------	-------------	--	------------------------------

Default: 0

Related Section:

Applicable Control Mode: ALL

Section 6.5.5, Table 8.B

Unit: msec

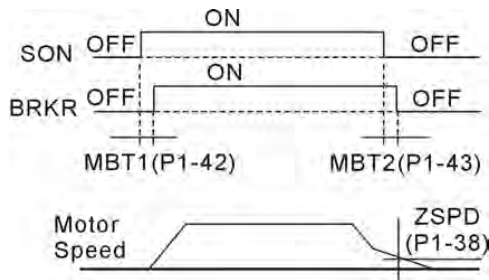
Range: -1000 ~ +1000

Data Size: 16-bit

Display Format: Decimal

Settings:

Used to set the period of time between when the servo drive is Off (Servo Off) and when electromagnetic brake output signal (BRKR) is inactivated.

**Please note:**

1. When servo is commanded off and the off delay time set by P1-43 has not elapsed, if the motor speed is lower than the setting value of P1-38, the electromagnetic brake will be engaged regardless of the off delay time set by P1-43.
2. When servo is commanded off and the off delay time set by P1-43 has elapsed, if the motor speed is higher than the setting value of P1-38, electromagnetic brake will be engaged regardless of the current motor speed.
3. When the servo drive is disabled (Servo Off) due to a fault (except AL022) or by EMGS (Emergency stop) being activated, if the off delay time set by P1-43 is a negative value, it will not affect the operation of the motor. A negative value of the off delay time is equivalent to one with a zero value.

P1 - 44 ▲	GR1	Electronic Gear Ratio (1st Numerator) (N1)	Address: 0158H, 0159H
------------------	------------	---	------------------------------

Default: 128

Related Section:

Applicable Control Mode: PT, PR

Section 6.2.5

Unit: pulse

Range: 1 ~ (2²⁹-1)

Data Size: 32-bit

Display Format: Decimal

Settings:

This parameter is used to set the numerator of the electronic gear ratio. The denominator of the electronic gear ratio is set by P1-45. P2-60 ~ P2-62 are used to set the additional numerators.

Please note:

1. In PT mode, the setting value of P1-44 can be changed only when the servo drive is enabled (Servo On).
2. In PR mode, the setting value of P1-44 can be changed only when the servo drive is disabled (Servo Off).

P1 - 45▲	GR2	Electronic Gear Ratio (Denominator) (M)	Address: 015AH, 015BH
-----------------	------------	--	------------------------------

Default: 10

Related Section:

Applicable Control Mode: PT, PR

Section 6.3.6

Unit: pulse

Range: 1 ~ (2³¹-1)

Data Size: 32-bit

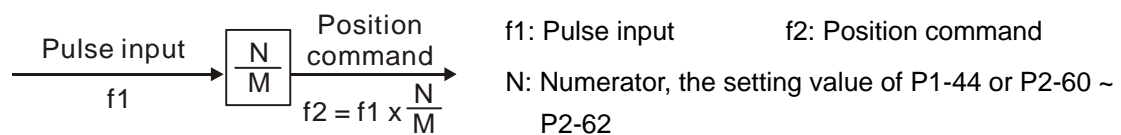
Display Format: Decimal

Settings:

This parameter is used to set the denominator of the electronic gear ratio. The numerator of the electronic gear ratio is set by P1-44. P2-60 ~ P2-62 are used to set the additional numerators.

As the wrong setting may cause motor to run chaotically (out of control) and it may lead to personnel injury, therefore, ensure to observe the following rule when setting P1-44, P1-45.

The electronic gear ratio setting (Please also see P1-44, P2-60 ~ P2-62):



M: Denominator, the setting value of P1-45

The electronic gear ratio setting range must be within: 1/50 < N/M < 25600.

Please note:

1. In PT and PR mode, the setting value of P1-45 can not be changed when the servo drive is enabled (Servo On).

P1 - 46▲	GR3	Encoder Output Pulse Number	Address: 015CH, 015DH
-----------------	------------	------------------------------------	------------------------------

Default: 2500

Related Section: N/A

Applicable Control Mode: ALL

Unit: pulse

Range: 20 ~ 320000

Data Size: 32-bit

Display Format: Decimal

Settings:

This parameter is used to set the pulse numbers of encoder outputs per motor revolution.

Please note:

When the following conditions occur, the output frequency for pulse output may exceed the specification and cause that the servo drive fault AL018 (Encoder Output Error) is activated.

Condition 1: Encoder error.

Condition 2: Motor speed is above the value set by parameter P1-76.

Condition 3: $\frac{\text{Motor Speed}}{60} \times P1-46 \times 4 > 19.8 \times 10^6$

P1 - 47	SPOK	Speed Reached Output Range	Address: 015EH, 015FH
----------------	-------------	-----------------------------------	------------------------------

Default: 10

Related Section: N/A

Applicable Control Mode: S, Sz

Unit: r/min

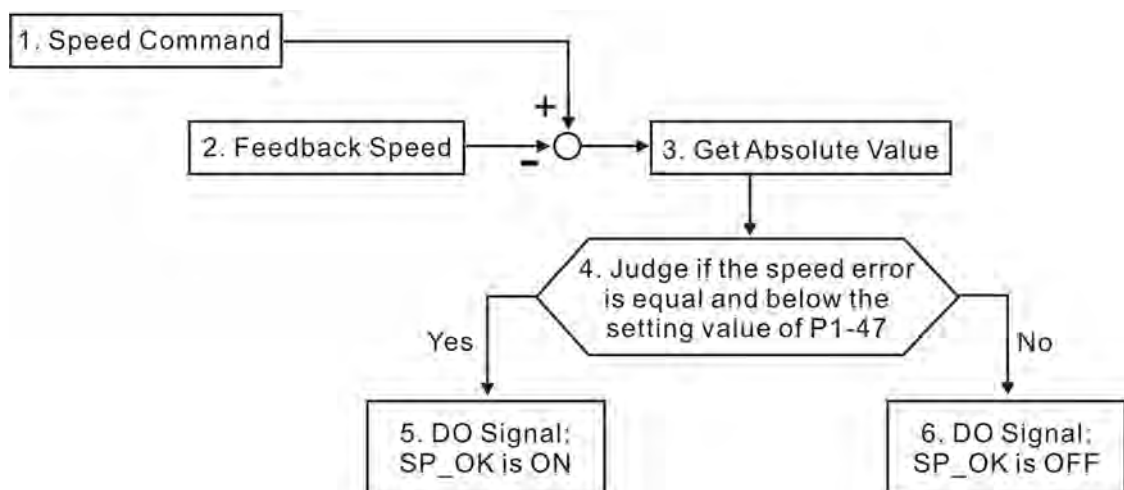
Range: 0 ~ 300

Data Size: 32-bit

Display Format: Decimal

Settings:

This parameter is used to set the speed reached output range. The DO signal, SP_OK will be activated when the speed error is equal and below the setting value of P1-47.



1. Speed Command: It is the speed command input by the users (no Accel/Decel), not the frond-end command of speed control loop. The source of this command includes analog voltage and registers.

2. Feedback Speed: It is the actual motor speed which is filtered.

3. Get Absolute Value

4. Judge if the speed error is equal and below the setting value of P1-47: When P1-47 is set to 0, this digital output will be always off.

5. ON or OFF: When the speed error is equal and below the setting value of P1-47, SP_OK will be ON; otherwise, SP_OK will be OFF.

P1 - 48

MCOK

Motion Control Completed Output Selection

Address: 0160H, 0161H

Default: 0x0000

Related Section: N/A

Applicable Control Mode: PR

Unit: N/A

Range: 0x0000 ~ 0x0011

Data Size: 16-bit

Display Format: Hexadecimal

Settings: (for firmware version V1.003 sub08 and later models only)

This parameter is used to determine the operation after digital output signal, MC_OK (DO code is 0x17) is activated.

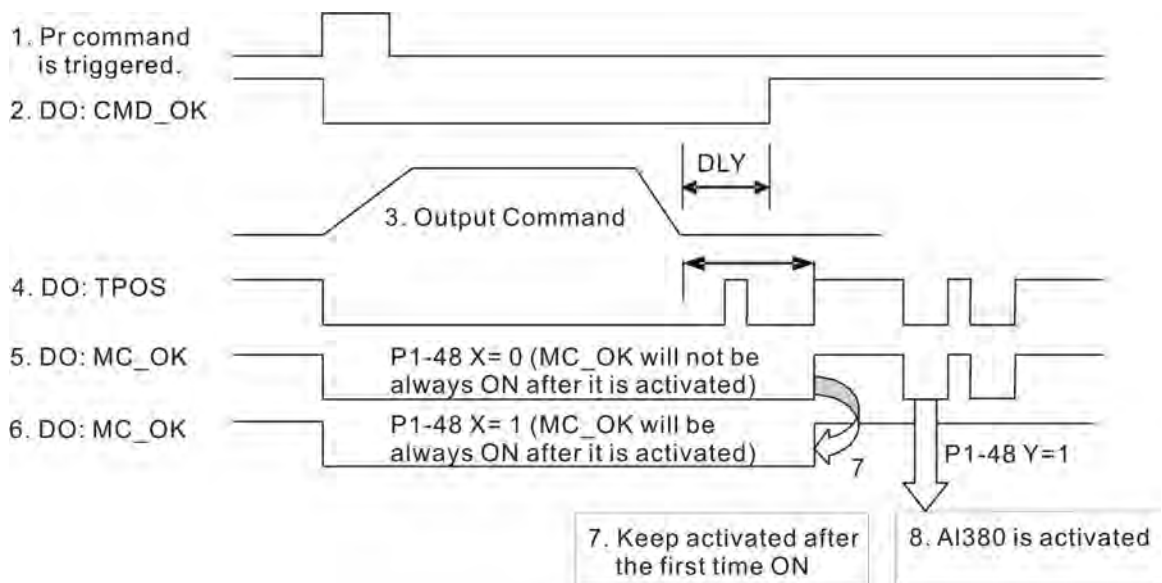
Display	0	0	Y	X
Range	-	-	0 ~ 1	0 ~ 1

X=0: MC_OK will not be always ON after it is activated.

X=1: MC_OK will be always ON after it is activated.

Y=0: Servo fault AL380 will not be activated.

Y=1: Servo fault AL380 will be activated.



1. PR command is triggered: It indicates that the new PR command becomes effective. When the signal 3 starts to output the command, the signals 2, 4 and 5 will be clear simultaneously.

2. CMD_OK: CMD_OK is used to detect if the internal position command, signal 3 has been completed. DLY delay time can also be set.

3. Output Command: Output the internal position command according to desired acceleration and deceleration.

4. TPOS: It is activated when the position error is equal and below the setting value of P1-54.

- 5. MC_OK (P1-48 X=0): It is activated when the position command has output and the positioning is completed also, i.e. CMD_OK and TPOS are both ON. However, once TPOS becomes OFF, it will become OFF as well.
- 6 MC_OK (P1-48 X=1): It is activated when the position command has output and the positioning is completed also, i.e. CMD_OK and TPOS are both ON. However, when TPOS becomes OFF, it will not become OFF. It will be always ON
- 7. The signal 5 and signal 6 cannot be selected simetaneously. This function is determined by X setting of P1-48.
- 8. Position deviation alarm (AL380): After signal 7 occurs, if signal 4 or 5 becomes off, it indicates a position deviation alarm is detected and AL380 can be activated to provide a alarm signal. This function is determined by Y setting of P1-48.

P1 - 49	Reserved (Do Not Use)
P1 - 50	Reserved (Do Not Use)
P1 - 51	Reserved (Do Not Use)

P1 - 52	RES1	Regenerative Resistor Value	Address: 0168H, 0169H
----------------	-------------	------------------------------------	------------------------------

Default: -

Related Section:

Applicable Control Mode: ALL

Section 6.6.3

Unit: Ohm

Range: 10 ~ 750

Data Size: 16-bit

Display Format: Decimal

Settings:

This parameter is used to set the resistance of the applicable regenerative resistor.

Model	Default
For 1.5kW and below models	40 Ω
For 2kW to 4.5kW models	20 Ω
For 5.5kW	15 Ω

P1 - 53	RES2	Regenerative Resistor Capacity	Address: 016AH, 016BH
----------------	-------------	---------------------------------------	------------------------------

Default: -

Related Section:

Applicable Control Mode: ALL

Section 6.6.3

Unit: Watt

Range: 30 ~ 3000

Data Size: 16-bit

Display Format: Decimal

Settings:

This parameter is used to set the capacity of the applicable regenerative resistor.

Model	Default
For 1.5kW and below models	60W
For 2kW to 4.5kW models	100W
5.5kW	0W

P1 - 54

PER	Positioning Completed Width	Address: 016CH, 016DH
-----	-----------------------------	-----------------------

Default: 12800

Related Section: Table 8.A

Applicable Control Mode: PT , PR

Unit: pulse

Range: 0 ~ 1280000

Data Size: 32-bit

Display Format: Decimal

Settings:

In PT mode, when the error pulse numbers is less than the setting value of parameter P1-54, TPOS (At positioning completed signal) will be activated.

In PR mode, when the difference in pulse number between the target position and the actual position is less than the setting value of parameter P1-54, TPOS (At positioning completed signal) will be activated.

P1 - 55

MSPD	Maximum Speed Limit	Address: 016EH, 016FH
------	---------------------	-----------------------

Default: rated speed

Related Section: N/A

Applicable Control Mode: ALL

Unit: r/min

Range: 0 ~ Max. speed

Data Size: 16-bit

Display Format: Decimal

Settings:

This parameter is used to set maximum motor speed. The default setting is rated speed.

P1 - 56	OVW	Output Overload Warning Time	Address: 0170H, 0171H
----------------	------------	-------------------------------------	------------------------------

Default: 120

Related Section: N/A

Applicable Control Mode: ALL

Unit: %

Range: 0 ~ 120

Data Size: 16-bit

Display Format: Decimal

Settings:

This parameter is used to set output overload time. If the setting value of parameter P1-56 is set to 0 ~ 100, the function of parameter P1-56 is enabled. When the motor has reached the output overload time set by parameter P1-56, the motor will send a warning to the drive. After the drive has detected the warning, the DO signal OLV will be activated. If the setting value of parameter P1-56 exceeds 100, the function of parameter P1-56 is disabled.

t_{OL} = Permissible Time for Overload x the setting value of parameter P1-56

When overload accumulated time (continuously overload time) exceeds the value of **t_{OL}**, the overload warning signal will output, i.e. DO signal, OLV will be ON. However, if the accumulated overload time (continuous overload time) exceeds the permissible time for overload, the overload alarm (AL006) will occur.

For example:

If the setting value of parameter P1-56 (Output Overload Warning Time) is 60%, when the permissible time for overload exceeds 8 seconds at 200% rated output, the overload fault (AL006) will be detected and shown on the LED display.

At this time, **t_{OL}** = 8 x 60% = 4.8 seconds

Result:

When the drive output is at 200% rated output and the drive is continuously overloaded for 4.8 seconds, the overload warning signal will be ON, i.e. DO signal OLV will be activated. If the drive is continuously overloaded for 8 seconds, the overload alarm will be detected and shown on the LED display (AL006). Then, Servo Fault signal will be ON (DO signal ALRM will be activated).

P1 - 57	CRSHA	Motor Protection Percentage	Address: 0172H, 0173H
----------------	--------------	------------------------------------	------------------------------

Default: 0

Related Section: -

Applicable Control Mode: ALL

Unit: %

Range: 0 ~ 300

Data Size: 16-bit

Display Format: Decimal

Settings:

This parameter is used to protect the motor in case the motor touches the mechanical equipment. If P1-57 is set to 0, the function of P1-57 is disabled. The function of P1-57 is enabled when the setting value of P1-57 is set to 1 or more. The fault AL030 will be activated when the setting value of P1-57 is reached after a period of time set by P1-58.

P1 - 58	CRSHT	Motor Protection Time	Address: 0174H, 0175H
----------------	--------------	------------------------------	------------------------------

Default: 1

Related Section: P1-57

Applicable Control Mode: ALL

Unit: msec

Range: 0 ~ 1000

Data Size: 16-bit

Display Format: Decimal

Settings:

This parameter is used to protect the motor in case the motor touches the mechanical equipment. The fault AL030 will be activated when the setting value of P1-57 is reached after a period of time set by P1-58.

Please note that this function is applicable for non-contact applications, such as electric discharge machines only (P1-37 must be set correctly).

P1 - 59	MFLT	Analog Speed Linear Filter (Moving Filter)	Address: 0176H, 0177H
----------------	-------------	---	------------------------------

Default: 0

Related Section: N/A

Applicable Control Mode: S

Unit: 0.1 msec

Range: 0 ~ 40 (0: Disabled)

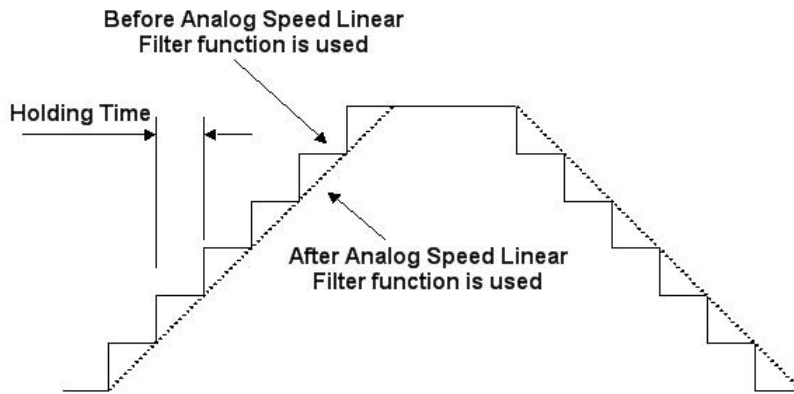
Data Size: 16-bit

Display Format: Decimal

Settings:

This parameter is used to eliminate the noise generated during the operation when the host (external) controller sends the step analog voltage speed command. The parameter P1-06 is Low-pass Filter and parameter P1-59 is Moving Filter. The differences are that Low-pass Filter is usually used to smooth the end of the command but Moving Filter can be used to smooth the start and the end of step analog voltage speed command. Using Moving Filter can facilitate the smooth operation of the motor very effectively.

Therefore, it is recommended to use P1-06 Low-pass Filter when the speed command from the external controller is applied for position control loop. If the command is for speed control only, using Moving Filter P1-59 can achieve better (smooth) performance.



P1 - 60	Reserved (Do Not Use)	
P1 - 61	Reserved (Do Not Use)	

P1 - 62	FRCL	Friction Compensation Percentage	Address: 017CH, 017DH
----------------	-------------	---	------------------------------

Default: 0

Related Section: N/A

Applicable Control Mode: PT, PR, S

Unit: %

Range: 0 ~ 100

Data Size: 16-bit

Display Format: Decimal

Settings:

This parameter is used to set the torque percentage for friction compensation. If P1-62 is set to 0, the function of P1-62 is disabled. The function of P1-62 is enabled when the setting value of P1-62 is set to 1 or more.

P1 - 63	FRCT	Friction Compensation Smooth Constant	Address: 017EH, 017FH
----------------	-------------	--	------------------------------

Default: 0

Related Section: N/A

Applicable Control Mode: ALL

Unit: msec

Range: 0 ~ 1000

Data Size: 16-bit

Display Format: Decimal

Settings:

This parameter is used to set the smooth constant of friction compensation.

P1 - 64	Reserved (Do Not Use)	
P1 - 65	Reserved (Do Not Use)	

Chapter 8 Servo Parameters

ASDA-A2

P1 - 66	PCM	Max. Rotation Number of Analog Position Command (will be available soon)	Address: 0184H, 0185H
----------------	------------	---	------------------------------

Default: 30

Related Section: N/A

Applicable Control Mode: PT

Unit: 0.1 rotation

Range: 0 ~ 10000

Data Size: 16-bit

Display Format: Decimal

Settings:

This parameter is used to set the maximum rotation number of analog position command based on the maximum input voltage (10V).

For example, if P1-66 is set to 30 and the input voltage is 10V, it indicates that the position command is +3 rotations. If P1-66 is set to 30, but the input voltage is changed to 5V, then the position command is +1.5 rotations.

Position Command = Input Voltage Value x Setting value of P1-66 / 10

P1 - 67	Reserved (Do Not Use)		
----------------	------------------------------	--	--

P1 - 68	PFLT2	Position Command Moving Filter	Address: 0188H, 0189H
----------------	--------------	---------------------------------------	------------------------------

Default: 4

Related Section: N/A

Applicable Control Mode: PT, PR

Unit: msec

Range: 0 ~ 100

Data Size: 16-bit

Display Format: Decimal

P1 - 69	Reserved (Do Not Use)		
P1 - 70	Reserved (Do Not Use)		
P1 - 71	Reserved (Do Not Use)		

P1 - 72	FRES	Full-closed Loop Resolution	Address: 0190H, 0191H
----------------	-------------	------------------------------------	------------------------------

Default: 5000

Related Section: N/A

Applicable Control Mode: PT, PR

Unit: pulse (PT mode), rev (PR mode)

Range: 200 ~ 80000

Data Size: 32-bit

Display Format: Decimal

Settings:

This parameter is used to set the corresponding AB (Quadrature) phase pulses (4x) for full-closed loop per motor revolution.

P1 - 73	FERR	Full-closed Loop Excessive Position Error Range	Address: 0192H, 0193H
----------------	-------------	--	------------------------------

Default: 30000

Related Section: P2-34

Applicable Control Mode: PT, PR

Unit: pulse (based on full-closed loop)

Range: 1 ~ (2³¹-1)

Data Size: 32-bit

Display Format: Decimal

Settings:

When the position of A/B counter feedbacked by full-closed loop is too far from the position feedbacked by the encoder of the servo motor, it indicates that the encoder connector may loose or there is some problem occurred on connected mechanical system.

P1 - 74▲	FCON	Full-closed Loop Control Function Selection	Address: 0194H, 0195H
-----------------	-------------	--	------------------------------

Default: 0000h

Related Section: P1-46

Applicable Control Mode: PT, PR

Unit: N/A

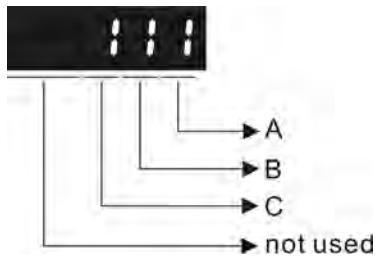
Range: 0000h ~ 0121h

Data Size: 16-bit

Display Format: Hexadecimal

Settings:

This parameter is used to determine the function of full-closed loop control.



A: Full-closed loop function selection

0: Disable full-closed loop function.

1: Enable full-closed loop function.

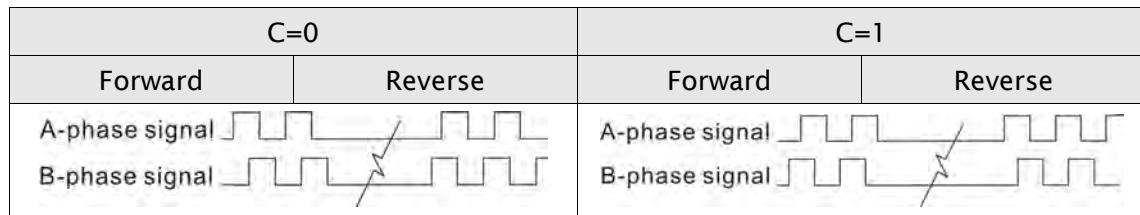
B: Source of OA/OB/OZ outputs

0: The source of OA/OB/OZ outputs is the encoder of the motor.

1: The source of OA/OB/OZ outputs is the encoder of the linear scale full-closed loop.

2: The source of OA/OB/OZ outputs is the pulse command of CN1 (only provided by the firmware DSP V1.016 + CPLD 0.07 and later models.).

C: Polarity setting of linear scale

**P1 - 75**

FELP	Full-closed Loop Low-pass Filter Time Constant	Address: 0196H, 0197H
-------------	---	------------------------------

Default: 100

Related Section: N/A

Applicable Control Mode: PT, PR

Unit: msec

Range: 0 ~ 1000

Data Size: 16-bit

Display Format: Decimal

Settings:

When the stiffness of the mechanical system between full-closed loop and half-closed loop is insufficient, the users can use this parameter to enhance the stability of the mechanical system.

When P1-75 is set to 0, the low-pass filter function is disabled.

The stiffness of the mechanical system \uparrow , the setting value of P1-75 \downarrow .

The stiffness of the mechanical system \downarrow , the setting value of P1-75 \uparrow .

P1 - 76

AMSPD	Max. Rotation Speed of Encoder Output	Address: 0198H, 0199H
--------------	--	------------------------------

Default: 5500

Related Section: P1-46

Applicable Control Mode: ALL

Unit: r/min

Range: 0 ~ 6000 (0: Disabled)

Data Size: 16-bit

Display Format: Decimal

Settings:

This parameter is used to optimize the encoder outputs (OA, OB). When the users set the actual reached maximum motor speed, the servo drive will equalize the encoder outputs automatically. When P1-76 is set to 0, it indicates that equalizing function is not available.

Group 2: P2-xx Extension Parameters

P2 - 00	KPP	Proportional Position Loop Gain	Address: 0200H, 0201H
----------------	------------	--	------------------------------

Default: 35

Related Section:

Applicable Control Mode: PT, PR

Section 6.2.8

Unit: rad/s

Range: 0 ~ 2047

Data Size: 16-bit

Display Format: Decimal

Settings:

This parameter is used to set the position loop gain. It can increase stiffness, expedite position loop response and reduce position error. However, if the setting value is over high, it may generate vibration or noise.

P2 - 01	PPR	Position Loop Gain Switching Rate	Address: 0202H, 0203H
----------------	------------	--	------------------------------

Default: 100

Related Section:

Applicable Control Mode: PT, PR

Section 6.2.8

Unit: %

Range: 10 ~ 500

Data Size: 16-bit

Display Format: Decimal

Settings:

This parameter is used to set the position gain switching rate when the gain switching condition is satisfied. Please refer to P2-27 for gain switching control selection settings and refer to P2-29 for gain switching condition settings.

P2 - 02	PFG	Position Feed Forward Gain	Address: 0204H, 0205H
----------------	------------	-----------------------------------	------------------------------

Default: 50

Related Section:

Applicable Control Mode: PT, PR

Section 6.2.8

Unit: %

Range: 0 ~ 100

Data Size: 16-bit

Display Format: Decimal

Settings:

This parameter is used to set the feed forward gain when executing position control command. When using position smooth command, increase gain can improve position track deviation. When not using position smooth command, decrease gain can improve the resonance condition of mechanical system.

Chapter 8 Servo Parameters**ASDA-A2**

P2 - 03	PFF	Smooth Constant of Position Feed Forward Gain	Address: 0206H, 0207H
----------------	------------	--	------------------------------

Default: 5

Related Section: N/A

Applicable Control Mode: PT, PR

Unit: msec

Range: 2 ~ 100

Data Size: 16-bit

Display Format: Decimal

Settings:

When using position smooth command, increase gain can improve position track deviation. When not using position smooth command, decrease gain can improve the resonance condition of mechanical system.

P2 - 04	KVP	Proportional Speed Loop Gain	Address: 0208H, 0209H
----------------	------------	-------------------------------------	------------------------------

Default: 500

Related Section:

Applicable Control Mode: ALL

Section 6.3.6

Unit: rad/s

Range: 0 ~ 8191

Data Size: 16-bit

Display Format: Decimal

Settings:

This parameter is used to set the speed loop gain. When the value of proportional speed loop gain is increased, it can expedite speed loop response. However, if the setting value is over high, it may generate vibration or noise.

P2 - 05	SPR	Speed Loop Gain Switching Rate	Address: 020AH, 020BH
----------------	------------	---------------------------------------	------------------------------

Default: 100

Related Section: N/A

Applicable Control Mode: ALL

Unit: %

Range: 10 ~ 500

Data Size: 16-bit

Display Format: Decimal

Settings:

This parameter is used to set the speed gain switching rate when the gain switching condition is satisfied. Please refer to P2-27 for gain switching control selection settings and refer to P2-29 for gain switching condition settings.

ASDA-A2**Chapter 8 Servo Parameters**

P2 - 06	KVI	Speed Integral Compensation	Address: 020CH, 020DH
----------------	------------	------------------------------------	------------------------------

Default: 100

Related Section:

Applicable Control Mode: ALL

Section 6.3.6

Unit: rad/s

Range: 0 ~ 1023

Data Size: 16-bit

Display Format: Decimal

Settings:

This parameter is used to set the integral time of speed loop. When the value of speed integral compensation is increased, it can improve the speed response ability and decrease the speed control deviation. However, if the setting value is over high, it may generate vibration or noise.

P2 - 07	KVF	Speed Feed Forward Gain	Address: 020EH, 020FH
----------------	------------	--------------------------------	------------------------------

Default: 0

Related Section:

Applicable Control Mode: ALL

Section 6.3.6

Unit: %

Range: 0 ~ 100

Data Size: 16-bit

Display Format: Decimal

Settings:

This parameter is used to set the feed forward gain when executing speed control command. When using speed smooth command, increase gain can improve speed track deviation. When not using speed smooth command, decrease gain can improve the resonance condition of mechanical system.

P2 - 08	PCTL	Special Factory Setting	Address: 0210H, 0211H
----------------	-------------	--------------------------------	------------------------------

Default: 0

Related Section: N/A

Applicable Control Mode: ALL

Unit: N/A

Range: 0 ~ 65535

Data Size: 16-bit

Display Format: Decimal

Settings:

This parameter can be used to reset all parameters to their original factory settings and enable some parameters functions.

Reset parameters settings:

10: Users can reset all parameter values to factory defaults. All parameter values

will be reset after re-power the servo drive. (Before perform this settings, ensure that the status of the servo drive is "Servo Off".)

Enable parameters functions:

20: If P2-08 is set to 20, then the parameter P4-10 is enabled.

22: If P2-08 is set to 22, then the parameters P4-11~P4-19 are enabled.

30, 35: If P2-08 is set to 30 first, and then set to 35, the value of E-Cam (Electronic Cam) can be recorded.

406: If P2-08 is set to 406, then the Digital Output (DO) signal can be forced to be activated and the drive will enter into Force Output Control operation mode.

400: If P2-08 is set to 400, it can switch the Force Output Control operation mode to normal Digital Output (DO) Control operation mode.

Please note:

ASDA-A2 series L type models does not provide Electronic Cam (E-Cam) function.

P2 - 09	DRT	Bounce Filter	Address: 0212H, 0213H
----------------	------------	----------------------	------------------------------

Default: 2

Related Section:

Applicable Control Mode: ALL

Section 6.3.6

Unit: 2msec

Range: 0 ~ 20

Data Size: 16-bit

Display Format: Decimal

Settings:

For example, if P2-09 is set to 5, the bounce filter time is $5 \times 2\text{msec} = 10\text{msec}$.

When there are too much vibration or noises around environment, increasing this setting value (bounce filter time) can improve reliability. However, if the time is too long, it may affect the response time.

P2 - 10	D11	Digital Input Terminal 1 (D11)	Address: 0214H, 0215H
----------------	------------	---------------------------------------	------------------------------

Default: 101

Related Section: Table 8.A

Applicable Control Mode: ALL

Unit: N/A

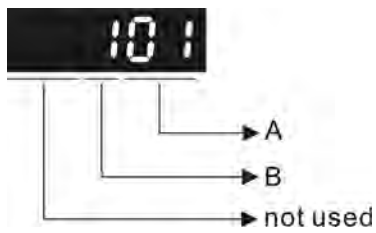
Range: 0 ~ 015Fh

Data Size: 16-bit

Display Format: Hexadecimal

Settings:

The parameters from P2-10 to P2-17 are used to determine the functions and statuses of D11 ~ D18.



A: DI (Digital Input) Function Settings:

For the setting value of P2- 10 ~ P2-17, please refer to Table 8.A.

B: DI (Digital Input) Enabled Status Settings:

0: Normally closed (contact b)

1: Normally open (contact a)

For example, when P2-10 is set to 101, it indicates that the function of DI1 is SON (Servo On, setting value is 0x01) and it requires a normally open contact to be connected to it.

Please re-start the servo drive after parameters have been changed.

Please note:

The parameter P3-06 is used to set how the Digital Inputs (DI) accept commands and signals through the external terminals or via the communication which is determined by parameter P4-07.

P2 - 11

DI2	Digital Input Terminal 2 (DI2)	Address: 0216H, 0217H
-----	--------------------------------	-----------------------

Default: 104

Related Section: Table 8.A

Applicable Control Mode: ALL

Unit: N/A

Range: 0 ~ 015Fh

Data Size: 16-bit

Display Format: Hexadecimal

Settings:

Refer to P2-10 for explanation.

P2 - 12

DI3	Digital Input Terminal 3 (DI3)	Address: 0218H, 0219H
-----	--------------------------------	-----------------------

Default: 116

Related Section: Table 8.A

Applicable Control Mode: ALL

Unit: N/A

Range: 0 ~ 015Fh

Data Size: 16-bit

Display Format: Hexadecimal

Settings:

Refer to P2-10 for explanation.

Chapter 8 Servo Parameters**ASDA-A2**

P2 - 13	DI4	Digital Input Terminal 4 (DI4)	Address: 021AH, 021BH
----------------	------------	---------------------------------------	------------------------------

Default: 117

Related Section: Table 8.A

Applicable Control Mode: ALL

Unit: N/A

Range: 0 ~ 015Fh

Data Size: 16-bit

Display Format: Hexadecimal

Settings:

Refer to P2-10 for explanation.

P2 - 14	DI5	Digital Input Terminal 5 (DI5)	Address: 021CH, 021DH
----------------	------------	---------------------------------------	------------------------------

Default: 102

Related Section: Table 8.A

Applicable Control Mode: ALL

Unit: N/A

Range: 0 ~ 015Fh

Data Size: 16-bit

Display Format: Hexadecimal

Settings:

Refer to P2-10 for explanation.

P2 - 15	DI6	Digital Input Terminal 6 (DI6)	Address: 021EH, 021FH
----------------	------------	---------------------------------------	------------------------------

Default: 22

Related Section: Table 8.A

Applicable Control Mode: ALL

Unit: N/A

Range: 0 ~ 015Fh

Data Size: 16-bit

Display Format: Hexadecimal

Settings:

Refer to P2-10 for explanation.

P2 - 16	DI7	Digital Input Terminal 7 (DI7)	Address: 0220H, 0221H
----------------	------------	---------------------------------------	------------------------------

Default: 23

Related Section: Table 8.A

Applicable Control Mode: ALL

Unit: N/A

Range: 0 ~ 015Fh

Data Size: 16-bit

Display Format: Hexadecimal

Settings:

Refer to P2-10 for explanation.

P2 - 17	DI8	Digital Input Terminal 8 (DI8)	Address: 0222H, 0223H
----------------	------------	---------------------------------------	------------------------------

Default: 21

Related Section: Table 8.A

Applicable Control Mode: ALL

Unit: N/A

Range: 0 ~ 015Fh

Data Size: 16-bit

Display Format: Hexadecimal

Settings:

Refer to P2-10 for explanation.

P2 - 18	DO1	Digital Output Terminal 1 (DO1)	Address: 0224H, 0225H
----------------	------------	--	------------------------------

Default: 101

Related Section: Table 8.B

Applicable Control Mode: ALL

Unit: N/A

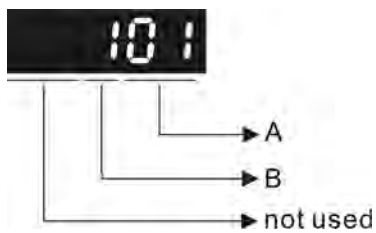
Range: 0 ~ 013Fh

Data Size: 16-bit

Display Format: Hexadecimal

Settings:

The parameters from P2-18 to P2-22 are used to determine the functions and statuses of DO1 ~ DO5.



A: DO Function Settings:

For the setting value of P2- 18 ~ P2-22, please refer to Table 8.A.

B: DO Enabled Status Settings:

0: Normally closed (contact b)

1: Normally open (contact a)

For example, when P2-18 is set to 101, it indicates that the function of DO1 is SRDY (Servo ready, setting value is 0x01) and it requires a normally open contact to be connected to it.

Please re-start the servo drive after parameters have been changed.

Chapter 8 Servo Parameters**ASDA-A2**

P2 - 19	DO2	Digital Output Terminal 2 (DO2)	Address: 0226H, 0227H
----------------	------------	--	------------------------------

Default: 103

Related Section: Table 8.B

Applicable Control Mode: ALL

Unit: N/A

Range: 0 ~ 013Fh

Data Size: 16-bit

Display Format: Hexadecimal

Settings:

Refer to P2-18 for explanation.

P2 - 20	DO3	Digital Output Terminal 3 (DO3)	Address: 0228H, 0229H
----------------	------------	--	------------------------------

Default: 109

Related Section: Table 8.B

Applicable Control Mode: ALL

Unit: N/A

Range: 0 ~ 013Fh

Data Size: 16-bit

Display Format: Hexadecimal

Settings:

Refer to P2-18 for explanation.

P2 - 21	DO4	Digital Output Terminal 4 (DO4)	Address: 022AH, 022BH
----------------	------------	--	------------------------------

Default: 105

Related Section: Table 8.B

Applicable Control Mode: ALL

Unit: N/A

Range: 0 ~ 013Fh

Data Size: 16-bit

Display Format: Hexadecimal

Settings:

Refer to P2-18 for explanation.

ASDA-A2**Chapter 8 Servo Parameters**

P2 - 22	DO5	Digital Output Terminal 5 (DO5)	Address: 022CH, 022DH
----------------	------------	--	------------------------------

Default: 7

Related Section: Table 8.B

Applicable Control Mode: ALL

Unit: N/A

Range: 0 ~ 013Fh

Data Size: 16-bit

Display Format: Hexadecimal

Settings:

Refer to P2-18 for explanation.

P2 - 23	NCF1	Notch Filter 1 (Resonance Suppression)	Address: 022EH, 022FH
----------------	-------------	---	------------------------------

Default: 1000

Related Section:

Applicable Control Mode: ALL

Section 6.3.7

Unit: Hz

Range: 50 ~ 1000

Data Size: 16-bit

Display Format: Decimal

Settings:

This parameter is used to set first resonance frequency of mechanical system. It can be used to suppress the resonance of mechanical system and reduce the vibration of mechanical system.

If P2-24 is set to 0, this parameter is disabled.

The parameters P2-23 and P2-24 are the first group of notch filter parameters and the parameters P2-43 and P2-44 are the second group of notch filter parameters.

P2 - 24	DPH1	Notch Filter Attenuation Rate 1 (Resonance Suppression)	Address: 0230H, 0231H
----------------	-------------	--	------------------------------

Default: 0

Related Section:

Applicable Control Mode: ALL

Section 6.3.7

Unit: dB

Range: 0 ~ 32

Data Size: 16-bit

Display Format: Decimal

Settings:

This parameter is used to set magnitude of the resonance suppression that is set by parameter P2-23. If P2-24 is set to 0, the parameters P2-23 and P2-24 are both disabled.

The parameters P2-23 and P2-24 are the first group of notch filter parameters and the parameters P2-43 and P2-44 are the second group of notch filter parameters.

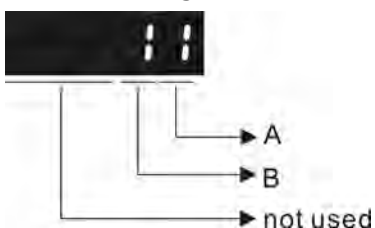
Chapter 8 Servo Parameters

ASDA-A2

P2 - 25	NLP	Low-pass Filter Time Constant (Resonance Suppression)	Address: 0232H, 0233H
	<p>Default: 2 (1kW and below models) or 5 (other models)</p> <p>Applicable Control Mode: ALL</p> <p>Unit: 0.1 msec</p> <p>Range: 0 ~ 1000</p> <p>Data Size: 16-bit</p> <p>Display Format: Decimal</p> <p>Settings:</p> <p>This parameter is used to set low-pass filter time constant of resonance suppression. If P2-25 is set to 0, this parameter is disabled.</p>		<p>Related Section: Section 6.3.7</p>

P2 - 26	DST	External Anti-Interference Gain	Address: 0234H, 0235H
	<p>Default: 0</p> <p>Applicable Control Mode: ALL</p> <p>Unit: 0.001</p> <p>Range: 0 ~ 1023</p> <p>Data Size: 16-bit</p> <p>Display Format: Decimal</p> <p>Settings:</p> <p>If P2-26 is set to 0, this parameter is disabled.</p>		<p>Related Section: N/A</p>

P2 - 27	GCC	Gain Switching Control Selection	Address: 0236H, 0237H
	<p>Default: 0</p> <p>Applicable Control Mode: ALL</p> <p>Unit: N/A</p> <p>Range: 0 ~ 4</p> <p>Data Size: 16-bit</p> <p>Display Format: Hexadecimal</p> <p>Settings:</p> <p>Gain Switching Condition Settings:</p>		<p>Related Section: N/A</p>



A: Gain Switching Condition Settings:

- 0: Disabled
- 1: Gain switching DI (Digital Input) signal (GAINUP) is On. (see Table 8.A)
- 2: In position mode, position deviation is higher than the setting value of P2-29.
- 3: Position command frequency is higher than the setting value of P2-29.
- 4: Servo motor speed is higher than the setting value of P2-29.
- 5: Gain switching DI (Digital Input) signal (GAINUP) is Off. (see Table 8.A)
- 6: In position mode, position deviation is lower than the setting value of P2-29.
- 7: Position command frequency is lower than the setting value of P2-29.
- 8: Servo motor speed is lower than the setting value of P2-29.

B: Gain Switching Control Settings:

- 0: Gain multiple switching
- 1: P → PI switching

Setting	P mode	S mode	Status
0	P2-00 × 100% P2-04 × 100%	P2-04 × 100%	Before switching
	P2-00 × P2-01 P2-04 × P2-05	P2-04 × P2-05	After switching
1	P2-06 × 0% P2-26 × 0%		Before switching
	P2-06 × 100% P2-26 × 100%		After switching

P2 - 28

GUT	Gain Switching Time Constant	Address: 0238H, 0239H
-----	------------------------------	-----------------------

Default: 10

Related Section: N/A

Applicable Control Mode: ALL

Unit: 10msec

Range: 0 ~ 1000

Data Size: 16-bit

Display Format: Decimal

Settings:

This parameter is used to set the time constant when switching the smooth gain.

If P2-28 is set to 0, this parameter is disabled.

Chapter 8 Servo Parameters

ASDA-A2

P2 - 29	GPE	Gain Switching Condition	Address: 023AH, 023BH
----------------	------------	---------------------------------	------------------------------

Default: 1280000

Related Section: N/A

Applicable Control Mode: ALL

Unit: pulse, Kpps, r/min

Range: 0 ~ 3840000

Data Size: 32-bit

Display Format: Decimal

Settings:

This parameter is used to set the value of gain switching condition (pulse error, Kpps, r/min) selected in P2-27. The setting value will be different depending on the different gain switching condition.

P2 - 30	INH	Auxiliary Function	Address: 023CH, 023DH
----------------	------------	---------------------------	------------------------------

Default: 0

Related Section: N/A

Applicable Control Mode: ALL

Unit: N/A

Range: -8 ~ +8

Data Size: 16-bit

Display Format: Decimal

Settings:

0: Disabled all functions described below.

1: Force the servo drive to be Servo On (upon software)

2: Reserved

3: Reserved

4: Reserved

5: After setting P2-30 to 5, the setting values of all parameters will lost (not remain in EEPROM) at power-down. When the parameters data are no more needed, using this mode can allows users not to save parameters data into memory without damaging the EEPROM. P2-30 should be set to 5 when using communication control function.

6: After setting P2-30 to 6, the servo drive will enter into Simulation mode. At this time, DO signal SRDY (Servo ready) will be activated. The servo drive can accept commands in each mode and monitor the commands via Data Scope function provided by ASDA-A2-Soft software program. But, the servo motor will not run when the servo drive in Simulation mode. This setting is only used to check and ensure the command is correct. It indicates the external Servo On signal is disabled in this mode, and therefore the motor fault messages such as overcurrent, overload, or overspeed, etc. will not display. The parameter P0-01 displays external fault messages such as reverse inhibit limit, forward inhibit limit, or emergency stop, etc. only.

7: (available in firmware version V1.013 and later models)

After setting P2-30 to 7, high-speed oscilloscope and time out function will be disabled (PC software setting).

8: (available in firmware version V1.013 and later models)

After setting P2-30 to 8, the system will backup all parameters (current value) and save them to EEPROM. The current value of the backup parameters will not lost after re-start the servo drive. When backup function is executed, "to.rom " is displayed (backup function can be executed when Servo On).

-1, -5, -6, -7: (available in firmware version V1.013 and later models)

Disable the function of setting value 1, 5, 6 and 7.

-2, -3, -4, -8: Reserved

Please note:

1. Please set P2-30 to 0 during normal operation.
2. When the communication control function is used, ensure that P2-30 is set to 5.
3. The setting value of P2-30 will return to 0 automatically after re-power the servo drive.

P2 - 31	AUT1	Speed Frequency Response Level in Auto and Semi-Auto Mode	Address: 023EH, 023FH
	Default: 80		Related Section: Section 5.6,
	Applicable Control Mode: ALL		Section 6.3.6
	Unit: Hz		
	Range: 1 ~ 1000		
	Data Size: 16-bit		
	Display Format: Hexadecimal		
	Settings:		
	This parameter allows the users to set the speed frequency response level of auto-tuning and semi-auto tuning mode. The speed frequency response settings are as follows:		
	1 ~ 50Hz : Low stiffness and low frequency response		
	51 ~ 250Hz : Medium stiffness and medium frequency response		
	251 ~ 850Hz : High stiffness and high frequency response		
	851 ~ 1000Hz : Extremely high stiffness and extremely high frequency response		
	Please note:		
	1. The servo drive will set the position frequency response according to the setting value of P2-31.		
	2. This parameter is activated by P2-32. Please refer to Section 5.6 for the tuning procedure and the related settings.		

P2 - 32▲	AUT2	Tuning Mode Selection	Address: 0240H, 0241H
Default: 0		Related Section: Section 5.6,	
Applicable Control Mode: ALL		Section 6.3.6	
Unit: N/A			
Range: 0 ~ 2			
Data Size: 16-bit			
Display Format: Hexadecimal			
Settings:			
0: Manual mode			
1: Auto Mode [Continuous adjustment]			
2: Semi-Auto Mode [Non-continuous adjustment]			
Explanation of manual mode:			
<ol style="list-style-type: none"> When P2-32 is set to mode#0, the setting value of P2-00, P2-02, P2-04, P2-06, P2-07, P2-25 and P2-26 can be user-defined. When switching mode #1 or #2 to #0, the setting value of P2-00, P2-02, P2-04, P2-06, P2-07, P2-25 and P2-26 will change to the value that measured in #1 auto-tuning mode or #2 semi-auto tuning mode. 			
Explanation of auto-tuning mode:			
<p>The servo drive will continuously estimate the system inertia, save the measured load inertia value automatically and memorized in P1-37 every 30 minutes by referring to the frequency response settings of P2-31.</p>			
<ol style="list-style-type: none"> When switching mode #1 or #2 to #0, the servo drive will continuously estimate the system inertia, save the measured load inertia value automatically and memorized in P1-37. Then, set the corresponding parameters according to this measured load inertia value. When switching mode#0 or #1 to #2, enter the appropriate load inertia value in P1-37. When switching mode#1 to #0, the setting value of P2-00, P2-04 and P2-06 will change to the value that measured in #1 auto-tuning mode. 			
Explanation of semi-auto tuning mode:			
<ol style="list-style-type: none"> When switching mode #2 to #0, the setting value of P2-00, P2-04, P2-06, P2-25 and P2-26 will change to the value that measured in #1 auto-tuning mode. After the system inertia becomes stable (The display of P2-33 will show 1), it will stop estimating the system inertia, save the measured load inertia value automatically, and memorized in P1-37. However, when P2-32 is set to mode#1 or #2, the servo drive will continuously perform the adjustment for a period of time. When the value of the system inertia becomes over high, the display of P2-33 will show 0 and the servo drive will start to adjust the load inertia value continuously. 			

ASDA-A2**Chapter 8 Servo Parameters**

P2 - 33▲	AUT3	Semi-Auto Mode Inertia Adjustment Selection	Address: 0242H, 0243H
-----------------	-------------	--	------------------------------

Default: 0

Related Section: N/A

Applicable Control Mode: ALL

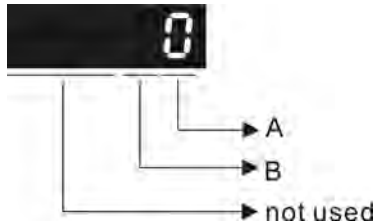
Unit: N/A

Range: 0 ~ 1

Data Size: 16-bit

Display Format: Decimal

Settings:



When the setting value of A is set to 0 or display is 0, it indicates that the load inertia estimation of semi-auto tuning mode has been executed but not been completed yet.

When the setting value of A is set to 1, it indicates that the load inertia estimation of semi-auto tuning mode has been completed. The measured load inertia is memorized in P1-37. If P2-33 is reset to 0, the servo drive will perform continuous adjustment for estimating the load inertia (P1-37) again.

B: Reserved.

P2 - 34	SDEV	Overspeed Warning Condition	Address: 0244H, 0245H
----------------	-------------	------------------------------------	------------------------------

Default: 5000

Related Section: N/A

Applicable Control Mode: S

Unit: r/min

Range: 1 ~ 5000

Data Size: 16-bit

Display Format: Decimal

Settings:

This parameter is used to set the over speed threshold that is used to determine the over speed fault condition. When the difference in speed between the desired speed and actual motor speed is over than the setting value of parameter P2-34, the servo fault, Overspeed (AL007) will be activated.

P2 - 35	PDEV	Excessive Error Warning Condition	Address: 0246H, 0247H
----------------	-------------	--	------------------------------

Default: 3840000

Related Section: N/A

Applicable Control Mode: PT, PR

Unit: pulse

Range: 1 ~ 128000000

Data Size: 32-bit

Display Format: Decimal

Settings:

This parameter is used to set the position deviation excessive error threshold that is used to determine the excessive deviation fault condition. When the difference in pulse number between the desired position and actual motor position is over than the setting value of parameter P2-35, the servo fault, Excessive Deviation (AL009) will be activated.

P2 - 36	EDI9	External Digital Input Terminal 9 (EDI9)	Address: 0248H, 0249H
----------------	-------------	---	------------------------------

Default: 0

Related Section: Table 8.A

Applicable Control Mode: ALL

Unit: N/A

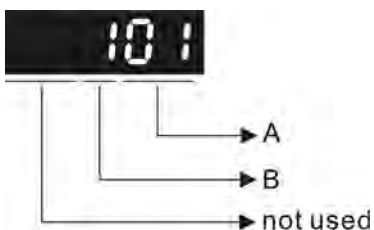
Range: 0 ~ 015Fh

Data Size: 16-bit

Display Format: Hexadecimal

Settings:

The parameters from P2-36 to P2-41 are used to determine the functions and statuses of external DI9 ~ DI14.



A: DI (Digital Input) Function Settings:

For the setting value of P2- 36 ~ P2-41, please refer to Table 8.A.

B: External DI (Digital Input) Enabled Status Settings:

0: Normally closed (contact b)

1: Normally open (contact a)

For example, when P2-36 is set to 101, it indicates that the function of EDI9 is SON (Servo On, setting value is 0x01) and it requires a normally open contact to be connected to it.

Please re-start the servo drive after parameters have been changed.

ASDA-A2**Chapter 8 Servo Parameters**

P2 - 37	EDI10	External Digital Input Terminal 10 (EDI10)	Address: 024AH, 024BH
----------------	--------------	---	------------------------------

Default: 0

Related Section: Table 8.A

Applicable Control Mode: ALL

Unit: N/A

Range: 0 ~ 015Fh

Data Size: 16-bit

Display Format: Hexadecimal

Settings:

Refer to P2-36 for explanation.

P2 - 38	EDI11	External Digital Input Terminal 11 (EDI11)	Address: 024CH, 024DH
----------------	--------------	---	------------------------------

Default: 0

Related Section: Table 8.A

Applicable Control Mode: ALL

Unit: N/A

Range: 0 ~ 015Fh

Data Size: 16-bit

Display Format: Hexadecimal

Settings:

Refer to P2-36 for explanation.

P2 - 39	EDI12	External Digital Input Terminal 12 (EDI12)	Address: 024EH, 024FH
----------------	--------------	---	------------------------------

Default: N/A

Related Section: Table 8.A

Applicable Control Mode: ALL

Unit: N/A

Range: 0 ~ 015Fh

Data Size: 16-bit

Display Format: Hexadecimal

Settings:

Refer to P2-36 for explanation.

Chapter 8 Servo Parameters**ASDA-A2**

P2 - 40	EDI13	External Digital Input Terminal 13 (EDI13)	Address: 0250H, 0251H
----------------	--------------	---	------------------------------

Default: N/A

Related Section: Table 8.A

Applicable Control Mode: ALL

Unit: N/A

Range: 0 ~ 015Fh

Data Size: 16-bit

Display Format: Hexadecimal

Settings:

Refer to P2-36 for explanation.

P2 - 41	EDI14	External Digital Input Terminal 14 (EDI14)	Address: 0252H, 0253H
----------------	--------------	---	------------------------------

Default: N/A

Related Section: Table 8.A

Applicable Control Mode: ALL

Unit: N/A

Range: 0 ~ 015Fh

Data Size: 16-bit

Display Format: Hexadecimal

Settings:

Refer to P2-36 for explanation.

P2 - 42	Reserved (Do Not Use)		
----------------	------------------------------	--	--

P2 - 43	NCF2	Notch Filter 2 (Resonance Suppression)	Address: 0256H, 0257H
----------------	-------------	---	------------------------------

Default: 1000

Related Section:

Applicable Control Mode: ALL

Section 6.3.7

Unit: Hz

Range: 50 ~ 2000

Data Size: 16-bit

Display Format: Decimal

Settings:

This parameter is used to set second resonance frequency of mechanical system. It can be used to suppress the resonance of mechanical system and reduce the vibration of mechanical system.

If P2-43 is set to 0, this parameter is disabled.

The parameters P2-23 and P2-24 are the first group of notch filter parameters and the parameters P2-43 and P2-44 are the second group of notch filter parameters.

ASDA-A2**Chapter 8 Servo Parameters**

P2 - 44	DPH2	Notch Filter Attenuation Rate 2 (Resonance Suppression)	Address: 0258H, 0259H
----------------	-------------	--	------------------------------

Default: 0

Related Section:

Applicable Control Mode: ALL

Section 6.3.7

Unit: dB

Range: 0 ~ 32

Data Size: 16-bit

Display Format: Decimal

Settings:

This parameter is used to set magnitude of the resonance suppression that is set by parameter P2-43. If P2-44 is set to 0, the parameters P2-43 and P2-44 are both disabled.

P2 - 45	NCF3	Notch Filter 3 (Resonance Suppression)	Address: 025AH, 025BH
----------------	-------------	---	------------------------------

Default: 1000

Related Section:

Applicable Control Mode: ALL

Section 6.3.7

Unit: Hz

Range: 50 ~ 2000

Data Size: 16-bit

Display Format: Decimal

Settings:

This parameter is used to set third resonance frequency of mechanical system. It can be used to suppress the resonance of mechanical system and reduce the vibration of mechanical system.

If P2-45 is set to 0, this parameter is disabled.

P2 - 46	DPH3	Notch Filter Attenuation Rate 3 (Resonance Suppression)	Address: 025CH, 025DH
----------------	-------------	--	------------------------------

Default: 0

Related Section:

Applicable Control Mode: ALL

Section 6.3.7

Unit: dB

Range: 0 ~ 32

Data Size: 16-bit

Display Format: Decimal

Settings:

This parameter is used to set magnitude of the resonance suppression that is set by parameter P2-45. If P2-46 is set to 0, the parameters P2-45 and P2-46 are both disabled.

Chapter 8 Servo Parameters

ASDA-A2

P2 - 47	ANCF	Auto Resonance Suppression Mode Selection	Address: 025EH, 025FH
----------------	-------------	--	------------------------------

Default: 1

Related Section: N/A

Applicable Control Mode: ALL

Unit: N/A

Range: 0 ~ 2

Data Size: 16-bit

Display Format: Decimal

Settings:

0: Disable Auto Resonance Suppression Mode.

The setting value of P2-23~P2-24 and P2-43~P2-46 will be fixed and will not be changed.

1: Auto Resonance Suppression Mode 1 [Non-continuous adjustment]

After the resonance is suppressed, the setting value of P2-23, P2-24, P2-43, P2-44, P2-45 and P2-46 will be fixed and will not be changed.

2: Auto Resonance Suppression Mode 2 [Continuous adjustment]

The servo drive will perform the resonance suppression continuously (will not stop).

The setting value of P2-23, P2-24, P2-43, P2-44, P2-45 and P2-46 will not be fixed.

When P2-47 is set to 1, the resonance suppression will be enabled automatically. After the mechanical system becomes stable, the setting value of P2-47 will return to 0. When the mechanical system is stable, the resonance suppression point will be memorized. When the mechanical system is not stable, if the servo drive is restarted or P2-47 is set to 1, the servo drive will estimate the resonance suppression point again.

When P2-47 is set to 2, the servo drive will perform the resonance suppression continuously. When the mechanical system becomes stable, the resonance suppression point will be memorized. When the mechanical system is not stable, if the servo drive is restarted, the servo drive will estimate the resonance suppression point again.

When switching the mode#1 or #2 to #0, the setting values of P2-43, P2-44, P2-45 and P2-46 will be saved automatically.

P2 - 48	ANCF	Auto Resonance Suppression Detection Level	Address: 0260H, 0261H
----------------	-------------	---	------------------------------

Default: 100

Related Section: N/A

Applicable Control Mode: ALL

Unit: N/A

Range: 1 ~ 300%

Data Size: 16-bit

Display Format: Decimal

Settings:

When the setting value is smaller, the system will become more sensitive to detect and find the resonance.

When the value of ↑

The setting value of P2-48 ↑, the sensitivity of detecting resonance ↓.

The setting value of P2-48 ↓, the sensitivity of detecting resonance ↑.

P2 - 49**SJIT****Speed Detection Filter and Jitter Suppression****Address: 0262H, 0263H**

Default: 0

Related Section: N/A

Applicable Control Mode: ALL

Unit: sec

Range: 0 ~ 1F

Data Size: 16-bit

Display Format: Decimal

Settings:

Setting Value of P2-49	Cutoff Frequency of Speed Loop Feedback (Hz)
00	2500
01	2250
02	2100
03	2000
04	1800
05	1600
06	1500
07	1400
08	1300
09	1200
0A	1100
0B	1000
0C	950
0D	900
0E	850
0F	800
10	750
11	700
12	650
13	600
14	550
15	500
16	450
17	400
18	350

Chapter 8 Servo Parameters

ASDA-A2

Setting Value of P2-49	Cutoff Frequency of Speed Loop Feedback (Hz)
19	300
1A	250
1B	200
1C	175
1D	150
1E	125
1F	100

P2 - 50	DCLR	Pulse Deviation Clear Mode	Address: 0264H, 0265H
----------------	-------------	-----------------------------------	------------------------------

Default: 0

Related Section: N/A

Applicable Control Mode: PT, PR

Unit: N/A

Range: 0 ~ 2

Data Size: 16-bit

Display Format: Hexadecimal

Settings:

For digital input function (DI function), please refer to Table 8.A.

This pulse deviation clear function is enabled when a digital input is set to pulse clear function (CCLR mode, DI (Digital Input) setting value is 0x04). When this input is triggered, the position accumulated pulse number will be clear to 0. (available in PT and PR mode only)

0: CCLR is triggered by rising-edge

1: CCLR is triggered by level

P2 - 51	Reserved (Do Not Use)		
P2 - 52	Reserved (Do Not Use)		

P2 - 53	KPI	Position Integral Compensation	Address: 026AH, 026BH
----------------	------------	---------------------------------------	------------------------------

Default: 0

Related Section:

Applicable Control Mode: ALL

Section 6.3.6

Unit: rad/s

Range: 0 ~ 1023

Data Size: 16-bit

Display Format: Decimal

Settings:

This parameter is used to set the integral time of position loop. When the value of position integral compensation is increased, it can decrease the position control deviation. However, if the setting value is over high, it may generate position overshoot or noise.

P2 - 54	Reserved (Do Not Use)
P2 - 55	Reserved (Do Not Use)
P2 - 56	Reserved (Do Not Use)
P2 - 57	Reserved (Do Not Use)
P2 - 58	Reserved (Do Not Use)
P2 - 59	Reserved (Do Not Use)

P2 - 60	GR4	Electronic Gear Ratio (2nd Numerator) (N2)	Address: 0278H, 0279H
----------------	------------	---	------------------------------

Default: 128

Related Section: N/A

Applicable Control Mode: PT

Unit: pulse

Range: 1 ~ (2²⁹-1)

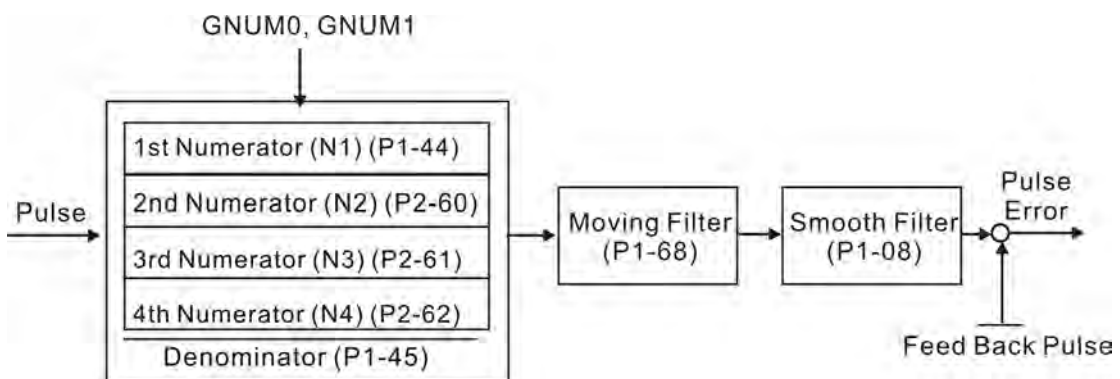
Data Size: 32-bit

Display Format: Decimal

Settings:

The electronic gear numerator value can be set via GNUM0, GNUM1 (refer to Table 8.A). When the GNUM0, GNUM1 are not defined, the default of gear numerator value is set by P1-44.

When the users wish to set the gear numerator value by using GNUM0, GNUM1, please set P2-60 ~ P2-62 after the servo motor has been stopped to prevent the mechanical system vibration.



Chapter 8 Servo Parameters**ASDA-A2**

P2 - 61	GR5	Electronic Gear Ratio (3rd Numerator) (N3)	Address: 027AH, 027BH
Default: 128		Related Section: N/A	
Applicable Control Mode: PT			
Unit: pulse			
Range: 1 ~ (2 ²⁹ -1)			
Data Size: 32-bit			
Display Format: Decimal			
Settings:			
Refer to P2-60 for explanation.			

P2 - 62	GR6	Electronic Gear Ratio (4th Numerator) (N4)	Address: 027CH, 027DH
Default: 128		Related Section: N/A	
Applicable Control Mode: PT			
Unit: pulse			
Range: 1 ~ (2 ²⁹ -1)			
Data Size: 32-bit			
Display Format: Decimal			
Settings:			
Refer to P2-60 for explanation.			

P2 - 63	Reserved (Do Not Use)
P2 - 64	Reserved (Do Not Use)

P2 - 65	GBIT	Special Function 1	Address: 0282H, 0283H
----------------	-------------	---------------------------	------------------------------

Default: 0

Related Section: N/A

Applicable Control Mode: PR, PT, S

Unit: N/A

Range: 0 ~ 0xFF

Data Size: N/A

Display Format: N/A

Settings:

Bit15	Bit14	Bit13	Bit12	Bit11	Bit10	Bit9	Bit8	Bit7	Bit6	Bit5	Bit4	Bit3	Bit2	Bit1	Bit0
-------	-------	-------	-------	-------	-------	------	------	------	------	------	------	------	------	------	------

Bit1	Bit0
------	------

Bit0: DI SPD0/SPD1 speed command trigger mode

Bit0=0: by level

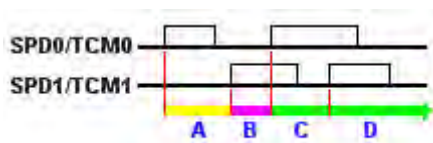
Bit0=1: by rising edge

Bit1: DI TCM0/TCM1 torque command trigger mode

Bit1=0: by level

Bit1=1: by rising edge

When the servo drive is rising-edge triggered, the internal commands work as follows:



A: Execute internal command 1

B: Execute internal command 2

C: Execute internal command 3

D: Execute internal command 3

Bit5	Bit4	Bit3	Bit2
------	------	------	------

Bit2 ~ Bit5: Reserved. Must be set to 0.

Bit6

Bit6: Abnormal pulse command detection (In PT mode)

Bit6=0: enable abnormal pulse command detection

Bit6=1: disable abnormal pulse command detection

Bit7

Bit7: Reserved. Must be set to 0.

Bit8

Bit8: U, V, W wiring error detection

Bit8=1: enable U, V, W wiring error detection

Bit9

Bit9: U, V, W wiring cut-off detection

Bit9=1: enable U, V, W wiring cut-off detection

Bit10

Bit10: DI ZCLAMP function selection

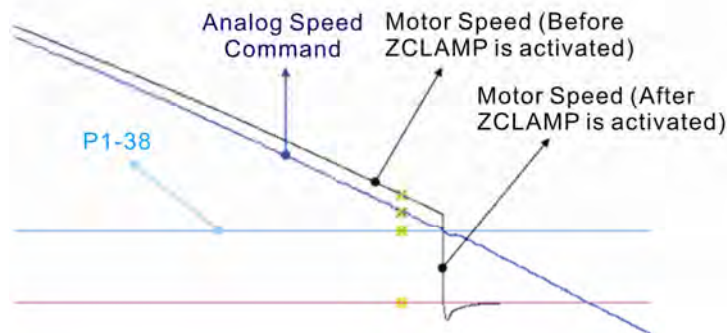
When the following conditions are all met, ZCLAMP function will be activated.

Condition1: Speed mode

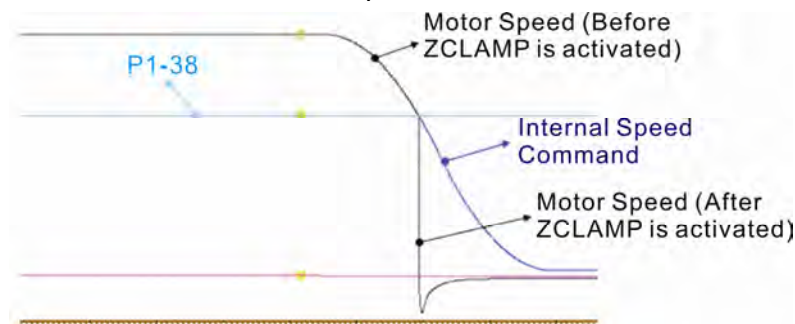
Condition2: DI ZCLAMP is activated.

Condition3: External analog speed command or internal register speed command is less than parameter P1-38.

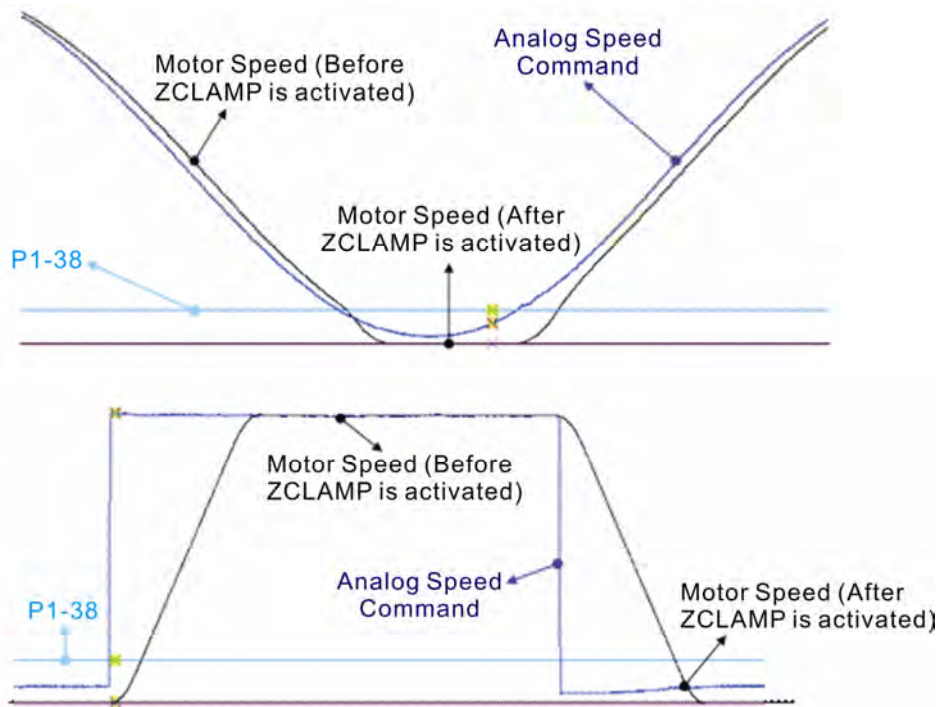
Bit10=0: When the command source is an analog speed command, the users can use ZCLAMP DI signal to stop the motor at the desire position and do not care the acceleration and deceleration speed curve of the analog speed command. The motor will be locked at the position when ZCLAMP conditions are satisfied.



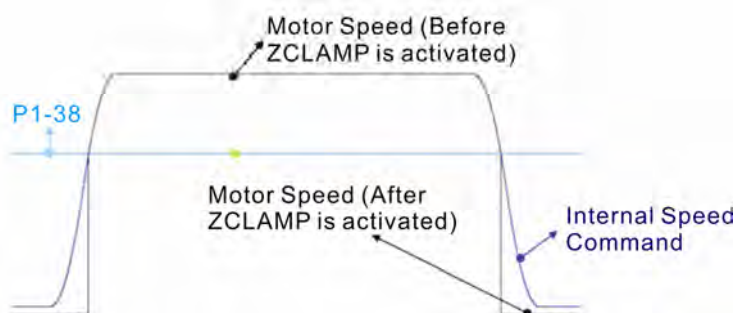
Bit10=0: When the command source is an internal speed command, the users can use ZCLAMP DI signal to stop the motor at the desire position and keep the the acceleration and deceleration speed curve of the internal speed command. The motor will be locked at the position when ZCLAMP conditions are satisfied.



Bit10=1: When the command source is an analog speed command, the users can use ZCLAMP DI signal to stop the motor at the desire position and do not care the acceleration and deceleration speed curve of the internal speed command. When ZCLAMP conditions are satisfied, the speed command is decreased to 0 r/min. When ZCLAMP conditions are not satisfied, the speed command will follow the analog speed command through Accel/Decel S-curve.



Bit10=1: When the command source is an internal speed command, the users can use ZCLAMP DI signal to stop the motor at the desire position and keep the acceleration and deceleration speed curve of the analog speed command. When ZCLAMP conditions are satisfied, the speed command is forced to 0 r/min directly.



B11

Bit11: NL(CWL)/PL(CCWL) pulse input inhibit function

Bit11=0: Disable NL(CWL)/PL(CCWL) pulse input inhibit function. In PT mode, no matter NL or PL exists or not, external position pulse command will be input into the servo drive.

Bit11=1: Enable NL(CWL)/PL(CCWL) pulse input inhibit function. In PT mode, if NL exists, the external NL pulse input into the servo drive will be inhibited and PL pulse input will be accepted. On the one hand, in PT mode, if PL exists, the external PL pulse input into the servo drive will be inhibited and PL pulse input will be accepted.

Please note:

If NL and PL both exist, NL and PL pulse input into the servo drive will be both inhibited.

Bit12

Bit12: Input power phase loss detection function

Bit12=0: Enable Input power phase loss (AL022) detection function

Bit12=1: Disable Input power phase loss (AL022) detection function

Bit13

Bit13: Encoder output error detection function

Bit13=0: Enable encoder output error (AL018) detection function

Bit13=1: Disable encoder output error (AL018) detection function

Bit14

Bit14: Reserved. Must be set to 0.

Bit15

Bit15: Friction Compensation Selection

Bit15=0: When external analog speed command or internal register speed command is less than parameter P1-38, the friction compensation value will not change.

Bit15=1: When external analog speed command or internal register speed command is less than parameter P1-38, the friction compensation value will change to 0(zero).

P2 - 66

GBIT2

Special Function 2

Address: 0284H, 0285H

Default: 0

Related Section: N/A

Applicable Control Mode: PR, PT, S

Unit: N/A

Range: 0 ~ 0x000F

Data Size: 16-bit

Display Format: Hexadecimal

Settings:

Bit7	Bit6	Bit5	Bit4	Bit3	Bit2	Bit1	Bit0
------	------	------	------	------	------	------	------

Bit1	Bit0
------	------

Bit0 ~ Bit1: Reserved. Must be set to 0.

Bit2

Bit2: Undervoltage (Servo Drive Fault) clear mode selection

Bit2=0: The fault, Undervoltage will not be cleared automatically.

Bit2=1: The fault, Undervoltage will be cleared automatically.

Bit3**Bit3: Reserved. Must be set to 0.****Bit4****Bit4: ALE44 disable selection**

Bit4=0: The fault, ALE44 is not disabled.

Bit4=1: The fault, ALE44 is disabled.

Bit5**Bit5: ALE41 disable selection (only available when full-close control function is enabled)**

Bit5=0: The fault, ALE41 is disabled.

Bit5=1: The fault, ALE41 is not disabled.

Bit7 **Bit6****Bit6 ~ Bit7: Reserved. Must be set to 0.****P2 - 67****JSL****Stable Inertia Estimating Time****Address: 0286H, 0287H**

Default: 1.5

Related Section: N/A

Applicable Control Mode: ALL

Unit: 0.1 times

Range: 0 ~ 200.0

Data Size: 16-bit

Display Format: Decimal

Settings:

In semi-auto tuning mode, after the servo drive continuously perform the adjustment for a period of time which is determined by P2-67, the system will consider that the system inertia has become stable and finish the operation of system inertia estimation.

Group 3: P3-xx Communication Parameters

P3 - 00	ADR	Communication Address Setting	Address: 0300H, 0301H
----------------	------------	--------------------------------------	------------------------------

Default: 0x7F

Related Section: Section 9.2

Applicable Control Mode: ALL

Unit: N/A

Range: 0x01 ~ 0x7F

Data Size: 16-bit

Display Format: Hexadecimal

Settings:

This parameter is used to set the communication slave address in hexadecimal format. This address is an absolute address which represents the servo drive on a RS-232/485 or CANbus network.

Display	0	0	Y	X
Range	-	-	0 ~ 7	0 ~ F

X: Axis number, the value must be within the range from 0 through F.

Y: Group number, the value must be within the range from 0 to through 7

If the AC servo drive is controlled by RS-232/485 communication, each drive (or device) must be uniquely identified. One servo drive only can set one address. If the address is duplicated, there will be a communication fault.

Please note:

1. This parameter does not provide broadcast function and does not respond insecurity.
2. When the address of host (external) controller is set to 0xFF, it is with auto-respond function. Then, the servo drive will receive from and respond to host (external) controller both no matter the address is matching or not. However, the parameter P3-00 cannot be set to 0xFF.

P3 - 01	BRT	Transmission Speed	Address: 0302H, 0303H
----------------	------------	---------------------------	------------------------------

Default: 0x0203

Related Section: Section 9.2

Applicable Control Mode: ALL

Unit: bps

Range: 0x0000 ~ 0x0405

Data Size: 16-bit

Display Format: Hexadecimal

Settings:

This parameter is used to set the baud rate and data transmission speed of the communications.

Display	0	Z	Y	X
COM Port	-	CAN	-	RS-232/485
Range	0	0 ~ 4	0	0 ~ 5

X: Baud rate setting

0: Baud rate 4800

1: Baud rate 9600

2: Baud rate 19200

3: Baud rate 38400

4: Baud rate 57600

5: Baud rate 115200

Y: Reserved. Must be set to 0.

Z: Data transmission speed setting.

0: 125K bits / second

1: 250K bits / second

2: 500K bits / second

3: 750K bits / second

4: 1.0M bits / second

Please note:

1. When setting this parameter via CANopen communication, only the setting of Z (data transmission speed setting) can be configured and other settings.
2. The communication transmission speed for USB can be set to 1.0M bits / second only and cannot be changed.

P3 - 02

PTL	Communication Protocol	Address: 0304H, 0305H
------------	-------------------------------	------------------------------

Default: 6

Related Section: Section 9.2

Applicable Control Mode: ALL

Unit: N/A

Range: 0 ~ 8

Data Size: 16-bit

Display Format: Hexadecimal

Settings:

This parameter is used to set the communication protocol. The alphanumeric characters represent the following: 7 or 8 is the number of data bits; N, E or O refers to the parity bit, Non, Even or Odd; the 1 or 2 is the numbers of stop bits.

0: Modbus ASCII mode, <7,N,2>

1: Modbus ASCII mode, <7,E,1 >

2: Modbus ASCII mode, <7,O,1>

3: Modbus ASCII mode, <8,N,2 >

- 4: Modbus ASCII mode, <8,E,1>
- 5: Modbus ASCII mode, <8,O,1>
- 6: Modbus RTU mode, <8,N,2>
- 7: Modbus RTU mode, <8,E,1>
- 8: Modbus RTU mode, <8,O,1>

P3 - 03	FLT	Transmission Fault Treatment	Address: 0306H, 0307H
----------------	------------	-------------------------------------	------------------------------

Default: 0

Related Section: Section 9.2

Applicable Control Mode: ALL

Unit: N/A

Range: 0 ~ 1

Data Size: 16-bit

Display Format: Hexadecimal

Settings:

This parameter is used to determine the operating sequence once a communication fault has been detected. If '1' is selected, the drive will stop operating upon detection the communication fault. The mode of stopping is set by parameter P1-32.

0: Display fault and continue operating

1: Display fault and decelerate to stop operating (deceleration time is determined by parameter P5-03)

P3 - 04	CWD	Communication Time Out Detection	Address: 0308H, 0309H
----------------	------------	---	------------------------------

Default: 0

Related Section: Section 9.2

Applicable Control Mode: ALL

Unit: sec

Range: 0 ~ 20

Data Size: 16-bit

Display Format: Decimal

Settings:

This parameter is used to set the maximum permissible time before detecting a fault due to communication time out. When P3-04 is set to a value over than 0, it indicates this parameter is enabled. However, if not communicating with the servo in this period of time, the servo drive will assume the communication has failed and show the communication error fault message.

When P3-04 is set to 0, this parameter is disabled.

ASDA-A2**Chapter 8 Servo Parameters**

P3 - 05	CMM	Communication Selection	Address: 030AH, 030BH
----------------	------------	--------------------------------	------------------------------

Default: 0

Related Section: Section 9.2

Applicable Control Mode: ALL

Unit: N/A

Range: 0x00 ~ 0x01

Data Size: 16-bit

Display Format: Hexadecimal

Settings:

Communication interface selection

0: RS-232

1: RS-485

Multiple communication modes RS232 and RS-485 cannot be used within one communication ring. Point-to-point connection or multidrop connection can be selected.

P3 - 06	SDI	Digital Input Communication Function	Address: 030CH, 030DH
----------------	------------	---	------------------------------

Default: 0

Related Section: Section 9.2

Applicable Control Mode: ALL

Unit: N/A

Range: 0x0000 ~ 0x3FFF

Data Size: 16-bit

Display Format: Hexadecimal

The setting of this parameter determines how the Digital Inputs (DI) accept commands and signals.

Bit0 ~ Bit 7 corresponds with DI1 ~ DI8. The least significant bit (Bit0) shows DI1 status and the most significant bit (Bit7) shows DI8 status.

Bit8 ~ Bit14 corresponds with EDI9 ~ EDI14.

Bit settings:

0: Digital input is controlled by external command (via CN1)

1: Digital input is controlled by parameter P4-07

For the settings of DI1 ~ DI8, please refer to P2-10 ~ P2-17.

For the settings of EDI9 ~ EDI14, please refer to P2-36 ~ P2-41.

This parameter P3-06 also works in conjunction with the parameter P4-07 which has several functions. Please see section 9.2 for details.

P3 - 07**CDT****Communication Response Delay Time****Address: 030EH, 030FH**

Default: 0

Related Section: Section 9.2

Applicable Control Mode: ALL

Unit: 1msec

Range: 0 ~ 1000

Data Size: 16-bit

Display Format: Decimal

Settings:

This parameter is used to delay the communication time that servo drive responds to host controller (external controller).

P3 - 08**MNS****Monitor Mode****Address: 0310H, 0311H**

Default: 0000

Related Section: Section 9.2

Applicable Control Mode: ALL

Unit: N/A

Range: refer to the description of Settings

Data Size: 16-bit

Display Format: Hexadecimal

Settings:

This parameter is used to monitor the data of the servo drive via communication. The monitor data can be displayed on PC upon the data scope function provided by ASDA-A2-Soft software.

Word	-	-	Low	High
Function	-	-	Monitor time at low speed	Monitor mode
Range	0	0	0 ~ F	0 ~ 3

H: Monitor mode, the value must be within the range from 0 through 3.

0: Disabled, i.e. disable monitor function.

1: Low-speed monitor mode. The sampling time is determined by the setting value of L and 4 channels can be monitored.

2: High-speed monitor mode. The sampling time is 8000 times per second and 4 channels can be monitored.

3: High-speed monitor mode. The sampling time is 16000 times per second and 2 channels can be monitored.

L: Sampling time in low-speed monitor mode (units: millisecond)

When the setting value of L is set (more than 0), the system will send a monitor message via USB device every L milliseconds to host controller so as to monitor the status of the servo drive. Each monitor message includes the data of 4 channels (16 bits x 4).

If the setting value of L is set to 0, it indicates that low-speed monitor function is disabled. Low-speed monitor function is enabled only when the setting value of H is set to 1.

P3 - 09

SYC	CANopen Synchronization Setting	Address: 0312H, 0313H
------------	--	------------------------------

Default: 0x57A1

Related Section: Section 9.2

Applicable Control Mode: CANopen

Unit: N/A

Range: refer to the description of Settings

Data Size: 16-bit

Display Format: Hexadecimal

Settings:

This parameter is used to set the CANopen slave to be synchronized with the CANopen master through synchronization signal. Although this parameter allows the users to execute manual adjustment, if not necessary, we do not recommend users to change the default setting manually.

Display	E	T	D	M
Function	SYNC error range	Target value	Dead zone range	Clock correction setting
Range	1 ~ 9	0 ~ 9	0 ~ F	1 ~ F

M: Clock correction setting, the value must be within the range from 1 through F, and the unit is usec.

When setting the CANopen slave to be synchronized with the CANopen master, the clock of the servo drive must be corrected. This function is used to set the maximum correction everytime.

D: Dead zone range, the value must be within the range from 0 through F, and the unit is usec.

When the difference between actual value and target value of SYNC signal reach time does not exceed the dead zone range, the clock correction does not need to be changed.

T: Target value of SYNC signal reach time, the value must be within the range from 0 through 9, and the standard value of SYNC signal reach time is 500 usec.

Target reach time of synchronization signal = 400 + 10 x setting value of T.

For example:

When T is set to 5, the target reach time of synchronization signal = 400 + 10 x 5 = 450

There should be a buffer between the target value and the standard value. The target value should be less than the standard value. If the target value is above than the standard value, an error may occur.

E: SYNC error range, the value must be within the range from 1 through 9, and the unit is 10 usec.

When the difference between actual value and target value of SYNC signal reach time is below this range, it indicates that the CANopen slave synchronize with the CANopen master through synchronization signal.

P3 - 10

Reserved (Do Not Use)

P3 - 11

Reserved (Do Not Use)

Group 4: P4-xx Diagnosis Parameters

P4 - 00★	ASH1	Fault Record (N)	Address: 0400H, 0401H
-----------------	-------------	-------------------------	------------------------------

Default: 0

Related Section:

Applicable Control Mode: ALL

Section 4.4.2

Unit: N/A

Range: N/A

Data Size: 32-bit

Display Format: Hexadecimal

Settings:

This parameter is used to set the most recent fault record.

Display of Low Word: LXXXX: It indicates the fault code, i.e. alarm code

Display of High Word: hYYYY: It indicates the corresponding CANopen error code.

P4 - 01★	ASH2	Fault Record (N-1)	Address: 0402H, 0403H
-----------------	-------------	---------------------------	------------------------------

Default: 0

Related Section:

Applicable Control Mode: ALL

Section 4.4.2

Unit: N/A

Range: N/A

Data Size: 32-bit

Display Format: Hexadecimal

Settings:

This parameter is used to set the second most recent fault record.

P4 - 02★	ASH3	Fault Record (N-2)	Address: 0404H, 0405H
-----------------	-------------	---------------------------	------------------------------

Default: 0

Related Section:

Applicable Control Mode: ALL

Section 4.4.2

Unit: N/A

Range: N/A

Data Size: 32-bit

Display Format: Hexadecimal

Settings:

This parameter is used to set the third most recent fault record.

Chapter 8 Servo Parameters

ASDA-A2

P4 - 03★	ASH4	Fault Record (N-3)	Address: 0406H, 0407H
-----------------	-------------	---------------------------	------------------------------

Default: 0

Related Section:

Applicable Control Mode: ALL

Section 4.4.2

Unit: N/A

Range: N/A

Data Size: 32-bit

Display Format: Hexadecimal

Settings:

This parameter is used to set the fourth most recent fault record.

P4 - 04★	ASH5	Fault Record (N-4)	Address: 0408H, 0409H
-----------------	-------------	---------------------------	------------------------------

Default: 0

Related Section:

Applicable Control Mode: ALL

Section 4.4.2

Unit: N/A

Range: N/A

Data Size: 32-bit

Display Format: Hexadecimal

Settings:

This parameter is used to set the fifth most recent fault record.

P4 - 05	JOG	JOG Operation	Address: 040AH, 040BH
----------------	------------	----------------------	------------------------------

Default: 20

Related Section:

Applicable Control Mode: ALL

Section 4.4.2

Unit: r/min

Range: 0 ~ 5000

Data Size: 16-bit

Display Format: Decimal

Settings:

JOG operation command:

1. Operation Test

- (1) Press the SET key to display the JOG speed. (The default value is 20 r/min).
- (2) Press the UP or DOWN arrow keys to increase or decrease the desired JOG speed. (This also can be undertaken by using the SHIFT key to move the cursor to the desired unit column (the effected number will flash) then changed using the UP and DOWN arrow keys).
- (3) Press the SET when the desired JOG speed is displayed. The Servo Drive will display "JOG".

- (4) Press the UP or DOWN arrow keys to jog the motor either P(CCW) or N(CW) direction. The motor will only rotation while the arrow key is activated.
- (5) To change JOG speed again, press the MODE key. The servo Drive will display "P4 - 05". Press the SET key and the JOG speed will displayed again. Refer back to #(2) and #(3) to change speed.
- (6) In JOG operation mode, if any fault occurs, the motor will stop running. The maximum JOG speed is the rated speed of the servo motor.

2. DI Signal Control

Set the value of DI signal as JOGU and JOGD (refer to Table 8.A).

Users can perform JOG run forward and run reverse control.

3. Communication Control

To perform a JOG Operation via communication command, use communication addresses 040AH and 040BH.

- (1) Enter 1 ~ 5000 for the desired JOG speed
- (2) Enter 4998 to JOG in the P(CCW) direction
- (3) Enter 4999 to JOG in the N(CW) direction
- (4) Enter 0 to stop the JOG operation

Please note that when using communication control, please set P2-30 to 5 to avoid that there are excessive writes to the system flash memory.

P4 - 06


FOT	Force Output Contact Control	Address: 040CH, 040DH
------------	-------------------------------------	------------------------------

Default: 0

Related Section:

Applicable Control Mode: ALL

Section 4.4.3

Unit: N/A

Range: 0 ~ 0xFF

Data Size: 16-bit

Display Format: Hexadecimal

Settings:

The function of Digital Outout (DO) is determined by the DO setting value. The user can set DO setting value (0x30 ~ 0x3F) via communication and then write the values into P4-06 to complete the settings.

Bit00 corresponds with DO setting value 0x30

Bit01 corresponds with DO setting value 0x31

Bit02 corresponds with DO setting value 0x32

Bit03 corresponds with DO setting value 0x33

Bit04 corresponds with DO setting value 0x34

Bit05 corresponds with DO setting value 0x35

Bit06 corresponds with DO setting value 0x36

Bit07 corresponds with DO setting value 0x37

Bit08 corresponds with DO setting value 0x38

Bit09 corresponds with DO setting value 0x39

Bit10 corresponds with DO setting value 0x3A

Bit11 corresponds with DO setting value 0x3B

Bit12 corresponds with DO setting value 0x3C

Bit13 corresponds with DO setting value 0x3D

Bit14 corresponds with DO setting value 0x3E

Bit15 corresponds with DO setting value 0x3F

For example:

When P2-18 is set to 0x0130, it indicates that the state of DO1 is the Bit00 state of P4-06.

This parameter can also be used to force the state of DO signal. Please refer to P2-18 ~ P2-22 to assign the functions of digital outputs (DO signals) and section 4.4.3 for the Force Outputs Operation.

P4 - 07	ITST	Input Status	Address: 040EH, 040FH
----------------	-------------	---------------------	------------------------------

Default: 0

Applicable Control Mode: ALL

Unit: N/A

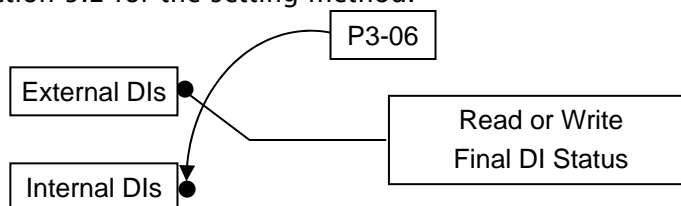
Range: 0 ~ 3FFF

Data Size: 16-bit

Display Format: Hexadecimal

Settings:

The control of digital inputs can be determined by the external terminals (DI1 ~ DI8, EDI9 ~ EDI14) or by the internal software digital inputs SDI1 ~ SDI14 (corresponds to Bit0 ~ Bit13 of P1-47) via communication (upon software). Please refer to P3-06 and section 9.2 for the setting method.



Read P4-07: Display the final status of DI input signal.

Write P1-47: Write the status of software digital inputs SDI1 ~ SDI14

(No matter the servo drive is controller through digital keypad or communication control, the function of this parameter is the same.)

For example:

External Control: Display the final status of DI input signal

When the read value of P4-07 is 0x0011, it indicates that DI1 and DI5 are ON.

Communication Control (Internal DIs): Read the status of input signal (upon software).

For example:

When the write value of P4-07 is 0x0011, it indicates that software digital inputs SDI1 and SDI5 are ON.

Bit0 ~ Bit7 corresponds with DI1 ~ DI8. Bit8 ~ Bit14 corresponds with EDI9 ~ EDI14.

For the settings of DI1 ~ DI8, please refer to P2-10 ~ P2-17. For the settings of EDI9 ~ EDI14, please refer to P2-36 ~ P2-41.

P4 - 08★	PKEY	Digital Keypad Input of Servo Drive	Address: 0410H, 0411H
-----------------	-------------	--	------------------------------

Default: N/A

Related Section: N/A

Applicable Control Mode: ALL

Unit: N/A

Range: Read only

Data Size: 16-bit

Display Format: Hexadecimal

Settings:

This parameter is used to check if MODE, UP, DOWN, SHIFT, and SET keys on the drive keypad being pressed or not. It is used to examine if these five keys work normally via communication during production.

P4 - 09★	MOT	Output Status	Address: 0412H, 0413H
-----------------	------------	----------------------	------------------------------

Default: 0

Related Section:

Applicable Control Mode: ALL

Section 4.4.5

Unit: N/A

Range: 0 ~ 0x1F

Data Size: 16-bit

Display Format: Hexadecimal

Settings:

There is no difference when reading DO output signal via the drive keypad or the communication. For the status of DO output signal, please refer to P2-18 ~ P2-22.

P4 - 10	CEN	Adjustment Function	Address: 0414H, 0415H
----------------	------------	----------------------------	------------------------------

Default: 0

Related Section: N/A

Applicable Control Mode: ALL

Unit: N/A

Range: 0 ~ 6

Data Size: 16-bit

Display Format: Decimal

Settings:

0: Reserved

1: Execute analog speed input drift adjustment

2: Execute analog torque input drift adjustment

3: Execute current detector (V phase) drift adjustment

4: Execute current detector (W phase) drift adjustment

5: Execute drift adjustment of the above 1~4

6: Execute IGBT NTC calibration

Please note:

1. This adjustment function is enabled after parameter P2-08 is set to 20.
2. When executing any adjustment, the external wiring connected to analog speed or torque must be removed and the servo system should be off (Servo off).

P4 - 11	SOF1	Analog Speed Input Drift Adjustment 1	Address: 0416H, 0417H
----------------	-------------	--	------------------------------

Default: Factory setting

Related Section: N/A

Applicable Control Mode: ALL

Unit: N/A

Range: 0 ~ 32767

Data Size: 16-bit

Display Format: Decimal

Settings:

The adjustment functions from P4-11 through P4-19 are enabled after parameter P2-08 is set to 22. Although these parameters allow the users to execute manual adjustment, we still do not recommend the users to change the default setting value of these parameters (P4-11 ~ P4-19) manually.

Please note that when P2-08 is set to 10, the users cannot reset this parameter.

ASDA-A2**Chapter 8 Servo Parameters**

P4 - 12	SOF2	Analog Speed Input Drift Adjustment 2	Address: 0418H, 0419H
----------------	-------------	--	------------------------------

Default: Factory setting

Related Section: N/A

Applicable Control Mode: ALL

Unit: N/A

Range: 0 ~ 32767

Data Size: 16-bit

Display Format: Decimal

Settings:

Refer to P4-11 for explanation.

Please note that when P2-08 is set to 10, the users cannot reset this parameter.

P4 - 13	TOF1	Analog Torque Drift Adjustment 1	Address: 041AH, 041BH
----------------	-------------	---	------------------------------

Default: Factory setting

Related Section: N/A

Applicable Control Mode: ALL

Unit: N/A

Range: 0 ~ 32767

Data Size: 16-bit

Display Format: Decimal

Settings:

Refer to P4-11 for explanation.

Please note that when P2-08 is set to 10, the users cannot reset this parameter.

P4 - 14	TOF2	Analog Torque Drift Adjustment 2	Address: 041CH, 041DH
----------------	-------------	---	------------------------------

Default: Factory setting

Related Section: N/A

Applicable Control Mode: ALL

Unit: N/A

Range: 0 ~ 32767

Data Size: 16-bit

Display Format: Decimal

Settings:

Refer to P4-11 for explanation.

Please note that when P2-08 is set to 10, the users cannot reset this parameter.

Chapter 8 Servo Parameters**ASDA-A2**

P4 - 15	COF1	Current Detector Drift Adjustment (V1 phase)	Address: 041EH, 041FH
----------------	-------------	---	------------------------------

Default: Factory setting

Related Section: N/A

Applicable Control Mode: ALL

Unit: N/A

Range: 0 ~ 32767

Data Size: 16-bit

Display Format: Decimal

Settings:

Refer to P4-11 for explanation.

Please note that when P2-08 is set to 10, the users cannot reset this parameter.

P4 - 16	COF2	Current Detector Drift Adjustment (V2 phase)	Address: 0420H, 0421H
----------------	-------------	---	------------------------------

Default: Factory setting

Related Section: N/A

Applicable Control Mode: ALL

Unit: N/A

Range: 0 ~ 32767

Data Size: 16-bit

Display Format: Decimal

Settings:

Refer to P4-11 for explanation.

Please note that when P2-08 is set to 10, the users cannot reset this parameter.

P4 - 17	COF3	Current Detector Drift Adjustment (W1 phase)	Address: 0422H, 0423H
----------------	-------------	---	------------------------------

Default: Factory setting

Related Section: N/A

Applicable Control Mode: ALL

Unit: N/A

Range: 0 ~ 32767

Data Size: 16-bit

Display Format: Decimal

Settings:

Refer to P4-11 for explanation.

Please note that when P2-08 is set to 10, the users cannot reset this parameter.

ASDA-A2**Chapter 8 Servo Parameters**

P4 - 18	COF4	Current Detector Drift Adjustment (W2 phase)	Address: 0424H, 0425H
----------------	-------------	---	------------------------------

Default: Factory setting

Related Section: N/A

Applicable Control Mode: ALL

Unit: N/A

Range: 0 ~ 32767

Data Size: 16-bit

Display Format: Decimal

Settings:

Refer to P4-11 for explanation.

Please note that when P2-08 is set to 10, the users cannot reset this parameter.

P4 - 19	TIGB	IGBT NTC Calibration	Address: 0426H, 0427H
----------------	-------------	-----------------------------	------------------------------

Default: Factory setting

Related Section: N/A

Applicable Control Mode: ALL

Unit: N/A

Range: 1 ~ 4

Data Size: 16-bit

Display Format: Decimal

Settings:

Refer to P4-11 for explanation.

When executing this auto adjustment, please ensure to cool the servo drive to 25°C.

Please note that when P2-08 is set to 10, the users cannot reset this parameter.

P4 - 20	DOF1	Analog Monitor Output Drift Adjustment (CH1)	Address: 0428H, 0429H
----------------	-------------	---	------------------------------

Default: Factory setting

Related Section:

Applicable Control Mode: ALL

Section 6.4.4

Unit: mV

Range: -800 ~ 800

Data Size: 16-bit

Display Format: Decimal

Settings:

Please note that when P2-08 is set to 10, the users cannot reset this parameter.

Chapter 8 Servo Parameters**ASDA-A2**

P4 - 21	DOF2	Analog Monitor Output Drift Adjustment (CH2)	Address: 042AH, 042BH
----------------	-------------	---	------------------------------

Default: Factory setting

Related Section:

Applicable Control Mode: ALL

Section 6.4.4

Unit: mV

Range: -800 ~ 800

Data Size: 16-bit

Display Format: Decimal

Settings:

Please note that when P2-08 is set to 10, the users cannot reset this parameter.

P4 - 22	SAO	Analog Speed Input Offset	Address: 042CH, 042DH
----------------	------------	----------------------------------	------------------------------

Default: 0

Related Section: N/A

Applicable Control Mode: S

Unit: mV

Range: -5000 ~ 5000

Data Size: 16-bit

Display Format: Decimal

Settings:

In speed mode, the users can use this parameter to add an offset value to analog speed input.

P4 - 23	TAO	Analog Torque Input Offset	Address: 042EH, 042FH
----------------	------------	-----------------------------------	------------------------------

Default: 0

Related Section: N/A

Applicable Control Mode: T

Unit: mV

Range: -5000 ~ 5000

Data Size: 16-bit

Display Format: Decimal

Settings:

In speed mode, the users can use this parameter to add an offset value to analog speed input.

ASDA-A2**Chapter 8 Servo Parameters**

P4 - 24	LVL	Undervoltage Error Level	Address: 0430H, 0431H
----------------	------------	---------------------------------	------------------------------

Default: 160

Related Section: N/A

Applicable Control Mode: ALL

Unit: V (rms)

Range: 140 ~ 190

Data Size: 16-bit

Display Format: Decimal

Settings:

When DC Bus voltage is lower than the value of $P4-24 \times \sqrt{2}$, the fault, Undervoltage will occur.

Group 5: P5-xx Motion Control Parameters

P5 - 00	Reserved (Do Not Use)
P5 - 01	Reserved (Do Not Use)
P5 - 02	Reserved (Do Not Use)

P5 - 03	PDEC	Deceleration Time of Protectin Function	Address: 0506H, 0507H
----------------	-------------	--	------------------------------

Default: 0XE0EFEEFF

Related Section: N/A

Applicable Control Mode: ALL

Unit: N/A

Range: 0x00000000 ~ 0xF0FFFFFF

Data Size: 32-bit

Display Format: Hexadecimal

Settings:

Display	High Word				Low Word			
	D	C	B	A	W	Z	Y	X
Function	STP	Reserved	CTO	OVF	SNL	SPL	NL	PL
Range	0 ~ F	-	0 ~ F	0 ~ F	0 ~ F	0 ~ F	0 ~ F	0 ~ F

This parameter is used to set motor deceleration when protection functions, such as STOP (Motor stop), OVF (Position command overflow), SNL (Reverse software limit), SPL (Forward software limit), NL (Reverse inhibit limit) or PL (Forward inhibit limit), etc. are activated.

1. Deceleration time of protection functions include: OVF, CTO(AL020), SPL, SNL, PL, NL
2. Deceleration time of motor stop command: STP

When entering P5-03, Lower Word display will show first. After pressing SHIFT key on the drive keypad, the High Word display will show next.

The values from 0 through F correspond with the setting values from P5-20 through P5-35.

For example, when the setting value X is set to A, it indicates that the motor PL deceleration time is determined by parameter P5-30.

P5 - 04	HMOV	Homing Mode	Address: 0508H, 0509H
----------------	-------------	--------------------	------------------------------

Default: 0

Related Section: N/A

Applicable Control Mode: PT, PR

Unit: N/A

Range: 0 ~ 0x128

Data Size: 16-bit

Display Format: Hexadecimal

Settings:

This parameter is used to determine the homing characteristics of the servo motor.

Display	W	Z	Y	X
Function	Reserved	Limit setting	Z pulse setting	Homing direction setting
Range	-	0 ~ 1	0 ~ 2	0 ~ 8
Settings	-	-	Y=0: Stop and return to Z pulse. Y=1: Go forward to Z pulse.	X=0: Move forward to PL(CCWL) used as home.
		-	Y=2: Ignore Z pulse	X=1: Move reverse to NL(CWL) used as home.
		When there is a limit: Z=0: After reaching the limit, activate the limit signal. Z=1: After reaching the limit, the motor will run in the reverse direction.		X=2: Move forward to dedicated home sensor (ORGP: OFF → ON)
				X=3: Move reverse to dedicated home sensor (ORGP: OFF → ON)
				X=4: Move forward and regard Z pulse as home sensor.
				X=5: Move reverse and regard Z pulse as home sensor.
				Y=0: Stop and return to Z pulse. Y=1: Go forward to Z pulse. Y=2: Ignore Z pulse
			X=7: Move reverse to dedicated home sensor (ORGP: ON → OFF)	
			X=8: Regard current position as home sensor	

P5 - 05**HSPD1****1st Speed Setting of High Speed Homing****Address: 050AH, 050BH**

Default: 100.0

Related Section: N/A

Applicable Control Mode: ALL

Unit: 0.1 r/min

Range: 1 ~ 2000.0

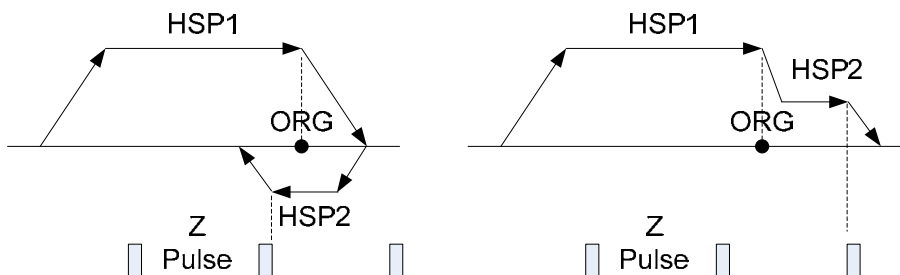
Data Size: 16-bit

Display Format: Decimal

Settings:

This parameter is used to set the initial (high speed) homing speed.

The homing operation of the servo motor involves two homing speed settings. When homing is triggered, the servo motor will proceed at a high speed until a home sensor is detected. The servo motor will then move reverse at a low speed until off of the home sensor, and finally will stop at the next Z pulse.

**P5 - 06****HSPD2****2nd Speed Setting of Low Speed Homing****Address: 050CH, 050DH**

Default: 20.0

Related Section: N/A

Applicable Control Mode: ALL

Unit: 0.1 r/min

Range: 1 ~ 500.0

Data Size: 16-bit

Display Format: Decimal

Settings:

This parameter is used to set the secondary (low speed) homing speed.

Refer to P5-06 for explanation.

P5 - 07**PRCM****Trigger Position Command (PR mode only)****Address: 050EH, 050FH**

Default: 0

Related Section: N/A

Applicable Control Mode: PR

Unit: N/A

Range: 0 ~ 1000

Data Size: 16-bit

Display Format: Decimal

Settings:

There are 64 stored positions can be programmed via a combination of the POS0 ~ POS5 commands. This parameter is used to trigger the dedicated position command in PR mode and command the motor to move to the dedicated position instead of using DI (Digital Input) CTRG and POS0 ~ POS5.

0: Start homing function.

When entering P5-07, the default setting value 0 will display. Pressing SET key on the drive keypad, the servo motor will start homing operation.

1 ~ 63: Trigger Position Command (This function is equivalent to the function of DI CTRG signal + POSn signal).

When P5-07 is set to 1 ~ 63, the dedicated position command can be triggered and the servo drive will command the motor move to the the dedicated position. For example, when P5-07 is set to 1, the position command P1 is triggered and the servo drive will command the motor to move to the position which correspond the position command P1.

64 ~ 9999: Write inhibit (Invaild setting value)

1000: Stop positioning.

When P5-07 is set to 1000, the motor stop command will be activated. This function is equivalent to the function of DI STOP signal.

The display value of P5-07:

1. When the motor does not receive the drive command (the motor is not running), if the users read P5-07 at this time, the display value of P5-07 will be the setting value of P5-07
2. When the position command is triggered and the motor start runningbut does not reach the dedicated position (during positioning, the motor is running), if the users read P5-07 at this time, the display value of P5-07 will be setting value of P5-07 plus 10000.
3. When the position command is triggered and the motor reaches the dedicated position (the positioning is completed and the motor stop running), if the users read P5-07 at this time, the display value of P5-07 will be setting value of P5-07 plus 20000.

For example, when P5-07 is set to 3, it indicates that the position command P3 will be triggered.

1. If the display value of P5-07 is 3, it indicates that the motor does not receive the drive command and the motor is not running.
2. If the display value of P5-07 is 100003, it indicates that the position command is triggered but the positioning is not completed.
3. If the display value of P5-07 is 200003, it indicates that the position command is triggered and the positioning is completed.

Chapter 8 Servo Parameters

ASDA-A2

P5 - 08	SWLP	Forward Software Limit	Address: 0510H, 0511H
----------------	-------------	-------------------------------	------------------------------

Default: 2147483647

Related Section: N/A

Applicable Control Mode: PR

Unit: PUU

Range: -2147483648 ~ +2147483647

Data Size: 32-bit

Display Format: Decimal

P5 - 09	SWLN	Reverse Software Limit	Address: 0512H, 0513H
----------------	-------------	-------------------------------	------------------------------

Default: -2147483648

Related Section: N/A

Applicable Control Mode: PR

Unit: PUU

Range: -2147483648 ~ +2147483647

Data Size: 32-bit

Display Format: Decimal

P5 - 10★	AYSZ	Data Array: Data Amount (N x 32 bits)	Address: 0514H, 0515H
-----------------	-------------	--	------------------------------

Default: N/A

Related Section: Section 7.2

Applicable Control Mode: ALL

Unit: N/A

Range: read only

Data Size: 16-bit

Display Format: Decimal

Settings:

This parameter is used to set the data amount of data array (N x 32 bits). N is the capacity of the data array.

P5 - 11■	AYID	Data Array: Read / Write Address	Address: 0516H, 0517H
-----------------	-------------	---	------------------------------

Default: 0

Related Section: Section 7.2

Applicable Control Mode: ALL

Unit: N/A

Range: 0 ~ (P5-10-1)

Data Size: 16-bit

Display Format: Decimal

Settings:

This parameter is used to set the data address when reading and writing data array.

ASDA-A2**Chapter 8 Servo Parameters**

P5 - 12	AYD0	Data Array: Read / Write Data Block 1	Address: 0518H, 0519H
----------------	-------------	--	------------------------------

Default: 0

Related Section: Section 7.2

Applicable Control Mode: ALL

Unit: N/A

Range: -2147483648 ~ +2147483647

Data Size: 32-bit

Display Format: Decimal

Settings:

This parameter is used to read the data block 0 of data array (Array[P5-11++]).

For example, when P5-11 is set to 100, the first read data displayed by P5-12 is the 100th data, the secondary read data is 101+1=102th data, the third read data is 102+1 = 103th data and vice versa. By the same logic, when P5-11 is set to 100, the first written data displayed by P5-12 is the 100th data, the secondary written data is 101+1=102th data, the third written data is 102+1 = 103th data and vice versa. However, if P5-12 is read via the drive keypad, only the 101th data will be read.

P5 - 13	AYD1	Data Array: Read / Write Data Block 2	Address: 051AH, 051BH
----------------	-------------	--	------------------------------

Default: 0

Related Section: Section 7.2

Applicable Control Mode: ALL

Unit: N/A

Range: -2147483648 ~ +2147483647

Data Size: 32-bit

Display Format: Decimal

Settings:

This parameter is used to read the data block 2 of data array (Array[P5-11++]).

The usage of this parameter is the same as the parameter P5-12. Only one function is different. When P5-12 is read via the drive keypad, the first read data displayed by P5-12 is the 100th data, the secondary read data is 101+1=102th data, the third read data is 102+1 = 103th data and vice versa. It indicates that using P5-13 can read more than one data via the drive keypad. Please note that using P5-13 can not write data via the drive keypad.

P5 - 14	Reserved (Do Not Use)
----------------	------------------------------

P5 - 15	PMEM	PATH 1 ~ PATH 2 Data Not Retained Setting	Address: 051EH, 051FH
----------------	-------------	--	------------------------------

Default: 0x0

Related Section: N/A

Applicable Control Mode: ALL

Unit: N/A

Range: 0x0 ~ 0x0011

Data Size: 16-bit

Display Format: Hexadecimal

Settings:

This parameter is designed for the users who need to change the positioning point frequently via communication.

Display	0	0	Y	X
Range	-	-	0 ~ 1	0 ~ 1

X=0: The data of PATH 1 (P6-02 ~P6-03) will be retained (memorized) when the power goes off.

X=1: The data of PATH 1 (P6-02 ~P6-03) will not be retained (memorized) when the power goes off.

Y=0: The data of PATH 2 (P6-04 ~P6-05) will be retained (memorized) when the power goes off.

Y=1: The data of PATH 2 (P6-04 ~P6-05) will not be retained (memorized) when the power goes off.

Other settings: Reserved

P5 - 16	AXEN	Axis Position: Motor Encoder	Address: 0520H, 0521H
----------------	-------------	-------------------------------------	------------------------------

Default: 0

Related Section: Section 7.3

Applicable Control Mode: ALL

Unit: PUU (user unit)

Range: -2147483648 ~ +2147483647

Data Size: 32-bit

Display Format: Decimal

Settings:

Read function: This parameter is used to read the actual position of the motor encoder, i.e. the monitor variable V000 + deviation value.

Write function (available in firmware V1.015 and later models only):

The users can write any value and doing this will no change the value of monitor variable V000 and will not affect the position coordinate either.

ASDA-A2**Chapter 8 Servo Parameters**

P5 - 17	AXPC	Axis Position: Auxiliary Encoder (Pulse Command Feedback)	Address: 0522H, 0523H
----------------	-------------	--	------------------------------

Default: N/A

Related Section: Section 7.3

Applicable Control Mode: ALL

Unit: pulse

Range: -2147483648 ~ +2147483647

Data Size: 32-bit

Display Format: Decimal

Settings:

This parameter is used to send back the pulse counts of the auxiliary encoder (linear scale).

P5 - 18	AXAU	Axis Position: Pulse Command	Address: 0524H, 0525H
----------------	-------------	-------------------------------------	------------------------------

Default: N/A

Related Section: Section 7.3

Applicable Control Mode: ALL

Unit: N/A

Range: -2147483648 ~ +2147483647

Data Size: 32-bit

Display Format: Decimal

Settings:

This parameter is used to send back the pulse counts of pulse command.

P5 - 19	TBS	E-Cam Curve Scaling	Address: 0526H, 0527H
----------------	------------	----------------------------	------------------------------

Default: 1.000000

Related Section: Section 7.3

Applicable Control Mode: PR

Unit: 0.000001 times, i.e. 1/ (10⁶)

Range: -2147.000000 ~ +2147.000000

Data Size: 32-bit

Display Format: Decimal

Settings: (available in firmware V1.017 and later models only)

This parameter is used to magnify or minify the E-Cam table without changing the setting value of the E-Cam table.

For example:

When the data of the table is 0,10,20,30,40,20, if the magnification is set to 2.000000, it is equal to the data 0,20,40,60,80,40 which the magnification is set to 1.000000.

When using the same pulse frequency of master axis to drive E-Cam operation, increasing the setting value of P5-19 will magnify the route of E-Cam operation and increase the operation speed as well.

Please note:

1. This parameter can be set any time. However, it is effective only when the electronic gear is engaged.
2. ASDA-A2 series L type models does not provide Electronic Cam (E-Cam) function.

P5 - 20	ACO	Accel / Decel Time 0	Address: 0528H, 0529H
----------------	------------	-----------------------------	------------------------------

Default: 200

Related Section:

Applicable Control Mode: PR

Section 7.10

Unit: msec

Range: 1 ~ 65500

Data Size: 16-bit

Display Format: Decimal

Settings:

In PR mode, this parameter is used to set the acceleration and deceleration time, i.e. the necessary time when the motor reaches the speed of 3000 r/min from 0.

P5 - 21	AC1	Accel / Decel Time 1	Address: 052AH, 052BH
----------------	------------	-----------------------------	------------------------------

Default: 300

Related Section:

Applicable Control Mode: PR

Section 7.10

Unit: msec

Range: 1 ~ 65500

Data Size: 16-bit

Display Format: Decimal

Settings:

Refer to P5-20 for explanation.

P5 - 22	AC2	Accel / Decel Time 2	Address: 052CH, 052DH
----------------	------------	-----------------------------	------------------------------

Default: 500

Related Section:

Applicable Control Mode: PR

Section 7.10

Unit: msec

Range: 1 ~ 65500

Data Size: 16-bit

Display Format: Decimal

Settings:

Refer to P5-20 for explanation.

ASDA-A2**Chapter 8 Servo Parameters**

P5 - 23	AC3	Accel / Decel Time 3	Address: 052EH, 052FH
----------------	------------	-----------------------------	------------------------------

Default: 600

Related Section:

Applicable Control Mode: PR

Section 7.10

Unit: msec

Range: 1 ~ 65500

Data Size: 16-bit

Display Format: Decimal

Settings:

Refer to P5-20 for explanation.

P5 - 24	AC4	Accel / Decel Time 4	Address: 0530H, 0531H
----------------	------------	-----------------------------	------------------------------

Default: 800

Related Section:

Applicable Control Mode: PR

Section 7.10

Unit: msec

Range: 1 ~ 65500

Data Size: 16-bit

Display Format: Decimal

Settings:

Refer to P5-20 for explanation.

P5 - 25	AC5	Accel / Decel Time 5	Address: 0532H, 0533H
----------------	------------	-----------------------------	------------------------------

Default: 900

Related Section:

Applicable Control Mode: PR

Section 7.10

Unit: msec

Range: 1 ~ 65500

Data Size: 16-bit

Display Format: Decimal

Settings:

Refer to P5-20 for explanation.

Chapter 8 Servo Parameters**ASDA-A2**

P5 - 26	AC6	Accel / Decel Time 6	Address: 0534H, 0535H
----------------	------------	-----------------------------	------------------------------

Default: 1000

Related Section:

Applicable Control Mode: PR

Section 7.10

Unit: msec

Range: 1 ~ 65500

Data Size: 16-bit

Display Format: Decimal

Settings:

Refer to P5-20 for explanation.

P5 - 27	AC7	Accel / Decel Time 7	Address: 0536H, 0537H
----------------	------------	-----------------------------	------------------------------

Default: 1200

Related Section:

Applicable Control Mode: PR

Section 7.10

Unit: msec

Range: 1 ~ 65500

Data Size: 16-bit

Display Format: Decimal

Settings:

Refer to P5-20 for explanation.

P5 - 28	AC8	Accel / Decel Time 8	Address: 0538H, 0539H
----------------	------------	-----------------------------	------------------------------

Default: 1500

Related Section:

Applicable Control Mode: PR

Section 7.10

Unit: msec

Range: 1 ~ 65500

Data Size: 16-bit

Display Format: Decimal

Settings:

Refer to P5-20 for explanation.

ASDA-A2**Chapter 8 Servo Parameters**

P5 - 29	AC9	Accel / Decel Time 9	Address: 053AH, 053BH
Default: 2000		Related Section:	
Applicable Control Mode: PR		Section 7.10	
Unit: msec			
Range: 1 ~ 65500			
Data Size: 16-bit			
Display Format: Decimal			
Settings:			
Refer to P5-20 for explanation.			

P5 - 30	AC10	Accel / Decel Time 10	Address: 053CH, 053DH
Default: 2500		Related Section:	
Applicable Control Mode: PR		Section 7.10	
Unit: msec			
Range: 1 ~ 65500			
Data Size: 16-bit			
Display Format: Decimal			
Settings:			
Refer to P5-20 for explanation.			

P5 - 31	AC11	Accel / Decel Time 11	Address: 053EH, 053FH
Default: 3000		Related Section:	
Applicable Control Mode: PR		Section 7.10	
Unit: msec			
Range: 1 ~ 65500			
Data Size: 16-bit			
Display Format: Decimal			
Settings:			
Refer to P5-20 for explanation.			

Chapter 8 Servo Parameters**ASDA-A2**

P5 - 32	AC12	Accel / Decel Time 12	Address: 0540H, 0541H
Default: 5000		Related Section:	
Applicable Control Mode: PR		Section 7.10	
Unit: msec			
Range: 1 ~ 65500			
Data Size: 16-bit			
Display Format: Decimal			
Settings:			
Refer to P5-20 for explanation.			

P5 - 33	AC13	Accel / Decel Time 13	Address: 0542H, 0543H
Default: 8000		Related Section:	
Applicable Control Mode: PR		Section 7.10	
Unit: msec			
Range: 1 ~ 65500			
Data Size: 16-bit			
Display Format: Decimal			
Settings:			
Refer to P5-20 for explanation.			

P5 - 34	AC14	Accel / Decel Time 14	Address: 0544H, 0545H
Default: 50		Related Section:	
Applicable Control Mode: PR		Section 7.10	
Unit: msec			
Range: 1 ~ 65500			
Data Size: 16-bit			
Display Format: Decimal			
Settings:			
The default setting value of this parameter is smaller and it is for the deceleration setting when protection function is activated.			

ASDA-A2**Chapter 8 Servo Parameters**

P5 - 35	AC15	Accel / Decel Time 15	Address: 0546H, 0547H
----------------	-------------	------------------------------	------------------------------

Default: 30

Related Section:

Applicable Control Mode: PR

Section 7.10

Unit: msec

Range: 1 ~ 65500

Data Size: 16-bit

Display Format: Decimal

Settings:

The default setting value of this parameter is smaller and it is for the deceleration setting when the motor stops in high speed.

P5 - 36	CAST	CAPTURE: Start Address of Data Array	Address: 0548H, 0549H
----------------	-------------	---	------------------------------

Default: 0

Related Section:

Applicable Control Mode: ALL

Section 7.11.1

Unit: N/A

Range: 0 ~ (P5-10-1)

Data Size: 16-bit

Display Format: Decimal

Settings:

This parameter is used to specify the start address which captures the first point data and save it into data array.

Please note:

This parameter can be set only when capture operation is stopped (Refer to P5-39).

P5 - 37	CAAX	CAPTURE: Axis Position CNT	Address: 054AH, 054BH
----------------	-------------	-----------------------------------	------------------------------

Default: 0

Related Section:

Applicable Control Mode: ALL

Section 7.11.1

Unit: N/A

Range: -2147483648 ~ +2147483647

Data Size: 32-bit

Display Format: Decimal

Settings:

This parameter can be set only when capture operation is stopped (Refer to P5-39).

Please note:

1. Do not change this parameter when the capture source is the motor encoder.
2. When the capture source is the motor encoder, the value of this parameter is reset to the motor encoder feedback position (monitor variable is 00h).

P5 - 38	CANO	CAPTURE: Capture Amount	Address: 054CH, 054DH
----------------	-------------	--------------------------------	------------------------------

Default: 1

Related Section:

Applicable Control Mode: ALL

Section 7.11.1

Unit: N/A

Range: 1 ~ (P5-10 - P5-36)

Data Size: 16-bit

Display Format: Decimal

Settings:

When the compare function is not enabled, using this parameter can set the estimated capture amount (able to read and write).

Once the capture function is enabled, everytime when one position is captured, the setting value of P5-38 will decrease 1. When the setting value of P5-38 is equal to 0, it indicates that the capture operation has finished.

Please note:

1. The total amount of COMPARE, CAPTURE and E-Cam data can not exceed the number of 800.
2. ASDA-A2 series L type models does not provide Electronic Cam (E-Cam) function.

P5 - 39	CACT	CAPTURE: Capture Source Setting	Address: 054EH, 054FH
----------------	-------------	--	------------------------------

Default: 0x2010

Related Section:

Applicable Control Mode: ALL

Section 7.11.1

Unit: N/A

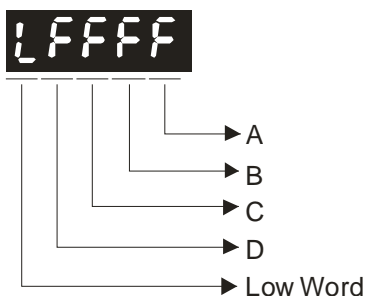
Range: 0x0000 ~ 0xF13F

Data Size: 16-bit

Display Format: Hexadecimal

Settings:

This parameter is used to determine the capture source and enable the capture function.



A: Capture function settings:

Please refer to the following table and descriptions:

Bit	3	2	1	0
Function	Execute PR command when capture function has finished.	After first position is captured, the system will enable the compare function	After first position is captured, the position will be reset.	Start capture function
Explanation	After capture function has finished, execute PR # 50 command.	The compare function is enabled already, and this setting will become ineffective.	When the first point is captured, the position coordinate will be reset.	Setting Bit0 to 1 will enable the capture function. When capture function has finished, the value of Bit0 will be reset to 0 automatically.

Bit0: When the value of P5-38 is higher than 0, setting Bit0 to 1 will enable the capture function and the DO signal, CAP_OK is inactivated. Once the capture function is enabled, everytime when one position is captured, the setting value of P5-38 will decrease 1. When the setting value of P5-38 is equal to 0, it indicates that the capture operation has finished. Then, DO signal, CAP_OK will be activated and the value of Bit0 will be reset to 0 automatically.

When the value of P5-38 is equal to 0, setting Bit0 to 1 will not enable the capture function, the DO signal, CAP_OK will be inactivated and then the value of Bit0 will be reset to 0 automatically. If Bit0 is set to 1 already, the new setting value cannot be 1. The users only can set Bit0 to 0 to disable the capture function.

Bit1: When Bit1 is set to 1, after first position is captured, the system will set the value of the current position as the value of the parameter P5-76.

Bit2: When Bit2 is set to 1, after first position is captured, the system will enable the compare function (Bit0 of P5-59 is set to 1 and the value of P5-58 is set to the last compare amount). If the compare function is enabled already, this setting will become ineffective.

Bit3: When Bit3 is set to 1, after capture operation is completed (all positions has been captured), the position command P50 will be triggered immediately.

B: Capture source settings

- 0: Capture function is disabled.
- 1: Auxiliary encoder (linear scale).
- 2: Pulse command.
- 3: Motor encoder

C: Activate state settings

- 0: Normally open (use N.O. contact)
- 1: Normally closed (use N.C. contact)

D: Trigger time settings (unit: msec)

Chapter 8 Servo Parameters**ASDA-A2**

P5 - 40	DLY0	Delay Time 0	Address: 0550H, 0551H
	Default: 0		Related Section:
	Applicable Control Mode: PR		Section 7.10
	Unit: msec		
	Range: 0 ~ 32767		
	Data Size: 16-bit		
	Display Format: Decimal		
P5 - 41	DLY1	Delay Time 1	Address: 0552H, 0553H
	Default: 100		Related Section:
	Applicable Control Mode: PR		Section 7.10
	Unit: msec		
	Range: 0 ~ 32767		
	Data Size: 16-bit		
	Display Format: Decimal		
P5 - 42	DLY2	Delay Time 2	Address: 0554H, 0555H
	Default: 200		Related Section:
	Applicable Control Mode: PR		Section 7.10
	Unit: msec		
	Range: 0 ~ 32767		
	Data Size: 16-bit		
	Display Format: Decimal		
P5 - 43	DLY3	Delay Time 3	Address: 0556H, 0557H
	Default: 400		Related Section:
	Applicable Control Mode: PR		Section 7.10
	Unit: msec		
	Range: 0 ~ 32767		
	Data Size: 16-bit		
	Display Format: Decimal		

ASDA-A2**Chapter 8 Servo Parameters**

P5 - 44	DLY4	Delay Time 4	Address: 0558H, 0559H
----------------	-------------	---------------------	------------------------------

Default: 500

Related Section:

Applicable Control Mode: PR

Section 7.10

Unit: msec

Range: 0 ~ 32767

Data Size: 16-bit

Display Format: Decimal

P5 - 45	DLY5	Delay Time 5	Address: 055AH, 055BH
----------------	-------------	---------------------	------------------------------

Default: 800

Related Section:

Applicable Control Mode: PR

Section 7.10

Unit: msec

Range: 0 ~ 32767

Data Size: 16-bit

Display Format: Decimal

P5 - 46	DLY6	Delay Time 6	Address: 055CH, 055DH
----------------	-------------	---------------------	------------------------------

Default: 1000

Related Section:

Applicable Control Mode: PR

Section 7.10

Unit: msec

Range: 0 ~ 32767

Data Size: 16-bit

Display Format: Decimal

P5 - 47	DLY7	Delay Time 7	Address: 055EH, 055FH
----------------	-------------	---------------------	------------------------------

Default: 1500

Related Section:

Applicable Control Mode: PR

Section 7.10

Unit: msec

Range: 0 ~ 32767

Data Size: 16-bit

Display Format: Decimal

Chapter 8 Servo Parameters**ASDA-A2**

P5 - 48	DLY8	Delay Time 8	Address: 0560H, 0561H
----------------	-------------	---------------------	------------------------------

Default: 2000

Related Section:

Applicable Control Mode: PR

Section 7.10

Unit: msec

Range: 0 ~ 32767

Data Size: 16-bit

Display Format: Decimal

P5 - 49	DLY9	Delay Time 9	Address: 0562H, 0563H
----------------	-------------	---------------------	------------------------------

Default: 2500

Related Section:

Applicable Control Mode: PR

Section 7.10

Unit: msec

Range: 0 ~ 32767

Data Size: 16-bit

Display Format: Decimal

P5 - 50	DLY10	Delay Time 10	Address: 0564H, 0565H
----------------	--------------	----------------------	------------------------------

Default: 3000

Related Section:

Applicable Control Mode: PR

Section 7.10

Unit: msec

Range: 0 ~ 32767

Data Size: 16-bit

Display Format: Decimal

P5 - 51	DLY11	Delay Time 11	Address: 0566H, 0567H
----------------	--------------	----------------------	------------------------------

Default: 3500

Related Section:

Applicable Control Mode: PR

Section 7.10

Unit: msec

Range: 0 ~ 32767

Data Size: 16-bit

Display Format: Decimal

ASDA-A2**Chapter 8 Servo Parameters**

P5 - 52	DLY12	Delay Time 12	Address: 0568H, 0569H
----------------	--------------	----------------------	------------------------------

Default: 4000

Related Section:

Applicable Control Mode: PR

Section 7.10

Unit: msec

Range: 0 ~ 32767

Data Size: 16-bit

Display Format: Decimal

P5 - 53	DLY13	Delay Time 13	Address: 056AH, 056BH
----------------	--------------	----------------------	------------------------------

Default: 4500

Related Section:

Applicable Control Mode: PR

Section 7.10

Unit: msec

Range: 0 ~ 32767

Data Size: 16-bit

Display Format: Decimal

P5 - 54	DLY14	Delay Time 14	Address: 056CH, 056DH
----------------	--------------	----------------------	------------------------------

Default: 5000

Related Section:

Applicable Control Mode: PR

Section 7.10

Unit: msec

Range: 0 ~ 32767

Data Size: 16-bit

Display Format: Decimal

P5 - 55	DLY15	Delay Time 15	Address: 056EH, 056FH
----------------	--------------	----------------------	------------------------------

Default: 5500

Related Section:

Applicable Control Mode: PR

Section 7.10

Unit: msec

Range: 0 ~ 32767

Data Size: 16-bit

Display Format: Decimal

P5 - 56	CMST	COMPARE: Start Address of Data Array	Address: 0570H, 0571H
Default: 0		Related Section:	
Applicable Control Mode: ALL		Section 7.11.2	
Unit: N/A			
Range: 0 ~ (P5-10-1)			
Data Size: 16-bit			
Display Format: Decimal			
Settings:			
This parameter is used to specify the start address which compares the first point data and save it into data array.			
Please note:			
This parameter can be set only when COMPARE function is disabled (Refer to P5-59).			

P5 - 57	CMAX	COMPARE: Axis Position	Address: 0572H, 0573H
Default: 0		Related Section:	
Applicable Control Mode: ALL		Section 7.11.2	
Unit: N/A			
Range: -2147483648 ~ +2147483647			
Data Size: 32-bit			
Display Format: Decimal			
Settings:			
This parameter can be set only when COMPARE function is disabled (Refer to P5-59).			
Please note:			
<ol style="list-style-type: none"> 1. Do not change this parameter when the compare source is the capture axis and motor encoder. 2. The pulse resolution is determined by the parameter P1-46. 3. When the setting value B of the parameter P5-59 is set to 3, i.e. the compare source is the motor encoder, the value of this parameter is reset to the motor encoder feedback position (monitor variable is 00h). If the motor encoder feedback position is different from this parameter because homing operation is enabled or the capture function setting is changed, the users can set the setting value B of P5-59 to 3 to make this parameter to be equivalent to the motor encoder feedback position. 			

ASDA-A2**Chapter 8 Servo Parameters**

P5 - 58	CMNO	COMPARE: Compare Amount	Address: 0574H, 0575H
----------------	-------------	--------------------------------	------------------------------

Default: 1

Related Section:

Applicable Control Mode: ALL

Section 7.11.2

Unit: N/A

Range: 1 ~ (P5-10 - P5-56)

Data Size: 16-bit

Display Format: Decimal

Settings:

When the compare function is not enabled, using this parameter can set the estimated compare amount (able to read and write).

When the compare function is enabled, using this parameter can set the rest compare amount (read-only). When the setting value of P5-58 is equal to 0, it indicates that the compare operation has finished.

Please note:

The total amount of COMPARE, CAPTURE and E-Cam data can not exceed the number of 800.

P5 - 59	CMCT	COMPARE: Compare Source Setting	Address: 0576H, 0577H
----------------	-------------	--	------------------------------

Default: 00640010h

Related Section:

Applicable Control Mode: ALL

Section 7.11.2

Unit: N/A

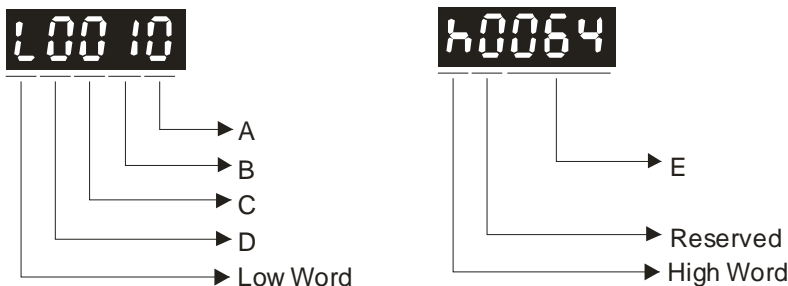
Range: 00010000h ~ 0FFF3137h

Data Size: 32-bit

Display Format: Hexadecimal

Settings:

This parameter is used to determine the compare source and enable the compare function.



A: Compare function settings:

Bit	3	2	1	0
Function	-	After the last position is compared, the system will enable the capture function	Cycle mode	Start compare function
Explanation	-	The capture function is enabled already, and this setting will become ineffective.	The compare operation will not stop.	Setting Bit0 to 1 will enable the compare function. When compare function has finished, the value of Bit0 will be reset to 0 automatically.

Bit0: When the value of P5-58 is higher than 0, setting Bit0 to 1 will enable the compare function. Once the compare function is enabled, everytime when one position is compared, the setting value of P5-58 will decrease 1. When the setting value of P5-58 is equal to 0, it indicates that the compare operation has finished and the value of Bit0 will be reset to 0 automatically.

When the value of P5-58 is equal to 0, setting Bit0 to 1 will not enable the compare function, and then the value of Bit0 will be reset to 0 automatically. If Bit0 is set to 1 already, the new setting value cannot be 1. The users only can set Bit0 to 0 to disable the compare function.

Bit1: When Bit1 is set to 1, after the last position is compared, the setting value of P5-58 will be reset and start the compare operation from the first position again. The compare operation will not stop and the value of Bit0 will be retained as 1.

Bit2: When Bit2 is set to 1, after the last position is compared, the system will enable the capture function (Bit0 of P5-39 is set to 1 and the value of P5-38 is set to the last capture amount). If the capture function is enabled already, this setting will become ineffective.

Bit3: Reserved.

B: Compare source settings

0: Capture axis.

1: Auxiliary encoder (linear scale).

2: Pulse command.

3: Motor encoder

C: Activate state settings

0: Normally open (use N.O. contact)

1: Normally closed (use N.C. contact)

E: Length of output pulse (unit: 1 msec)

ASDA-A2**Chapter 8 Servo Parameters**

P5 - 60	POV0	Moving Speed Setting of Position 0	Address: 0578H, 0579H
Default: 20.0		Related Section:	
Applicable Control Mode: PR		Section 7.10	
Unit: 0.1 r/min			
Range: 0.1 ~ 6000.0			
Data Size: 16-bit			
Display Format: Decimal			
P5 - 61	POV1	Moving Speed Setting of Position 1	Address: 057AH, 057BH
Default: 50.0		Related Section:	
Applicable Control Mode: PR		Section 7.10	
Unit: 0.1 r/min			
Range: 0.1 ~ 6000.0			
Data Size: 16-bit			
Display Format: Decimal			
P5 - 62	POV2	Moving Speed Setting of Position 2	Address: 057CH, 057DH
Default: 100.0		Related Section:	
Applicable Control Mode: PR		Section 7.10	
Unit: 0.1 r/min			
Range: 0.1 ~ 6000.0			
Data Size: 16-bit			
Display Format: Decimal			
P5 - 63	POV3	Moving Speed Setting of Position 3	Address: 057EH, 057FH
Default: 200.0		Related Section:	
Applicable Control Mode: PR		Section 7.10	
Unit: 0.1 r/min			
Range: 0.1 ~ 6000.0			
Data Size: 16-bit			
Display Format: Decimal			

Chapter 8 Servo Parameters**ASDA-A2**

P5 - 64	POV4	Moving Speed Setting of Position 4	Address: 0580H, 0581H
----------------	-------------	---	------------------------------

Default: 300.0

Related Section:

Applicable Control Mode: PR

Section 7.10

Unit: 0.1 r/min

Range: 0.1 ~ 6000.0

Data Size: 16-bit

Display Format: Decimal

P5 - 65	POV5	Moving Speed Setting of Position 5	Address: 0582H, 0583H
----------------	-------------	---	------------------------------

Default: 500.0

Related Section:

Applicable Control Mode: PR

Section 7.10

Unit: 0.1 r/min

Range: 0.1 ~ 6000.0

Data Size: 16-bit

Display Format: Decimal

P5 - 66	POV6	Moving Speed Setting of Position 6	Address: 0584H, 0585H
----------------	-------------	---	------------------------------

Default: 600.0

Related Section:

Applicable Control Mode: PR

Section 7.10

Unit: 0.1 r/min

Range: 0.1 ~ 6000.0

Data Size: 16-bit

Display Format: Decimal

P5 - 67	POV7	Moving Speed Setting of Position 7	Address: 0586H, 0587H
----------------	-------------	---	------------------------------

Default: 800.0

Related Section:

Applicable Control Mode: PR

Section 7.10

Unit: 0.1 r/min

Range: 0.1 ~ 6000.0

Data Size: 16-bit

Display Format: Decimal

ASDA-A2**Chapter 8 Servo Parameters**

P5 - 68	POV8	Moving Speed Setting of Position 8	Address: 0588H, 0589H
Default: 1000.0		Related Section:	
Applicable Control Mode: PR		Section 7.10	
Unit: 0.1 r/min			
Range: 0.1 ~ 6000.0			
Data Size: 16-bit			
Display Format: Decimal			
P5 - 69	POV9	Moving Speed Setting of Position 9	Address: 058AH, 058BH
Default: 1300.0		Related Section:	
Applicable Control Mode: PR		Section 7.10	
Unit: 0.1 r/min			
Range: 0.1 ~ 6000.0			
Data Size: 16-bit			
Display Format: Decimal			
P5 - 70	POV10	Moving Speed Setting of Position 10	Address: 058CH, 058DH
Default: 1500.0		Related Section:	
Applicable Control Mode: PR		Section 7.10	
Unit: 0.1 r/min			
Range: 0.1 ~ 6000.0			
Data Size: 16-bit			
Display Format: Decimal			
P5 - 71	POV11	Moving Speed Setting of Position 11	Address: 058EH, 058FH
Default: 1800.0		Related Section:	
Applicable Control Mode: PR		Section 7.10	
Unit: 0.1 r/min			
Range: 0.1 ~ 6000.0			
Data Size: 16-bit			
Display Format: Decimal			

Chapter 8 Servo Parameters**ASDA-A2**

P5 - 72	POV12	Moving Speed Setting of Position 12	Address: 0590H, 0591H
----------------	--------------	--	------------------------------

Default: 2000.0

Related Section:

Applicable Control Mode: PR

Section 7.10

Unit: 0.1 r/min

Range: 0.1 ~ 6000.0

Data Size: 16-bit

Display Format: Decimal

P5 - 73	POV13	Moving Speed Setting of Position 13	Address: 0592H, 0593H
----------------	--------------	--	------------------------------

Default: 2300.0

Related Section:

Applicable Control Mode: PR

Section 7.10

Unit: 0.1 r/min

Range: 0.1 ~ 6000.0

Data Size: 16-bit

Display Format: Decimal

P5 - 74	POV14	Moving Speed Setting of Position 14	Address: 0594H, 0595H
----------------	--------------	--	------------------------------

Default: 2500.0

Related Section:

Applicable Control Mode: PR

Section 7.10

Unit: 0.1 r/min

Range: 0.1 ~ 6000.0

Data Size: 16-bit

Display Format: Decimal

P5 - 75	POV15	Moving Speed Setting of Position 15	Address: 0596H, 0597H
----------------	--------------	--	------------------------------

Default: 3000.0

Related Section:

Applicable Control Mode: PR

Section 7.10

Unit: 0.1 r/min

Range: 0.1 ~ 6000.0

Data Size: 16-bit

Display Format: Decimal

ASDA-A2**Chapter 8 Servo Parameters**

P5 - 76★	CPRS	Capture 1st Position Reset Data	Address: 0598H, 0599H
-----------------	-------------	--	------------------------------

Default: 0

Related Section:

Applicable Control Mode: ALL

Section 7.10

Unit: N/A

Range: -1073741824 ~ +1073741823

Data Size: 32-bit

Display Format: Decimal

Settings:

Refer to P5-39 for explanation.

P5 - 77■	CSAX	Position of CAPTURE SYNC AXIS	Address: 059AH, 059BH
-----------------	-------------	--------------------------------------	------------------------------

Default: 0

Related Section: N/A

Applicable Control Mode: ALL

Unit: N/A

Range: -2147483648 ~ +2147483647

Data Size: 32-bit

Display Format: Decimal

Settings:

This position will be synchronized with the capture signal. When capture operation is activated every two times, the offset value of this SYNC axis will be equal to the value of P5-78 (no accumulation errors, for single direction operation only).

This parameter can be used as the position source of E-Cam master axis.

Please note:

ASDA-A2 series L type models does not provide Electronic Cam (E-Cam) function.

P5 - 78	CSDS	Interval Pulse Number of CAPTURE SYNC AXIS	Address: 059CH, 059DH
----------------	-------------	---	------------------------------

Default: 100

Related Section: N/A

Applicable Control Mode: ALL

Unit: pulse

Range: 10 ~ +100000000

Data Size: 32-bit

Display Format: Decimal

Settings:

This parameter is used to set the offset value of this SYNC axis when capture operation is activated every two times.

Please note:

This parameter can be set only when capture operation is stopped (Refer to P5-39).

P5 - 79	CSDS	Error Pulse Number of CAPTURE SYNC AXIS	Address: 059EH, 059FH
----------------	-------------	--	------------------------------

Default: 0

Related Section: N/A

Applicable Control Mode: ALL

Unit: pulse

Range: -2147483648 ~ +2147483647

Data Size: 32-bit

Display Format: Decimal

Settings:

This parameter is used to display the error pulse number of CAPTURE SYNC AXIS operation.

SYNC error pulse number = output value of SYNC axis - ideal value of SYNC axis
 = P5-77 accumulation amount - (P5-78 x capture times)

When SYNC axis operates after the data is captured, the system will update this parameter once.

This parameter can be set to indicate the offset amount of specified SYNC axis. When the servo system is regarded as the master axis for rotary cutoff application, modifying this parameter is able to shift the cutoff position to left or right every time.

P5 - 80	CSDS	Max. Correction Rate of CAPTURE SYNC AXIS	Address: 05A0H, 05A1H
----------------	-------------	--	------------------------------

Default: 10

Related Section: N/A

Applicable Control Mode: ALL

Unit: %

Range: 1 ~ 90

Data Size: 16-bit

Display Format: Decimal

Settings:

This parameter is used to limit the correction rate of CAPTURE SYNC AXIS.

Correction rate = output pulses of SYNC axis - input pulses of SYNC axis
 (100 - P5-80)% < Correction Rate < (100 + P5-80)%

When the value of the correction rate is higher, the SYNC error value will go towards 0 quickly, i.e. attain the desired position more easily, but the changes of the speed are very fast.

When the value of the correction rate is lower, the SYNC error value will go towards 0 slowly, i.e. attain the desired position more difficultly, but the changes of the speed are very smooth.

For rotary cutoff application, after adjusting P5-79, if the setting value of P5-80 is higher, the system can attain the desired rotary cutoff position quickly but the desired speed can not be easily reached.

ASDA-A2**Chapter 8 Servo Parameters**

P5 - 81	ECHD	E-Cam: Start Address of Data Array	Address: 05A2H, 05A3H
----------------	-------------	---	------------------------------

Default: 100

Related Section:

Applicable Control Mode: PR

Section 7.11

Unit: N/A

Range: 0 ~ (800 - P5-82)

Data Size: 16-bit

Display Format: Decimal

Settings:

This parameter is used to set the start address which specifies the first point data of E-Cam table and save it into data array.

Please note:

1. The firmware version V1.015 and earlier models:
This parameter can not be changed when E-Cam function is enabled (Refer to P5-88).
2. The firmware version V1.015 and later models:
This parameter can be set any time. However, it is effective only when the electronic gear is engaged.
3. ASDA-A2 series L type models does not provide Electronic Cam (E-Cam) function.

P5 - 82	ECHN	E-Cam: E-Cam Area Number N (at least >=5)	Address: 05A4H, 05A5H
----------------	-------------	---	------------------------------

Default: 5

Related Section:

Applicable Control Mode: PR

Section 7.11

Unit: N/A

Range: 5 ~ 720, must be $\leq (P5-10 - P5-81)$ and $(P5-82 \times P5-84) \leq 2147483647$

Data Size: 16-bit

Display Format: Decimal

Settings:

The E-Cam graph is divided into N areas. The E-Cam table should include N+1 data.

Please note:

1. This parameter can be set only when E-Cam function is stopped (Refer to P5-88).
2. ASDA-A2 series L type models does not provide Electronic Cam (E-Cam) function.

P5 - 83	ECMM	E-Cam: E-Cam Cycle Number (M)	Address: 05A6H, 05A7H
----------------	-------------	--------------------------------------	------------------------------

Default: 1

Related Section:

Applicable Control Mode: PR

Section 7.11

Unit: N/A

Range: 1 ~ 32767

Data Size: 16-bit

Display Format: Decimal

Settings:

After receiving the pulse number P of master axis, the shaft of E-Cam will rotate M cycles. It indicates that there are M cycles of the E-Cam table.

Please note:

1. This parameter can be set only when E-Cam function is stopped (Refer to P5-88).
2. ASDA-A2 series L type models does not provide Electronic Cam (E-Cam) function.

P5 - 84

ECMP	E-Cam: Pulse Number of Master Axis (P)	Address: 05A8H, 05A9H
-------------	---	------------------------------

Default: 3600

Related Section:

Applicable Control Mode: PR

Section 7.11

Unit: N/A

Range: 10 ~ 1073741823, (P5-82 x P5-83) ≤ P5-84 and (P5-82 x P5-84) ≤ 2147483647

Data Size: 32-bit

Display Format: Decimal

Settings:

After receiving the pulse number P of master axis, the shaft of E-Cam will rotate M cycles. It indicates that there are M cycles of the E-Cam table.

Please note:

1. This parameter can be set only when E-Cam function is stopped (Refer to P5-88).
2. The firmware version V1.018 and later models: This parameter can be set any time.
3. ASDA-A2 series L type models does not provide Electronic Cam (E-Cam) function.

P5 - 85

ECME	E-Cam: Engage Area Number	Address: 05AAH, 05ABH
-------------	----------------------------------	------------------------------

Default: 0

Related Section:

Applicable Control Mode: PR

Section 7.11

Unit: N/A

Range: 0 ~ (P5-82 -1)

Data Size: 16-bit

Display Format: Decimal

Settings:

This parameter is used to set the E-Cam area number when the electronic gear is engaged.

Please note:

ASDA-A2 series L type models does not provide Electronic Cam (E-Cam) function.

ASDA-A2**Chapter 8 Servo Parameters**

P5 - 86	ECAX	E-Cam: Position of Master Axis	Address: 05ACH, 05ADH
----------------	-------------	---------------------------------------	------------------------------

Default: 0

Related Section:

Applicable Control Mode: PR

Section 7.11

Unit: N/A

Range: -2147483648 ~ +2147483647

Data Size: 32-bit

Display Format: Decimal

Settings:

This parameter is used to set the position of E-Cam master axis.

Please note:

1. This parameter can be set only when E-Cam function is stopped (Refer to P5-88).
2. ASDA-A2 series L type models does not provide Electronic Cam (E-Cam) function.

P5 - 87	PLED	E-Cam: Lead Command Length	Address: 05AEH, 05AFH
----------------	-------------	-----------------------------------	------------------------------

Default: 0

Related Section:

Applicable Control Mode: PR

Section 7.11

Unit: N/A

Range: -1073741824 ~ +1073741823

Data Size: 32-bit

Display Format: Decimal

Settings:

This parameter is used to set the length of the lead command before the electronic gear is engaged. Once E-Cam engage conditions are satisfied (see the Z settings of P5-88), the electronic gear will be engaged truly when the pulse number sent by master axis is higher than the setting value of P5-87. In other words, the electronic gear will be engaged only after the lead command specified by P5-87 is ignored.

Please note:

1. If this parameter is a positive value, it indicates that the forward pulses are regarded as lead command. If this parameter is a negative value, it indicates that the reverse pulses are regarded as lead command.
2. ASDA-A2 series L type models does not provide Electronic Cam (E-Cam) function.

P5 - 88	ECON	E-Cam: E-Cam Settings	Address: 05B0H, 05B1H
----------------	-------------	------------------------------	------------------------------

Default: 00000000h

Related Section:

Applicable Control Mode: PR

Section 7.11

Unit: N/A

Range: 0 ~ 203FF251h

Data Size: 32-bit

Display Format: Hexiadecimal

Settings:

Display	High Word			Low Word			
	S	O	BA	U	Z	Y	X
Range	0 ~ 2	-	00 ~ 3F	0 ~ 8	0 ~ 2	0 ~ 5	0 ~ 1

X: Disable or Enable E-Cam Command

0: Disable E-Cam

1: Enable E-Cam

Y: Sources of Master Axis

0: Capture Axis

1: Linear encoder

2: Pulse command

3. PR command

4. Time axis (1msec)

5: Capture Sync. Axis (P5-77)

Z: Engage timing (only one option can be selected)

0: Immediately

1: DI signal: CAM ON

2. Any point of Capture Axis

U: Disengage timing (the setting value can be added up, but the setting value 2, 4 and 6 can not be selected simultaneously.)

U	Disengage Conditions	State after the electronic gear is disengaged.
0	Do not disengage	-
1	DI signal: CAM OFF	Enter into the state of Stop
2	Master axis reaches the setting value of P5-89. (The polarity sign indicates the direction)	Enter into the state of Stop
6	(available in firmware V1.009 and later models) The function is the same as the function of U=2, but the differences are that the speed will not change when electronic gear is disengaged and the engage length will exceed the setting value of P5-89 a little. This option is suitable for the application which needs to use PR command immediately after the electronic gear is disengaged.	
4	(available in firmware V1.009 and later models) Master axis exceeds the setting value of P5-89. (The polarity sign indicates the direction)	Return to the Lead state (before the electronic gear is engaged) (The lead command length is set by P5-92).
8	Disable E-Cam function after the electronic gear is disengaged.	Set X=0

When Servo Off, if a servo fault occurs, or there is a forward/reverse limit, or PR command is moving to home, the electronic gear will be disengaged (X=0 of P5-88).

BA: Disengage method. The setting value is 00 ~ 3F (00: Disabled).

When the disengage conditions are satisfied (U= 2, 4 and 6 of P5-88), the system will execute PR path (hexadecimal) automatically

S: Engage status display (read-only)

0: Stop state

1: Engaged state

2: Lead state (before the electronic gear is engaged)

Please note:

ASDA-A2 series L type models does not provide Electronic Cam (E-Cam) function.

P5 - 89	ECRD	E-Cam: Disengage Timing Data	Address: 05B2H, 05B3H
----------------	-------------	-------------------------------------	------------------------------

Default: 0

Related Section:

Applicable Control Mode: PR

Section 7.11

Unit: N/A

Range: -1073741824 ~ +1073741823

Data Size: 32-bit

Display Format: Decimal

Settings:

Refer to the U settings of P5-88 for explanation.

Please note:

ASDA-A2 series L type models does not provide Electronic Cam (E-Cam) function.

P5 - 90	CMAF	E-Cam: Area Number + (Polarity is Positive)	Address: 05B4H, 05B5H
----------------	-------------	--	------------------------------

Default: 0

Related Section:

Applicable Control Mode: PR

Section 7.11

Unit: degree (it becomes degree in firmware version V1.009 and later models)

Range: 0 ~ 360

Data Size: 16-bit

Display Format: Decimal

Please note:

ASDA-A2 series L type models does not provide Electronic Cam (E-Cam) function.

Chapter 8 Servo Parameters

ASDA-A2

P5 - 91	CMAN	E-Cam: Area Number - (Polarity is Negative)	Address: 05B6H, 05B7H
----------------	-------------	--	------------------------------

Default: 0

Related Section:

Applicable Control Mode: PR

Section 7.11

Unit: degree (it becomes degree in firmware version V1.009 and later models)

Range: 0 ~ 360

Data Size: 16-bit

Display Format: Decimal

Please note:

ASDA-A2 series L type models does not provide Electronic Cam (E-Cam) function.

P5 - 92	PLED	E-Cam: Cyclic Lead Command Length	Address: 05B8H, 05B9H
----------------	-------------	--	------------------------------

Default: 0

Related Section:

Applicable Control Mode: PR

Section 7.11

Unit: N/A

Range: -100000000 ~ +100000000

Data Size: 32-bit

Display Format: Decimal

Settings: (available in firmware version V1.006 sub04 and later models only)

This parameter works in conjunction with the function of U=4 set in parameter P5-88.

When the electronic gear is disengaged, it will not enter into Stop state. It will enter into the lead state (before the electronic gear is engaged) and the lead command length at this time is determined by the setting of P5-92.

The electronic gear will be engaged again when the pulse number sent by master axis is higher than the setting value of P5-92. In other words, the electronic gear will be engaged only after the lead command specified by P5-92 is ignored.

Please note:

1. If this parameter is a positive value, it indicates that the forward pulses are regarded as lead command. If this parameter is a negative value, it indicates that the reverse pulses are regarded as lead command.
2. ASDA-A2 series L type models does not provide Electronic Cam (E-Cam) function.

P5 - 93	CSDS	Motion Control: Macro Parameter 4	Address: 05BAH, 05BBH
----------------	-------------	--	------------------------------

Default: 0

Related Section: N/A

Applicable Control Mode: ALL

Unit: N/A

Range: -2147483648 ~ +2147483647

Data Size: 32-bit

Display Format: Decimal

Settings:

The definition of this parameter is determined by macro command P5-97. Please refer to P5-97 for explanation.

P5 - 94	CSDS	Motion Control: Macro Parameter 3	Address: 05BCH, 05BDH
----------------	-------------	--	------------------------------

Default: 0

Related Section: N/A

Applicable Control Mode: ALL

Unit: N/A

Range: -2147483648 ~ +2147483647

Data Size: 32-bit

Display Format: Decimal

Settings:

The definition of this parameter is determined by macro command P5-97. Please refer to P5-97 for explanation.

P5 - 95	CSDS	Motion Control: Macro Parameter 2	Address: 05BEH, 05BFH
----------------	-------------	--	------------------------------

Default: 0

Related Section: N/A

Applicable Control Mode: ALL

Unit: N/A

Range: -2147483648 ~ +2147483647

Data Size: 32-bit

Display Format: Decimal

Settings:

The definition of this parameter is determined by macro command P5-97. Please refer to P5-97 for explanation.

P5 - 96	CSDS	Motion Control: Macro Parameter 1	Address: 05C0H, 05C1H
----------------	-------------	--	------------------------------

Default: 0

Related Section: N/A

Applicable Control Mode: ALL

Unit: N/A

Range: -2147483648 ~ +2147483647

Data Size: 32-bit

Display Format: Decimal

Settings:

The definition of this parameter is determined by macro command P5-97. Please refer to P5-97 for explanation.

P5 - 97	CSDS	Motion Control: Macro Command	Address: 05C2H, 05C3H
----------------	-------------	--------------------------------------	------------------------------

Default: 100

Related Section: N/A

Applicable Control Mode: ALL

Unit: pulse

Range: 0 ~ 0999h

Data Size: 16-bit

Display Format: Hexadecimal

Settings:

Write function: This parameter can be used to set macro command (0CBAh)

Read function: This parameter can be used to display the execution result of macro command (If the command has succeeded, 1CBAh will be sent back).

When the macro command code is set to 0001, if the command has succeeded, 1001h will be sent back. If the command has failed, Fxxxh will be sent back.

When setting illegal command code, the failure code, Fxxxh will be sent back also.

The legal commands are listed in the table below:

Command code: 0000h	Disable CAPTURE SYNC AXIS
Parameters	N/A
<p>After this marco command is executed, the position of CAPTURE SYNC AXIS (P5-77) will not perform synchronization correction.</p> <p>The capture and compare function will be disabled at the same time.</p> <p>The capture source settings will not be set to 0. The capture source settings can be changed.</p>	
Failure code: F002h	The compare function cannot be disabled.

Command code: 0001h	Enable CAPTURE SYNC AXIS
Parameters	<p>P5-96: Compare the coordinate of the first point.</p> <p>P5-39: Set U, Z, Y settings by referring the user manual. There is no need to set X settings.</p> <p>P5-59: Set CBA, Z setting by referring the user manual. There is no need to set X and Y settings.</p> <p>P5-78: Set the offset value of SYNC axis when capture operation is activated every two times.</p>
<p>Please set the relevant parameters above in advance and then execute this macro command.</p> <p>After this marco command is executed, the position of CAPTURE SYNC AXIS (P5-77) will start to perform synchronization correction.</p> <p>The capture and compare function will be enabled at the same time.</p>	
Failure code: F002h	The capture function is enabled. Please disable it.
Failure code: F003h	The compare function is enabled. Please disable it.
Failure code: F004h	The address of capture and compare data array is the same address.

The firmware version V1.018 and later models provide the following macro command:

Command code: 0005h	Set the pulse number when the electronic gear is disengaged after one E-Cam cycle (360 degrees).
Parameters	P5-95: Pulse number of master axis for one E-Cam cycle
Please set P5-84=P5-89<=P5-85 and set P5-83=1 simultaneously. It indicates that the setting value of P5-95 will display the pulse number for one E-Cam cycle, i.e. the pulse number when the electronic gear is disengaged automatically. (This setting needs to work in conjunction with P5-88 (U=2, 4, 6).	
Failure code: F005h	The setting value of P5-95 has exceeded the specification of P5-84.

The firmware version V1.024 and later models provide the following macro command:

Command code: 0006h	Create E-Cam table: for rotary cutoff application (7 areas)
General Parameters	P5-81: Start Address of Data Array for E-Cam table. P5-82: E-Cam Area Number. Set P5-82 to 7 (7 areas, 8 points). P1-44, P1-45: Electronic Gear Ratio (must be set first)
Macro Parameters	P5-94=A (Deceleration Ratio: Numerator) x C (Knife Number) P5-95=B (Deceleration Ratio: Denominator) P5-96= 1000000 x R x V R (Cut Ratio) = L (Cut Length) x C (Knife Number) x \square (Knife Circumference) The normal cut ratio is the multiple of 0.3 ~ 2.5. V (Speed Compensation) = (Cut Speed) / (Product Speed) When V=1.0, the speed of knife is the same as the product during cutting operation. When V=1.1, the speed of knife will be increased 10% When V=0.9, the speed of knife will be decreased 10% and so on.
Using this macro command is able to calculate the data of E-Cam table and saved the settings in the data array specified by P5-81. The above parameters are all essential for E-Cam table. Please complete the settings of these parameters first correctly before executing this macro command.	

After this macro command is executed, if the settings of the above parameters are changed, please execute this macro command again so as to create the new E-Cam table again.

The data of E-Cam table will be changed after executing this macro command, therefore, do not to execute this macro command when the electronic gear is engaged.

When the execution of this macro command is completed, the data of E-Cam table will not be memorized in EEPROM automatically.

There are many E-Cam parameters, such as P5-83 and P5-84, etc. which are not used for this macro commands.

For more E-Cam parameters and functions, please refer to Chapter 7.

Failure code: F061h	The electronic gear is engaged when creating E-Cam table.
---------------------	---

Chapter 8 Servo Parameters

ASDA-A2

Failure code: F062h	The setting value of P5-94 has exceeded the specification (1 ~ 65535)
Failure code: F063h	The setting value of P5-95 has exceeded the specification (1 ~ 65535)
Failure code: F064h	The setting value of P5-96 has exceeded the specification (300000 ~ 2500000)
Failure code: F065h	The address specified by P5-81 is too big. The space of the data array is not sufficient.
Failure code: F066h	The setting value of P5-82 should be set to 7; otherwise this macro command can not be executed.
Failure code: F067h	Data calculation error. Please decrease the setting value of P1-44 and P1-45.

Please note:

ASDA-A2 series L type models does not provide Electronic Cam (E-Cam) function.

P5 - 98	EVON	Event Rising-edge Trigger Command (OFF → ON)	Address: 05C4H, 05C5H

Default: 0

Related Section: N/A

Applicable Control Mode: PR

Unit: N/A

Range: 0000 ~ DDDDh

Data Size: 16-bit

Display Format: Hexadecimal

Settings:

This parameter is used to trigger the position command when DI signals, EV1 ~ EV4 (Event trigger command 1 ~ 4) are ON (activated).

Display	U	Z	Y	X
Range	0 ~ D	0 ~ D	0 ~ D	0 ~ D

X: EV1 settings

0: When EV1 is ON, no position command is triggered.

1 ~ D: When EV1 is ON, position command P51 ~ P63 is triggered.

For example, when the setting value of X is set to 1 while EV1 is ON, the position command P51 is triggered. When the setting value of X is set to 2, the position command P52 is triggered, and so on.

Y: EV2 settings

0: When EV2 is ON, no position command is triggered.

1 ~ D: When EV2 is ON, position command P51 ~ P63 is triggered.

Please note:

The DI signals, EV3 and EV4 are available for the firmware version V1.009 and later models.

Z: EV3 settings

0: When EV3 is ON, no position command is triggered.

1 ~ D: When EV3 is ON, position command P51 ~ P63 is triggered.

U: EV4 settings

0: When EV4 is ON, no position command is triggered.

1 ~ D: When EV4 is ON, position command P51 ~ P63 is triggered.

P5 - 99

EVOF	Event Falling-edge Trigger Command (ON → OFF)	Address: 05C6H, 05C7H
-------------	--	------------------------------

Default: 0

Related Section: N/A

Applicable Control Mode: PR

Unit: N/A

Range: 0000 ~ DDDHh

Data Size: 16-bit

Display Format: Hexadecimal

Settings:

This parameter is used to trigger the position command when DI signal, EV1 ~ EV4 (Event trigger command 1 ~ 4) are OFF (inactivated).

Display	U	Z	Y	X
Range	0 ~ D	0 ~ D	0 ~ D	0 ~ D

X: EV1 settings

0: When EV1 is OFF, no position command is triggered.

1 ~ D: When EV1 is OFF, position command P51 ~ P63 is triggered.

For example, when the setting value of X is set to 1 while EV1 is OFF, the position command P51 is triggered. When the setting value of X is set to 2, the position command P52 is triggered, and so on.

Y: EV2 settings

0: When EV2 is OFF, no position command is triggered.

1 ~ D: When EV2 is OFF, position command P51 ~ P63 is triggered.

Please note:

The DI signals, EV3 and EV4 are available for the firmware version V1.009 and later models.

Z: EV3 settings

0: When EV3 is OFF, no position command is triggered.

1 ~ D: When EV3 is OFF, position command P51 ~ P63 is triggered.

U: EV4 settings

0: When EV4 is OFF, no position command is triggered.

1 ~ D: When EV4 is OFF, position command P51 ~ P63 is triggered.

Group 6: P6-xx PR Path Definition Parameters

P6 - 00	ODEF	Homing Definition	Address: 0600H, 0601H
----------------	-------------	--------------------------	------------------------------

Default: 0x00000000

Related Section:

Applicable Control Mode: PR

Section 7.10

Unit: N/A

Range: 0x00000000 ~ 0x10FFFF3F

Data Size: 32-bit

Display Format: Hexadecimal

Settings:

Homing definition:

Bit	31 ~ 28	27 ~ 24	23 ~ 20	19 ~ 16	15 ~ 12	11 ~ 8	7 ~ 4	3 ~ 0
Function	BOOT	-	DLY	DEC2	DEC1	ACC	PATH	

PATH: Path style (4 bits)

0: Stop mode. Motor stops after homing is completed.

1~63: Auto mode. Motor goes the dedicated path after homing is completed.

ACC: Acceleration time 0 ~ F, corresponds to P5-20 ~ P5-35.

DEC1 / DEC2: 1st deceleration time / 2nd deceleration time. Deceleration time 0 ~ F, corresponds to P5-20 ~ P5-35.

DLY: Delay time 0 ~ F, corresponds to P5-40 ~ P5-55.

BOOT: Boot mode. Disable or enable homing function when the servo drive is applied to power (power on).

0: Disable homing function

1: Enable homing function (when the servo drive is applied to power)

Other parameters relevant to homing function:

P5-04 (Homing mode)

P5-05 (1st Speed Setting of High Speed Homing)

P5-06 (2nd Speed Setting of Low Speed Homing)

P6-01: ORG_DEF (Homing definition value). P6-01 is used to set the coordinate value of the current home position for the movement of the coordinate system. The coordinate value could be a non-zero value.

After detecting "Home" (home sensor or Z pulse), the motor will decelerate to stop the operation.

If the motor does not return to "Home", just set path number to 0.

If the motor must return to "Home", set path number to a non-zero value and set the route PABS = ORG_DEF.

When detecting "Home" (home sensor or Z pulse), if the motor has to go forward for a while (offset value S) and reach the position P, set the path number to a non-zero value and set ORG_DEF = P - S (the absolute position command of this route is P).

ASDA-A2**Chapter 8 Servo Parameters**

P6 - 01	ODAT	Homing Definition Value	Address: 0602H, 0603H
----------------	-------------	--------------------------------	------------------------------

Default: 0

Related Section:

Applicable Control Mode: PR

Section 7.10

Unit: N/A

Range: -2147483648 ~ +2147483647

Data Size: 32-bit

Display Format: Decimal

Settings:

Homing definition value:

Bit	31 ~ 28	27 ~ 24	23 ~ 20	19 ~ 16	15 ~ 12	11 ~ 8	7 ~ 4	3 ~ 0
Function	ORG_DEF (32-bit)							

ORG_DEF: Homing definition value which is determined by the parameter P6-01. The homing definition value does not necessarily have to be 0.

P6 - 02	PDEF1	Definition of Path 1	Address: 0604H, 0605H
----------------	--------------	-----------------------------	------------------------------

Default: 0x00000000

Related Section:

Applicable Control Mode: N/A

Section 7.10

Unit: N/A

Range: 0x00000000 ~ 0xFFFFFFFF

Data Size: 32-bit

Display Format: Decimal

Settings:

Bit	31 ~ 28	27 ~ 24	23 ~ 20	19 ~ 16	15 ~ 12	11 ~ 8	7 ~ 4	3 ~ 0
P6-02	-	-	DLY	-	-	-	OPT	TYPE
P6-03	DATA (32-bit)							

TYPE, OPT:

OPT				TYPE
Bit7	Bit6	Bit5	Bit4	Bit3 ~ Bit0
-	UNIT	AUTO	INS	1: Constant speed control
CMD		OVLP	INS	2: Single positioning control. Motor stops when positioning is completed. 3: Auto positioning control. Motor goes to next dedicated path when positioning is completed.
-	-	-	INS	7: Jump to the dedicated path.
-	-	AUTO	INS	8: Write the specified parameter to the dedicated path.

※ When the TYPE is set to 1 ~ 3, it can accept DO signals, STP (Motor Stop), SNL(SCWL, Reverse Software Limit), SPL(SCCWL, Forward Software Limit).

INS: Insertion command on PR.

OVLP: Overlap the next PR. This function is not available in speed mode. In position mode, DLY becomes disabled.

AUTO: When current positioning is completed, the motor moves to the next dedicated PR automatically.

CMD: Refer to Section 7.10 in Chapter 7.

DLY: 0 ~ F. Delay time number (4 bits). The digital output of this PR activates after the delay time. External INS is not valid. The delay time number settings correspond with the parameter P5-40 ~ P5-55.

DLY (4) Index P5-40 ~ P5-55

P6 - 03

PDAT1	Data of Path 1	Address: 0606H, 0607H
--------------	-----------------------	------------------------------

Default: 0

Related Section:

Applicable Control Mode: PR

Section 7.10

Unit: N/A

Range: -2147483648 ~ +2147483647

Data Size: 32-bit

Display Format: Decimal

Settings:

Data of path 1:

Bit	31 ~ 28	27 ~ 24	23 ~ 20	19 ~ 16	15 ~ 12	11 ~ 8	7 ~ 4	3 ~ 0
Function	DATA (32-bit)							

The parameter P6-02 is used to determine the attributes of definition of Path 1 and parameter P6-03 is used to set the data (target position or jump path number) corresponding to P6-02.

P6 - 04

PDEF2	Definition of Path 2	Address: 0608H, 0609H
--------------	-----------------------------	------------------------------

Default: 0x00000000

Related Section:

Applicable Control Mode: PR

Section 7.10

Unit: N/A

Range: 0x00000000 ~ 0xFFFFFFFF

Data Size: 32-bit

Display Format: Decimal

Settings:

Refer to P6-02 for explanation.

ASDA-A2**Chapter 8 Servo Parameters**

P6 - 05	PDAT2	Data of Path 2	Address: 060AH, 060BH
----------------	--------------	-----------------------	------------------------------

Default: 0

Related Section:

Applicable Control Mode: PR

Section 7.10

Unit: N/A

Range: -2147483648 ~ +2147483647

Data Size: 32-bit

Display Format: Decimal

Settings:

Refer to P6-03 for explanation.

P6 - 06	PDEF3	Definition of Path 3	Address: 060CH, 060DH
----------------	--------------	-----------------------------	------------------------------

Default: 0x00000000

Related Section:

Applicable Control Mode: PR

Section 7.10

Unit: N/A

Range: 0x00000000 ~ 0xFFFFFFFF

Data Size: 32-bit

Display Format: Decimal

Settings:

Refer to P6-02 for explanation.

P6 - 07	PDAT3	Data of Path 3	Address: 060EH, 060FH
----------------	--------------	-----------------------	------------------------------

Default: 0

Related Section:

Applicable Control Mode: PR

Section 7.10

Unit: N/A

Range: -2147483648 ~ +2147483647

Data Size: 32-bit

Display Format: Decimal

Settings:

Refer to P6-03 for explanation.

P6 - 08	PDEF4	Definition of Path 4	Address: 0610H, 0611H
----------------	--------------	-----------------------------	------------------------------

Default: 0x00000000

Related Section:

Applicable Control Mode: PR

Section 7.10

Unit: N/A

Range: 0x00000000 ~ 0xFFFFFFFF

Data Size: 32-bit

Chapter 8 Servo Parameters**ASDA-A2**

Display Format: Decimal

Settings:

Refer to P6-02 for explanation.

P6 - 09	PDAT4	Data of Path 4	Address: 0612H, 0613H
----------------	--------------	-----------------------	------------------------------

Default: 0

Related Section:

Applicable Control Mode: PR

Section 7.10

Unit: N/A

Range: -2147483648 ~ +2147483647

Data Size: 32-bit

Display Format: Decimal

Settings:

Refer to P6-03 for explanation.

P6 - 10	PDEF5	Definition of Path 5	Address: 0614H, 0615H
----------------	--------------	-----------------------------	------------------------------

Default: 0x00000000

Related Section:

Applicable Control Mode: PR

Section 7.10

Unit: N/A

Range: 0x00000000 ~ 0xFFFFFFFF

Data Size: 32-bit

Display Format: Decimal

Settings:

Refer to P6-02 for explanation.

P6 - 11	PDAT5	Data of Path 5	Address: 0616H, 0617H
----------------	--------------	-----------------------	------------------------------

Default: 0

Related Section:

Applicable Control Mode: PR

Section 7.10

Unit: N/A

Range: -2147483648 ~ +2147483647

Data Size: 32-bit

Display Format: Decimal

Settings:

Refer to P6-03 for explanation.

ASDA-A2**Chapter 8 Servo Parameters**

P6 - 12	PDEF6	Definition of Path 6	Address: 0618H, 0619H
----------------	--------------	-----------------------------	------------------------------

Default: 0x00000000

Related Section:

Applicable Control Mode: PR

Section 7.10

Unit: N/A

Range: 0x00000000 ~ 0xFFFFFFFF

Data Size: 32-bit

Display Format: Decimal

Settings:

Refer to P6-02 for explanation.

P6 - 13	PDAT6	Data of Path 6	Address: 061AH, 061BH
----------------	--------------	-----------------------	------------------------------

Default: 0

Related Section:

Applicable Control Mode: PR

Section 7.10

Unit: N/A

Range: -2147483648 ~ +2147483647

Data Size: 32-bit

Display Format: Decimal

Settings:

Refer to P6-03 for explanation.

P6 - 14	PDEF7	Definition of Path 7	Address: 061CH, 061DH
----------------	--------------	-----------------------------	------------------------------

Default: 0x00000000

Related Section:

Applicable Control Mode: PR

Section 7.10

Unit: N/A

Range: 0x00000000 ~ 0xFFFFFFFF

Data Size: 32-bit

Display Format: Decimal

Settings:

Refer to P6-02 for explanation.

P6 - 15	PDAT7	Data of Path 7	Address: 061EH, 061FH
----------------	--------------	-----------------------	------------------------------

Default: 0

Related Section:

Applicable Control Mode: PR

Section 7.10

Unit: N/A

Range: -2147483648 ~ +2147483647

Data Size: 32-bit

Display Format: Decimal

Settings:

Refer to P6-03 for explanation.

P6 - 16	PDEF8	Definition of Path 8	Address: 0620H, 0621H
----------------	--------------	-----------------------------	------------------------------

Default: 0x00000000

Related Section:

Applicable Control Mode: PR

Section 7.10

Unit: N/A

Range: 0x00000000 ~ 0xFFFFFFFF

Data Size: 32-bit

Display Format: Decimal

Settings:

Refer to P6-02 for explanation.

P6 - 17	PDAT8	Data of Path 8	Address: 0622H, 0623H
----------------	--------------	-----------------------	------------------------------

Default: 0

Related Section:

Applicable Control Mode: PR

Section 7.10

Unit: N/A

Range: -2147483648 ~ +2147483647

Data Size: 32-bit

Display Format: Decimal

Settings:

Refer to P6-03 for explanation.

P6 - 18	PDEF9	Definition of Path 9	Address: 0624H, 0625H
----------------	--------------	-----------------------------	------------------------------

Default: 0x00000000

Related Section:

Applicable Control Mode: PR

Section 7.10

Unit: N/A

Range: 0x00000000 ~ 0xFFFFFFFF

Data Size: 32-bit

Display Format: Decimal

Settings:

Refer to P6-02 for explanation.

ASDA-A2**Chapter 8 Servo Parameters**

P6 - 19	PDAT9	Data of Path 9	Address: 0626H, 0627H
----------------	--------------	-----------------------	------------------------------

Default: 0

Related Section:

Applicable Control Mode: PR

Section 7.10

Unit: N/A

Range: -2147483648 ~ +2147483647

Data Size: 32-bit

Display Format: Decimal

Settings:

Refer to P6-03 for explanation.

P6 - 20	PDEF10	Definition of Path 10	Address: 0628H, 0629H
----------------	---------------	------------------------------	------------------------------

Default: 0x00000000

Related Section:

Applicable Control Mode: PR

Section 7.10

Unit: N/A

Range: 0x00000000 ~ 0xFFFFFFFF

Data Size: 32-bit

Display Format: Decimal

Settings:

Refer to P6-02 for explanation.

P6 - 21	PDAT10	Data of Path 10	Address: 062AH, 062BH
----------------	---------------	------------------------	------------------------------

Default: 0

Related Section:

Applicable Control Mode: PR

Section 7.10

Unit: N/A

Range: -2147483648 ~ +2147483647

Data Size: 32-bit

Display Format: Decimal

Settings:

Refer to P6-03 for explanation.

P6 - 22	PDEF11	Definition of Path 11	Address: 062CH, 062DH
----------------	---------------	------------------------------	------------------------------

Default: 0x00000000

Related Section:

Applicable Control Mode: PR

Section 7.10

Unit: N/A

Range: 0x00000000 ~ 0xFFFFFFFF

Data Size: 32-bit

Display Format: Decimal

Settings:

Refer to P6-02 for explanation.

P6 - 23	PDAT11	Data of Path 11	Address: 062EH, 062FH
----------------	---------------	------------------------	------------------------------

Default: 0

Related Section:

Applicable Control Mode: PR

Section 7.10

Unit: N/A

Range: -2147483648 ~ +2147483647

Data Size: 32-bit

Display Format: Decimal

Settings:

Refer to P6-03 for explanation.

P6 - 24	PDEF12	Definition of Path 12	Address: 0630H, 0631H
----------------	---------------	------------------------------	------------------------------

Default: 0x00000000

Related Section:

Applicable Control Mode: PR

Section 7.10

Unit: N/A

Range: 0x00000000 ~ 0xFFFFFFFF

Data Size: 32-bit

Display Format: Decimal

Settings:

Refer to P6-02 for explanation.

P6 - 25	PDAT12	Data of Path 12	Address: 0632H, 0633H
----------------	---------------	------------------------	------------------------------

Default: 0

Related Section:

Applicable Control Mode: PR

Section 7.10

Unit: N/A

Range: -2147483648 ~ +2147483647

Data Size: 32-bit

Display Format: Decimal

Settings:

Refer to P6-03 for explanation.

ASDA-A2**Chapter 8 Servo Parameters**

P6 - 26	PDEF13	Definition of Path 13	Address: 0634H, 0635H
----------------	---------------	------------------------------	------------------------------

Default: 0x00000000

Related Section:

Applicable Control Mode: PR

Section 7.10

Unit: N/A

Range: 0x00000000 ~ 0xFFFFFFFF

Data Size: 32-bit

Display Format: Decimal

Settings:

Refer to P6-02 for explanation.

P6 - 27	PDAT13	Data of Path 13	Address: 0636H, 0637H
----------------	---------------	------------------------	------------------------------

Default: 0

Related Section:

Applicable Control Mode: PR

Section 7.10

Unit: N/A

Range: -2147483648 ~ +2147483647

Data Size: 32-bit

Display Format: Decimal

Settings:

Refer to P6-03 for explanation.

P6 - 28	PDEF14	Definition of Path 14	Address: 0638H, 0639H
----------------	---------------	------------------------------	------------------------------

Default: 0x00000000

Related Section:

Applicable Control Mode: PR

Section 7.10

Unit: N/A

Range: 0x00000000 ~ 0xFFFFFFFF

Data Size: 32-bit

Display Format: Decimal

Settings:

Refer to P6-02 for explanation.

P6 - 29	PDAT14	Data of Path 14	Address: 063AH, 063BH
----------------	---------------	------------------------	------------------------------

Default: 0

Related Section:

Applicable Control Mode: PR

Section 7.10

Unit: N/A

Range: -2147483648 ~ +2147483647

Data Size: 32-bit

Display Format: Decimal

Settings:

Refer to P6-03 for explanation.

P6 - 30	PDEF15	Definition of Path 15	Address: 063CH, 063DH
----------------	---------------	------------------------------	------------------------------

Default: 0x00000000

Related Section:

Applicable Control Mode: PR

Section 7.10

Unit: N/A

Range: 0x00000000 ~ 0xFFFFFFFF

Data Size: 32-bit

Display Format: Decimal

Settings:

Refer to P6-02 for explanation.

P6 - 31	PDAT15	Data of Path 15	Address: 063EH, 063FH
----------------	---------------	------------------------	------------------------------

Default: 0

Related Section:

Applicable Control Mode: PR

Section 7.10

Unit: N/A

Range: -2147483648 ~ +2147483647

Data Size: 32-bit

Display Format: Decimal

Settings:

Refer to P6-03 for explanation.

P6 - 32	PDEF16	Definition of Path 16	Address: 0640H, 0641H
----------------	---------------	------------------------------	------------------------------

Default: 0x00000000

Related Section:

Applicable Control Mode: PR

Section 7.10

Unit: N/A

Range: 0x00000000 ~ 0xFFFFFFFF

Data Size: 32-bit

Display Format: Decimal

Settings:

Refer to P6-02 for explanation.

ASDA-A2**Chapter 8 Servo Parameters**

P6 - 33	PDAT16	Data of Path 16	Address: 0642H, 0643H
----------------	---------------	------------------------	------------------------------

Default: 0

Related Section:

Applicable Control Mode: PR

Section 7.10

Unit: N/A

Range: -2147483648 ~ +2147483647

Data Size: 32-bit

Display Format: Decimal

Settings:

Refer to P6-03 for explanation.

P6 - 34	PDEF17	Definition of Path 17	Address: 0644H, 0645H
----------------	---------------	------------------------------	------------------------------

Default: 0x00000000

Related Section:

Applicable Control Mode: PR

Section 7.10

Unit: N/A

Range: 0x00000000 ~ 0xFFFFFFFF

Data Size: 32-bit

Display Format: Decimal

Settings:

Refer to P6-02 for explanation.

P6 - 35	PDAT17	Data of Path 17	Address: 0646H, 0647H
----------------	---------------	------------------------	------------------------------

Default: 0

Related Section:

Applicable Control Mode: PR

Section 7.10

Unit: N/A

Range: -2147483648 ~ +2147483647

Data Size: 32-bit

Display Format: Decimal

Settings:

Refer to P6-03 for explanation.

P6 - 36	PDEF18	Definition of Path 18	Address: 0648H, 0649H
----------------	---------------	------------------------------	------------------------------

Default: 0x00000000

Related Section:

Applicable Control Mode: PR

Section 7.10

Unit: N/A

Range: 0x00000000 ~ 0xFFFFFFFF

Data Size: 32-bit

Display Format: Decimal

Settings:

Refer to P6-02 for explanation.

P6 - 37	PDAT18	Data of Path 18	Address: 064AH, 064BH
----------------	---------------	------------------------	------------------------------

Default: 0

Related Section:

Applicable Control Mode: PR

Section 7.10

Unit: N/A

Range: -2147483648 ~ +2147483647

Data Size: 32-bit

Display Format: Decimal

Settings:

Refer to P6-03 for explanation.

P6 - 38	PDEF19	Definition of Path 19	Address: 064CH, 064DH
----------------	---------------	------------------------------	------------------------------

Default: 0x00000000

Related Section:

Applicable Control Mode: PR

Section 7.10

Unit: N/A

Range: 0x00000000 ~ 0xFFFFFFFF

Data Size: 32-bit

Display Format: Decimal

Settings:

Refer to P6-02 for explanation.

P6 - 39	PDAT19	Data of Path 19	Address: 064EH, 064FH
----------------	---------------	------------------------	------------------------------

Default: 0

Related Section:

Applicable Control Mode: PR

Section 7.10

Unit: N/A

Range: -2147483648 ~ +2147483647

Data Size: 32-bit

Display Format: Decimal

Settings:

Refer to P6-03 for explanation.

ASDA-A2**Chapter 8 Servo Parameters**

P6 - 40	PDEF20	Definition of Path 20	Address: 0650H, 0651H
----------------	---------------	------------------------------	------------------------------

Default: 0x00000000

Related Section:

Applicable Control Mode: PR

Section 7.10

Unit: N/A

Range: 0x00000000 ~ 0xFFFFFFFF

Data Size: 32-bit

Display Format: Decimal

Settings:

Refer to P6-02 for explanation.

P6 - 41	PDAT20	Data of Path 20	Address: 0652H, 0653H
----------------	---------------	------------------------	------------------------------

Default: 0

Related Section:

Applicable Control Mode: PR

Section 7.10

Unit: N/A

Range: -2147483648 ~ +2147483647

Data Size: 32-bit

Display Format: Decimal

Settings:

Refer to P6-03 for explanation.

P6 - 42	PDEF21	Definition of Path 21	Address: 0654H, 0655H
----------------	---------------	------------------------------	------------------------------

Default: 0x00000000

Related Section:

Applicable Control Mode: PR

Section 7.10

Unit: N/A

Range: 0x00000000 ~ 0xFFFFFFFF

Data Size: 32-bit

Display Format: Decimal

Settings:

Refer to P6-02 for explanation.

P6 - 43	PDAT21	Data of Path 21	Address: 0656H, 0657H
----------------	---------------	------------------------	------------------------------

Default: 0

Related Section:

Applicable Control Mode: PR

Section 7.10

Unit: N/A

Range: -2147483648 ~ +2147483647

Data Size: 32-bit

Display Format: Decimal

Settings:

Refer to P6-03 for explanation.

P6 - 44	PDEF22	Definition of Path 22	Address: 0658H, 0659H
----------------	---------------	------------------------------	------------------------------

Default: 0x00000000

Related Section:

Applicable Control Mode: PR

Section 7.10

Unit: N/A

Range: 0x00000000 ~ 0xFFFFFFFF

Data Size: 32-bit

Display Format: Decimal

Settings:

Refer to P6-02 for explanation.

P6 - 45	PDAT22	Data of Path 22	Address: 065AH, 065BH
----------------	---------------	------------------------	------------------------------

Default: 0

Related Section:

Applicable Control Mode: PR

Section 7.10

Unit: N/A

Range: -2147483648 ~ +2147483647

Data Size: 32-bit

Display Format: Decimal

Settings:

Refer to P6-03 for explanation.

P6 - 46	PDEF23	Definition of Path 23	Address: 065CH, 065DH
----------------	---------------	------------------------------	------------------------------

Default: 0x00000000

Related Section:

Applicable Control Mode: PR

Section 7.10

Unit: N/A

Range: 0x00000000 ~ 0xFFFFFFFF

Data Size: 32-bit

Display Format: Decimal

Settings:

Refer to P6-02 for explanation.

ASDA-A2**Chapter 8 Servo Parameters**

P6 - 47	PDAT23	Data of Path 23	Address: 065EH, 065FH
----------------	---------------	------------------------	------------------------------

Default: 0

Related Section:

Applicable Control Mode: PR

Section 7.10

Unit: N/A

Range: -2147483648 ~ +2147483647

Data Size: 32-bit

Display Format: Decimal

Settings:

Refer to P6-03 for explanation.

P6 - 48	PDEF24	Definition of Path 24	Address: 0660H, 0661H
----------------	---------------	------------------------------	------------------------------

Default: 0x00000000

Related Section:

Applicable Control Mode: PR

Section 7.10

Unit: N/A

Range: 0x00000000 ~ 0xFFFFFFFF

Data Size: 32-bit

Display Format: Decimal

Settings:

Refer to P6-02 for explanation.

P6 - 49	PDAT24	Data of Path 24	Address: 0662H, 0663H
----------------	---------------	------------------------	------------------------------

Default: 0

Related Section:

Applicable Control Mode: PR

Section 7.10

Unit: N/A

Range: -2147483648 ~ +2147483647

Data Size: 32-bit

Display Format: Decimal

Settings:

Refer to P6-03 for explanation.

P6 - 50	PDEF25	Definition of Path 25	Address: 0664H, 0665H
----------------	---------------	------------------------------	------------------------------

Default: 0x00000000

Related Section:

Applicable Control Mode: PR

Section 7.10

Unit: N/A

Range: 0x00000000 ~ 0xFFFFFFFF

Data Size: 32-bit

Display Format: Decimal

Settings:

Refer to P6-02 for explanation.

P6 - 51	PDAT25	Data of Path 25	Address: 0666H, 0667H
----------------	---------------	------------------------	------------------------------

Default: 0

Related Section:

Applicable Control Mode: PR

Section 7.10

Unit: N/A

Range: -2147483648 ~ +2147483647

Data Size: 32-bit

Display Format: Decimal

Settings:

Refer to P6-03 for explanation.

P6 - 52	PDEF26	Definition of Path 26	Address: 0668H, 0669H
----------------	---------------	------------------------------	------------------------------

Default: 0x00000000

Related Section:

Applicable Control Mode: PR

Section 7.10

Unit: N/A

Range: 0x00000000 ~ 0xFFFFFFFF

Data Size: 32-bit

Display Format: Decimal

Settings:

Refer to P6-02 for explanation.

P6 - 53	PDAT26	Data of Path 26	Address: 066AH, 066BH
----------------	---------------	------------------------	------------------------------

Default: 0

Related Section:

Applicable Control Mode: PR

Section 7.10

Unit: N/A

Range: -2147483648 ~ +2147483647

Data Size: 32-bit

Display Format: Decimal

Settings:

Refer to P6-03 for explanation.

ASDA-A2**Chapter 8 Servo Parameters**

P6 - 54	PDEF27	Definition of Path 27	Address: 066CH, 066DH
----------------	---------------	------------------------------	------------------------------

Default: 0x00000000

Related Section:

Applicable Control Mode: PR

Section 7.10

Unit: N/A

Range: 0x00000000 ~ 0xFFFFFFFF

Data Size: 32-bit

Display Format: Decimal

Settings:

Refer to P6-02 for explanation.

P6 - 55	PDAT27	Data of Path 27	Address: 066EH, 066FH
----------------	---------------	------------------------	------------------------------

Default: 0

Related Section:

Applicable Control Mode: PR

Section 7.10

Unit: N/A

Range: -2147483648 ~ +2147483647

Data Size: 32-bit

Display Format: Decimal

Settings:

Refer to P6-03 for explanation.

P6 - 56	PDEF28	Definition of Path 28	Address: 0670H, 0671H
----------------	---------------	------------------------------	------------------------------

Default: 0x00000000

Related Section:

Applicable Control Mode: PR

Section 7.10

Unit: N/A

Range: 0x00000000 ~ 0xFFFFFFFF

Data Size: 32-bit

Display Format: Decimal

Settings:

Refer to P6-02 for explanation.

P6 - 57	PDAT28	Data of Path 28	Address: 0672H, 0673H
----------------	---------------	------------------------	------------------------------

Default: 0

Related Section:

Applicable Control Mode: PR

Section 7.10

Unit: N/A

Range: -2147483648 ~ +2147483647

Data Size: 32-bit

Display Format: Decimal

Settings:

Refer to P6-03 for explanation.

P6 - 58**PDEF29 Definition of Path 29****Address: 0674H, 0675H**

Default: 0x00000000

Related Section:

Applicable Control Mode: PR

Section 7.10

Unit: N/A

Range: 0x00000000 ~ 0xFFFFFFFF

Data Size: 32-bit

Display Format: Decimal

Settings:

Refer to P6-02 for explanation.

P6 - 59**PDAT29 Data of Path 29****Address: 0676H, 0677H**

Default: 0

Related Section:

Applicable Control Mode: PR

Section 7.10

Unit: N/A

Range: -2147483648 ~ +2147483647

Data Size: 32-bit

Display Format: Decimal

Settings:

Refer to P6-03 for explanation.

P6 - 60**PDEF30 Definition of Path 30****Address: 0678H, 0679H**

Default: 0x00000000

Related Section:

Applicable Control Mode: PR

Section 7.10

Unit: N/A

Range: 0x00000000 ~ 0xFFFFFFFF

Data Size: 32-bit

Display Format: Decimal

Settings:

Refer to P6-02 for explanation.

ASDA-A2**Chapter 8 Servo Parameters**

P6 - 61	PDAT30	Data of Path 30	Address: 067AH, 067BH
	Default: 0 Applicable Control Mode: PR Unit: N/A Range: -2147483648 ~ +2147483647 Data Size: 32-bit Display Format: Decimal Settings: Refer to P6-03 for explanation.		Related Section: Section 7.10
P6 - 62	PDEF31	Definition of Path 31	Address: 067CH, 067DH
	Default: 0x00000000 Applicable Control Mode: PR Unit: N/A Range: 0x00000000 ~ 0xFFFFFFFF Data Size: 32-bit Display Format: Decimal Settings: Refer to P6-02 for explanation.		Related Section: Section 7.10
P6 - 63	PDAT31	Data of Path 31	Address: 067EH, 067FH
	Default: 0 Applicable Control Mode: PR Unit: N/A Range: -2147483648 ~ +2147483647 Data Size: 32-bit Display Format: Decimal Settings: Refer to P6-03 for explanation.		Related Section: Section 7.10
P6 - 64	PDEF32	Definition of Path 32	Address: 0680H, 0681H
	Default: 0x00000000 Applicable Control Mode: PR Unit: N/A Range: 0x00000000 ~ 0xFFFFFFFF Data Size: 32-bit		Related Section: Section 7.10

Display Format: Decimal

Settings:

Refer to P6-02 for explanation.

P6 - 65	PDAT32	Data of Path 32	Address: 0682H, 0683H
----------------	---------------	------------------------	------------------------------

Default: 0

Related Section:

Applicable Control Mode: PR

Section 7.10

Unit: N/A

Range: -2147483648 ~ +2147483647

Data Size: 32-bit

Display Format: Decimal

Settings:

Refer to P6-03 for explanation.

P6 - 66	PDEF33	Definition of Path 33	Address: 0684H, 0685H
----------------	---------------	------------------------------	------------------------------

Default: 0x00000000

Related Section:

Applicable Control Mode: PR

Section 7.10

Unit: N/A

Range: 0x00000000 ~ 0xFFFFFFFF

Data Size: 32-bit

Display Format: Decimal

Settings:

Refer to P6-02 for explanation.

P6 - 67	PDAT33	Data of Path 33	Address: 0686H, 0687H
----------------	---------------	------------------------	------------------------------

Default: 0

Related Section:

Applicable Control Mode: PR

Section 7.10

Unit: N/A

Range: -2147483648 ~ +2147483647

Data Size: 32-bit

Display Format: Decimal

Settings:

Refer to P6-03 for explanation.

ASDA-A2**Chapter 8 Servo Parameters**

P6 - 68	PDEF34	Definition of Path 34	Address: 0688H, 0689H
----------------	---------------	------------------------------	------------------------------

Default: 0x00000000

Related Section:

Applicable Control Mode: PR

Section 7.10

Unit: N/A

Range: 0x00000000 ~ 0xFFFFFFFF

Data Size: 32-bit

Display Format: Decimal

Settings:

Refer to P6-02 for explanation.

P6 - 69	PDAT34	Data of Path 34	Address: 068AH, 068BH
----------------	---------------	------------------------	------------------------------

Default: 0

Related Section:

Applicable Control Mode: PR

Section 7.10

Unit: N/A

Range: -2147483648 ~ +2147483647

Data Size: 32-bit

Display Format: Decimal

Settings:

Refer to P6-03 for explanation.

P6 - 70	PDEF35	Definition of Path 35	Address: 068CH, 068DH
----------------	---------------	------------------------------	------------------------------

Default: 0x00000000

Related Section:

Applicable Control Mode: PR

Section 7.10

Unit: N/A

Range: 0x00000000 ~ 0xFFFFFFFF

Data Size: 32-bit

Display Format: Decimal

Settings:

Refer to P6-02 for explanation.

P6 - 71	PDAT35	Data of Path 35	Address: 068EH, 068FH
----------------	---------------	------------------------	------------------------------

Default: 0

Related Section:

Applicable Control Mode: PR

Section 7.10

Unit: N/A

Range: -2147483648 ~ +2147483647

Data Size: 32-bit

Chapter 8 Servo Parameters**ASDA-A2**

Display Format: Decimal

Settings:

Refer to P6-03 for explanation.

P6 - 72	PDEF36	Definition of Path 36	Address: 0690H, 0691H
----------------	---------------	------------------------------	------------------------------

Default: 0x00000000

Related Section:

Applicable Control Mode: PR

Section 7.10

Unit: N/A

Range: 0x00000000 ~ 0xFFFFFFFF

Data Size: 32-bit

Display Format: Decimal

Settings:

Refer to P6-02 for explanation.

P6 - 73	PDAT36	Data of Path 36	Address: 0692H, 0693H
----------------	---------------	------------------------	------------------------------

Default: 0

Related Section:

Applicable Control Mode: PR

Section 7.10

Unit: N/A

Range: -2147483648 ~ +2147483647

Data Size: 32-bit

Display Format: Decimal

Settings:

Refer to P6-03 for explanation.

P6 - 74	PDEF37	Definition of Path 37	Address: 0694H, 0695H
----------------	---------------	------------------------------	------------------------------

Default: 0x00000000

Related Section:

Applicable Control Mode: PR

Section 7.10

Unit: N/A

Range: 0x00000000 ~ 0xFFFFFFFF

Data Size: 32-bit

Display Format: Decimal

Settings:

Refer to P6-02 for explanation.

ASDA-A2**Chapter 8 Servo Parameters**

P6 - 75	PDAT37	Data of Path 37	Address: 0696H, 0697H
----------------	---------------	------------------------	------------------------------

Default: 0

Related Section:

Applicable Control Mode: PR

Section 7.10

Unit: N/A

Range: -2147483648 ~ +2147483647

Data Size: 32-bit

Display Format: Decimal

Settings:

Refer to P6-03 for explanation.

P6 - 76	PDEF38	Definition of Path 38	Address: 0698H, 0699H
----------------	---------------	------------------------------	------------------------------

Default: 0x00000000

Related Section:

Applicable Control Mode: PR

Section 7.10

Unit: N/A

Range: 0x00000000 ~ 0xFFFFFFFF

Data Size: 32-bit

Display Format: Decimal

Settings:

Refer to P6-02 for explanation.

P6 - 77	PDAT38	Data of Path 38	Address: 069AH, 069BH
----------------	---------------	------------------------	------------------------------

Default: 0

Related Section:

Applicable Control Mode: PR

Section 7.10

Unit: N/A

Range: -2147483648 ~ +2147483647

Data Size: 32-bit

Display Format: Decimal

Settings:

Refer to P6-03 for explanation.

P6 - 78	PDEF39	Definition of Path 39	Address: 069CH, 069DH
----------------	---------------	------------------------------	------------------------------

Default: 0x00000000

Related Section:

Applicable Control Mode: PR

Section 7.10

Unit: N/A

Range: 0x00000000 ~ 0xFFFFFFFF

Data Size: 32-bit

Chapter 8 Servo Parameters**ASDA-A2**

Display Format: Decimal

Settings:

Refer to P6-02 for explanation.

P6 - 79	PDAT39	Data of Path 39	Address: 069EH, 069FH
----------------	---------------	------------------------	------------------------------

Default: 0

Related Section:

Applicable Control Mode: PR

Section 7.10

Unit: N/A

Range: -2147483648 ~ +2147483647

Data Size: 32-bit

Display Format: Decimal

Settings:

Refer to P6-03 for explanation.

P6 - 80	PDEF40	Definition of Path 40	Address: 06A0H, 06A1H
----------------	---------------	------------------------------	------------------------------

Default: 0x00000000

Related Section:

Applicable Control Mode: PR

Section 7.10

Unit: N/A

Range: 0x00000000 ~ 0xFFFFFFFF

Data Size: 32-bit

Display Format: Decimal

Settings:

Refer to P6-02 for explanation.

P6 - 81	PDAT40	Data of Path 40	Address: 06A2H, 06A3H
----------------	---------------	------------------------	------------------------------

Default: 0

Related Section:

Applicable Control Mode: PR

Section 7.10

Unit: N/A

Range: -2147483648 ~ +2147483647

Data Size: 32-bit

Display Format: Decimal

Settings:

Refer to P6-03 for explanation.

ASDA-A2**Chapter 8 Servo Parameters**

P6 - 82	PDEF41	Definition of Path 41	Address: 06A4H, 06A5H
----------------	---------------	------------------------------	------------------------------

Default: 0x00000000

Related Section:

Applicable Control Mode: PR

Section 7.10

Unit: N/A

Range: 0x00000000 ~ 0xFFFFFFFF

Data Size: 32-bit

Display Format: Decimal

Settings:

Refer to P6-02 for explanation.

P6 - 83	PDAT41	Data of Path 41	Address: 06A6H, 06A7H
----------------	---------------	------------------------	------------------------------

Default: 0

Related Section:

Applicable Control Mode: PR

Section 7.10

Unit: N/A

Range: -2147483648 ~ +2147483647

Data Size: 32-bit

Display Format: Decimal

Settings:

Refer to P6-03 for explanation.

P6 - 84	PDEF42	Definition of Path 42	Address: 06A8H, 06A9H
----------------	---------------	------------------------------	------------------------------

Default: 0x00000000

Related Section:

Applicable Control Mode: PR

Section 7.10

Unit: N/A

Range: 0x00000000 ~ 0xFFFFFFFF

Data Size: 32-bit

Display Format: Decimal

Settings:

Refer to P6-02 for explanation.

P6 - 85	PDAT42	Data of Path 42	Address: 06AAH, 06ABH
----------------	---------------	------------------------	------------------------------

Default: 0

Related Section:

Applicable Control Mode: PR

Section 7.10

Unit: N/A

Range: -2147483648 ~ +2147483647

Data Size: 32-bit

Display Format: Decimal

Settings:

Refer to P6-03 for explanation.

P6 - 86**PDEF43 Definition of Path 43****Address: 06ACH, 06ADH**

Default: 0x00000000

Related Section:

Applicable Control Mode: PR

Section 7.10

Unit: N/A

Range: 0x00000000 ~ 0xFFFFFFFF

Data Size: 32-bit

Display Format: Decimal

Settings:

Refer to P6-02 for explanation.

P6 - 87**PDAT43 Data of Path 43****Address: 06AEH, 06AFH**

Default: 0

Related Section:

Applicable Control Mode: PR

Section 7.10

Unit: N/A

Range: -2147483648 ~ +2147483647

Data Size: 32-bit

Display Format: Decimal

Settings:

Refer to P6-03 for explanation.

P6 - 88**PDEF44 Definition of Path 44****Address: 06B0H, 06B1H**

Default: 0x00000000

Related Section:

Applicable Control Mode: PR

Section 7.10

Unit: N/A

Range: 0x00000000 ~ 0xFFFFFFFF

Data Size: 32-bit

Display Format: Decimal

Settings:

Refer to P6-02 for explanation.

ASDA-A2**Chapter 8 Servo Parameters**

P6 - 89	PDAT44	Data of Path 44	Address: 06B2H, 06B3H
----------------	---------------	------------------------	------------------------------

Default: 0

Related Section:

Applicable Control Mode: PR

Section 7.10

Unit: N/A

Range: -2147483648 ~ +2147483647

Data Size: 32-bit

Display Format: Decimal

Settings:

Refer to P6-03 for explanation.

P6 - 90	PDEF45	Definition of Path 45	Address: 06B4H, 06B5H
----------------	---------------	------------------------------	------------------------------

Default: 0x00000000

Related Section:

Applicable Control Mode: PR

Section 7.10

Unit: N/A

Range: 0x00000000 ~ 0xFFFFFFFF

Data Size: 32-bit

Display Format: Decimal

Settings:

Refer to P6-02 for explanation.

P6 - 91	PDAT45	Data of Path 45	Address: 06B6H, 06B7H
----------------	---------------	------------------------	------------------------------

Default: 0

Related Section:

Applicable Control Mode: PR

Section 7.10

Unit: N/A

Range: -2147483648 ~ +2147483647

Data Size: 32-bit

Display Format: Decimal

Settings:

Refer to P6-03 for explanation.

P6 - 92	PDEF46	Definition of Path 46	Address: 06B8H, 06B9H
----------------	---------------	------------------------------	------------------------------

Default: 0x00000000

Related Section:

Applicable Control Mode: PR

Section 7.10

Unit: N/A

Range: 0x00000000 ~ 0xFFFFFFFF

Data Size: 32-bit

Chapter 8 Servo Parameters**ASDA-A2**

Display Format: Decimal

Settings:

Refer to P6-02 for explanation.

P6 - 93	PDAT46	Data of Path 46	Address: 06BAH, 06BBH
----------------	---------------	------------------------	------------------------------

Default: 0

Related Section:

Applicable Control Mode: PR

Section 7.10

Unit: N/A

Range: -2147483648 ~ +2147483647

Data Size: 32-bit

Display Format: Decimal

Settings:

Refer to P6-03 for explanation.

P6 - 94	PDEF47	Definition of Path 47	Address: 06BCH, 06BDH
----------------	---------------	------------------------------	------------------------------

Default: 0x00000000

Related Section:

Applicable Control Mode: PR

Section 7.10

Unit: N/A

Range: 0x00000000 ~ 0xFFFFFFFF

Data Size: 32-bit

Display Format: Decimal

Settings:

Refer to P6-02 for explanation.

P6 - 95	PDAT47	Data of Path 47	Address: 06BEH, 06BFH
----------------	---------------	------------------------	------------------------------

Default: 0

Related Section:

Applicable Control Mode: PR

Section 7.10

Unit: N/A

Range: -2147483648 ~ +2147483647

Data Size: 32-bit

Display Format: Decimal

Settings:

Refer to P6-03 for explanation.

ASDA-A2**Chapter 8 Servo Parameters**

P6 - 96	PDEF48	Definition of Path 48	Address: 06C0H, 06C1H
----------------	---------------	------------------------------	------------------------------

Default: 0x00000000

Related Section:

Applicable Control Mode: PR

Section 7.10

Unit: N/A

Range: 0x00000000 ~ 0xFFFFFFFF

Data Size: 32-bit

Display Format: Decimal

Settings:

Refer to P6-02 for explanation.

P6 - 97	PDAT48	Data of Path 48	Address: 06C2H, 06C3H
----------------	---------------	------------------------	------------------------------

Default: 0

Related Section:

Applicable Control Mode: PR

Section 7.10

Unit: N/A

Range: -2147483648 ~ +2147483647

Data Size: 32-bit

Display Format: Decimal

Settings:

Refer to P6-03 for explanation.

P6 - 98	PDEF49	Definition of Path 49	Address: 06C4H, 06C5H
----------------	---------------	------------------------------	------------------------------

Default: 0x00000000

Related Section:

Applicable Control Mode: PR

Section 7.10

Unit: N/A

Range: 0x00000000 ~ 0xFFFFFFFF

Data Size: 32-bit

Display Format: Decimal

Settings:

Refer to P6-02 for explanation.

P6 - 99	PDAT49	Data of Path 49	Address: 06C6H, 06C7H
----------------	---------------	------------------------	------------------------------

Default: 0

Related Section:

Applicable Control Mode: PR

Section 7.10

Unit: N/A

Range: -2147483648 ~ +2147483647

Data Size: 32-bit

Display Format: Decimal

Settings:

Refer to P6-03 for explanation.

Group 7: P7-xx PR Path Definition Parameters

P7 - 00	PDEF50	Definition of Path 50	Address: 0700H, 0701H
----------------	---------------	------------------------------	------------------------------

Default: 0x00000000

Related Section:

Applicable Control Mode: PR

Section 7.10

Unit: N/A

Range: 0x00000000 ~ 0xFFFFFFFF

Data Size: 32-bit

Display Format: Decimal

Settings:

Refer to P6-02 for explanation.

P7 - 01	PDAT50	Data of Path 50	Address: 0702H, 0703H
----------------	---------------	------------------------	------------------------------

Default: 0

Related Section:

Applicable Control Mode: PR

Section 7.10

Unit: N/A

Range: -2147483648 ~ +2147483647

Data Size: 32-bit

Display Format: Decimal

Settings:

Refer to P6-03 for explanation.

P7 - 02	PDEF51	Definition of Path 51	Address: 0704H, 0705H
----------------	---------------	------------------------------	------------------------------

Default: 0x00000000

Related Section:

Applicable Control Mode: PR

Section 7.10

Unit: N/A

Range: 0x00000000 ~ 0xFFFFFFFF

Data Size: 32-bit

Display Format: Decimal

Settings:

Refer to P6-02 for explanation.

Chapter 8 Servo Parameters**ASDA-A2**

P7 - 03	PDAT51	Data of Path 51	Address: 0706H, 0707H
Default: 0		Related Section:	
Applicable Control Mode: PR		Section 7.10	
Unit: N/A			
Range: -2147483648 ~ +2147483647			
Data Size: 32-bit			
Display Format: Decimal			
Settings:			
Refer to P6-03 for explanation.			

P7 - 04	PDEF52	Definition of Path 52	Address: 0708H, 0709H
Default: 0x00000000		Related Section:	
Applicable Control Mode: PR		Section 7.10	
Unit: N/A			
Range: 0x00000000 ~ 0xFFFFFFFF			
Data Size: 32-bit			
Display Format: Decimal			
Settings:			
Refer to P6-02 for explanation.			

P7 - 05	PDAT52	Data of Path 52	Address: 070AH, 070BH
Default: 0		Related Section:	
Applicable Control Mode: PR		Section 7.10	
Unit: N/A			
Range: -2147483648 ~ +2147483647			
Data Size: 32-bit			
Display Format: Decimal			
Settings:			
Refer to P6-03 for explanation.			

ASDA-A2**Chapter 8 Servo Parameters**

P7 - 06	PDEF53	Definition of Path 53	Address: 070CH, 070DH
Default: 0x00000000		Related Section:	
Applicable Control Mode: PR		Section 7.10	
Unit: N/A			
Range: 0x00000000 ~ 0xFFFFFFFF			
Data Size: 32-bit			
Display Format: Decimal			
Settings:			
Refer to P6-02 for explanation.			

P7 - 07	PDAT53	Data of Path 53	Address: 070EH, 070FH
Default: 0		Related Section:	
Applicable Control Mode: PR		Section 7.10	
Unit: N/A			
Range: -2147483648 ~ +2147483647			
Data Size: 32-bit			
Display Format: Decimal			
Settings:			
Refer to P6-03 for explanation.			

P7 - 08	PDEF54	Definition of Path 54	Address: 0710H, 0711H
Default: 0x00000000		Related Section:	
Applicable Control Mode: PR		Section 7.10	
Unit: N/A			
Range: 0x00000000 ~ 0xFFFFFFFF			
Data Size: 32-bit			
Display Format: Decimal			
Settings:			
Refer to P6-02 for explanation.			

Chapter 8 Servo Parameters**ASDA-A2**

P7 - 09	PDAT54	Data of Path 54	Address: 0712H, 0713H
Default: 0		Related Section:	
Applicable Control Mode: PR		Section 7.10	
Unit: N/A			
Range: -2147483648 ~ +2147483647			
Data Size: 32-bit			
Display Format: Decimal			
Settings:			
Refer to P6-03 for explanation.			

P7 - 10	PDEF55	Definition of Path 55	Address: 0714H, 0715H
Default: 0x00000000		Related Section:	
Applicable Control Mode: PR		Section 7.10	
Unit: N/A			
Range: 0x00000000 ~ 0xFFFFFFFF			
Data Size: 32-bit			
Display Format: Decimal			
Settings:			
Refer to P6-02 for explanation.			

P7 - 11	PDAT55	Data of Path 55	Address: 0716H, 0717H
Default: 0		Related Section:	
Applicable Control Mode: PR		Section 7.10	
Unit: N/A			
Range: -2147483648 ~ +2147483647			
Data Size: 32-bit			
Display Format: Decimal			
Settings:			
Refer to P6-03 for explanation.			

ASDA-A2**Chapter 8 Servo Parameters**

P7 - 12	PDEF56	Definition of Path 56	Address: 0718H, 0719H
Default: 0x00000000		Related Section:	
Applicable Control Mode: PR		Section 7.10	
Unit: N/A			
Range: 0x00000000 ~ 0xFFFFFFFF			
Data Size: 32-bit			
Display Format: Decimal			
Settings:			
Refer to P6-02 for explanation.			

P7 - 13	PDAT56	Data of Path 56	Address: 071AH, 071BH
Default: 0		Related Section:	
Applicable Control Mode: PR		Section 7.10	
Unit: N/A			
Range: -2147483648 ~ +2147483647			
Data Size: 32-bit			
Display Format: Decimal			
Settings:			
Refer to P6-03 for explanation.			

P7 - 14	PDEF57	Definition of Path 57	Address: 071CH, 071DH
Default: 0x00000000		Related Section:	
Applicable Control Mode: PR		Section 7.10	
Unit: N/A			
Range: 0x00000000 ~ 0xFFFFFFFF			
Data Size: 32-bit			
Display Format: Decimal			
Settings:			
Refer to P6-02 for explanation.			

Chapter 8 Servo Parameters**ASDA-A2**

P7 - 15	PDAT57	Data of Path 57	Address: 071EH, 071FH
----------------	---------------	------------------------	------------------------------

Default: 0

Related Section:

Applicable Control Mode: PR

Section 7.10

Unit: N/A

Range: -2147483648 ~ +2147483647

Data Size: 32-bit

Display Format: Decimal

Settings:

Refer to P6-03 for explanation.

P7 - 16	PDEF58	Definition of Path 58	Address: 0720H, 0721H
----------------	---------------	------------------------------	------------------------------

Default: 0x00000000

Related Section:

Applicable Control Mode: PR

Section 7.10

Unit: N/A

Range: 0x00000000 ~ 0xFFFFFFFF

Data Size: 32-bit

Display Format: Decimal

Settings:

Refer to P6-02 for explanation.

P7 - 17	PDAT58	Data of Path 58	Address: 0722H, 0723H
----------------	---------------	------------------------	------------------------------

Default: 0

Related Section:

Applicable Control Mode: PR

Section 7.10

Unit: N/A

Range: -2147483648 ~ +2147483647

Data Size: 32-bit

Display Format: Decimal

Settings:

Refer to P6-03 for explanation.

ASDA-A2**Chapter 8 Servo Parameters**

P7 - 18	PDEF59	Definition of Path 59	Address: 0724H, 0725H
Default: 0x00000000		Related Section:	
Applicable Control Mode: PR		Section 7.10	
Unit: N/A			
Range: 0x00000000 ~ 0xFFFFFFFF			
Data Size: 32-bit			
Display Format: Decimal			
Settings:			
Refer to P6-02 for explanation.			
P7 - 19	PDAT59	Data of Path 59	Address: 0726H, 0727H
Default: 0		Related Section:	
Applicable Control Mode: PR		Section 7.10	
Unit: N/A			
Range: -2147483648 ~ +2147483647			
Data Size: 32-bit			
Display Format: Decimal			
Settings:			
Refer to P6-03 for explanation.			
P7 - 20	PDEF60	Definition of Path 60	Address: 0728H, 0729H
Default: 0x00000000		Related Section:	
Applicable Control Mode: PR		Section 7.10	
Unit: N/A			
Range: 0x00000000 ~ 0xFFFFFFFF			
Data Size: 32-bit			
Display Format: Decimal			
Settings:			
Refer to P6-02 for explanation.			

Chapter 8 Servo Parameters**ASDA-A2**

P7 - 21	PDAT60	Data of Path 60	Address: 072AH, 072BH
Default: 0		Related Section:	
Applicable Control Mode: PR		Section 7.10	
Unit: N/A			
Range: -2147483648 ~ +2147483647			
Data Size: 32-bit			
Display Format: Decimal			
Settings:			
Refer to P6-03 for explanation.			

P7 - 22	PDEF61	Definition of Path 61	Address: 072CH, 072DH
Default: 0x00000000		Related Section:	
Applicable Control Mode: PR		Section 7.10	
Unit: N/A			
Range: 0x00000000 ~ 0xFFFFFFFF			
Data Size: 32-bit			
Display Format: Decimal			
Settings:			
Refer to P6-02 for explanation.			

P7 - 23	PDAT61	Data of Path 61	Address: 072EH, 072FH
Default: 0		Related Section:	
Applicable Control Mode: PR		Section 7.10	
Unit: N/A			
Range: -2147483648 ~ +2147483647			
Data Size: 32-bit			
Display Format: Decimal			
Settings:			
Refer to P6-03 for explanation.			

ASDA-A2**Chapter 8 Servo Parameters**

P7 - 24	PDEF62	Definition of Path 62	Address: 0730H, 0731H
----------------	---------------	------------------------------	------------------------------

Default: 0x00000000

Related Section:

Applicable Control Mode: PR

Section 7.10

Unit: N/A

Range: 0x00000000 ~ 0xFFFFFFFF

Data Size: 32-bit

Display Format: Decimal

Settings:

Refer to P6-02 for explanation.

P7 - 25	PDAT62	Data of Path 62	Address: 0732H, 0733H
----------------	---------------	------------------------	------------------------------

Default: 0

Related Section:

Applicable Control Mode: PR

Section 7.10

Unit: N/A

Range: -2147483648 ~ +2147483647

Data Size: 32-bit

Display Format: Decimal

Settings:

Refer to P6-03 for explanation.

P7 - 26	PDEF63	Definition of Path 63	Address: 0734H, 0735H
----------------	---------------	------------------------------	------------------------------

Default: 0x00000000

Related Section:

Applicable Control Mode: PR

Section 7.10

Unit: N/A

Range: 0x00000000 ~ 0xFFFFFFFF

Data Size: 32-bit

Display Format: Decimal

Settings:

Refer to P6-02 for explanation.

Chapter 8 Servo Parameters**ASDA-A2**

P7 - 27	PDAT63	Data of Path 63	Address: 0736H, 0737H
----------------	---------------	------------------------	------------------------------

Default: 0

Related Section:

Applicable Control Mode: PR

Section 7.10

Unit: N/A

Range: -2147483648 ~ +2147483647

Data Size: 32-bit

Display Format: Decimal

Settings:

Refer to P6-03 for explanation.

Table 8.A Input Function Definition

Setting value: 0x01			
DI Name	DI Function Description	Trigger Method	Control Mode
SON	Servo On. When this DI is activated, it indicates the servo drive is enabled.	Level Triggered	All

Setting value: 0x02			
DI Name	DI Function Description	Trigger Method	Control Mode
ARST	A number of Faults (Alarms) can be cleared by activating ARST. Please see table 10-3 for applicable faults that can be cleared with the ARST command. However, please investigate Fault or Alarm if it does not clear or the fault description warrants closer inspection of the drive system.	Rising-edge Triggered	All

Setting value: 0x03			
DI Name	DI Function Description	Trigger Method	Control Mode
GAINUP	Gain switching in speed and position mode. When GAINUP is activated (P2-27 is set to 1), the gain is switched to the gain multiplied by gain switching rate.	Level Triggered	PT, PR, S

Setting value: 0x04			
DI Name	DI Function Description	Trigger Method	Control Mode
CCLR	When CCLR is activated, the setting parameter P2-50 Pulse Clear Mode is executed. 0: After CCLR is activated (ON), the position accumulated pulse number will be cleared continuously.	Rising-edge Triggered, Level Triggered	PT, PR

Setting value: 0x05

DI Name	DI Function Description	Trigger Method	Control Mode
ZCLAMP	<p>When this signal is On and the motor speed value is lower than the setting value of P1-38, it is used to lock the motor in the instant position while ZCLAMP is On.</p>	Level Triggered	S

Setting value: 0x06

DI Name	DI Function Description	Trigger Method	Control Mode
CMDINV	Command input reverse control. When the drive is in the Position, Speed and Torque mode, and CMDINV is activated, the motor is in reverse rotation.	Level Triggered	S, T

Setting value: 0x07

DI Name	DI Function Description	Trigger Method	Control Mode
Reserved			

Setting value: 0x08

DI Name	DI Function Description	Trigger Method	Control Mode
CTRG	Command triggered (available in PR mode only). When the drive is in PR mode and CTRG is activated, the drive will command the motor to move the stored position which correspond the POS 0 ~ POS 5 settings. Activation is triggered on the rising edge of the pulse.	Rising-edge Triggered	PR

Setting value: 0x09

DI Name	DI Function Description	Trigger Method	Control Mode
TRQLM	Torque limit enabled. When the drive is in speed and position mode, and TRQLM is activated, it indicates the torque limit command is valid. The torque limit command source is internal parameter or analog voltage.	Level Triggered	PT, PR, S

Setting value: 0x10

DI Name	DI Function Description	Trigger Method	Control Mode
SPDLM	Speed limit enabled. When the drive is in torque mode and SPDLM is activated, it indicates the speed limit command is valid. The speed limit command source is internal parameter or analog voltage.	Level Triggered	T

Setting value: 0x11, 0x12, 0x13, 0x1A, 0x1B, 0x1C

DI Name	DI Function Description	Trigger Method	Control Mode
POS0 POS1 POS2 POS3 POS4 POS5	Position command selection POS0 ~ POS5 (64 positions) When the PR Control Mode is selected, the 64 stored positions are programmed via a combination of the POS 0 ~ POS 5 commands.	Level Triggered	PR

DI Name	DI Function Description									Trigger Method	Control Mode
POS0 POS1 POS2 POS3 POS4 POS5	Position Command	POS5	POS4	POS3	POS2	POS1	POS0	CTRG	Parameters	Level Triggered	PR
	P1	ON	ON	ON	ON	ON	ON	↑	P6-00 P6-01		
	P2	ON	ON	ON	ON	ON	OFF	↑	P6-02 P6-03		
	~								~		
	P50	OFF	OFF	ON	ON	OFF	ON	↑	P6-98 P6-99		
	P51	OFF	OFF	ON	ON	OFF	OFF	↑	P7-00 P7-01		
	~								~		
	P64	OFF	OFF	OFF	OFF	OFF	OFF	↑	P7-26		
								↑			

Chapter 8 Servo Parameters

ASDA-A2

Setting value: 0x46

DI Name	DI Function Description	Trigger Method	Control Mode
STOP	Motor stop.	Rising-edge Triggered	PR

Setting value: 0x14 ~ 0x15

DI Name	DI Function Description						Trigger Method	Control Mode	
SPD0 SPD1	Speed command selection 0 ~ 1 (Command S1 ~ S4)							Level Triggered	S
	Command No.	DI signal of CN1		Command Source		Content	Range		
		SPD1	SPD0	Mode	S				
	S1	OFF	OFF			Sz	External analog command		
				None	Speed command is 0		0		
S2	OFF	ON	Internal parameter		P1-09	-60000			
S3	ON	OFF			P1-10	~			

Setting value: 0x16 ~ 0x17

DI Name	DI Function Description						Trigger Method	Control Mode	
TCM0 TCM1	Torque command selection 0 ~ 1 (Command T1 ~ T4)							Level Triggered	T
	Command No.	DI signal of CN1		Command Source		Content	Range		
		TCM1	TCM0	Mode	T				
	T1	OFF	OFF			Tz	Analog command		
				None	Torque command is 0		0		
	T2	OFF	ON	Internal parameter		P1-12	-300		
T3	ON	OFF			P1-13	~			
T4	ON	ON			P1-14	+300 %			

ASDA-A2**Chapter 8 Servo Parameters****Setting value: 0x18**

DI Name	DI Function Description	Trigger Method	Control Mode
S-P	Speed / Position mode switching. OFF: Speed mode, ON: Position mode	Level Triggered	P, S

Setting value: 0x19

DI Name	DI Function Description	Trigger Method	Control Mode
S-T	Speed / Torque mode switching. OFF: Speed mode, ON: Torque mode	Level Triggered	S, T

Setting value: 0x20

DI Name	DI Function Description	Trigger Method	Control Mode
T-P	Torque / Position mode switching. OFF: Torque mode, ON: Position mode	Level Triggered	P, T

Setting value: 0x2B

DI Name	DI Function Description	Trigger Method	Control Mode
PT-PR	Internal position (PR) and external pulse (PT) mode switching. OFF: PT, ON: PR	Level Triggered	PT, PR

Setting value: 0x21

DI Name	DI Function Description	Trigger Method	Control Mode
EMGS	Emergency stop. It should be contact "b" and normally ON or a fault (AL013) will display.	Level Triggered	All

Setting value: 0x22

DI Name	DI Function Description	Trigger Method	Control Mode
NL(CWL)	Reverse inhibit limit. It should be contact "b" and normally ON or a fault (AL014) will display.	Level Triggered	All

Setting value: 0x23

DI Name	DI Function Description	Trigger Method	Control Mode
PL(CCWL)	Forward inhibit limit. It should be contact "b" and normally ON or a fault (AL015) will display.	Level Triggered	All

Chapter 8 Servo Parameters

ASDA-A2

Setting value: 0x24

DI Name	DI Function Description	Trigger Method	Control Mode
ORGP	Reference "Home" sensor. When ORGP is activated, the drive will command the motor to start to search the reference "Home" sensor. [see P5-04]	Rising-edge/ Falling-edge Triggered	PR

Setting value: 0x27

DI Name	DI Function Description	Trigger Method	Control Mode
SHOM	Move to "Home". When SHOM is activated, the drive will command the motor to move to "Home". [see P5-04]	Rising-edge Triggered	PR

Setting value: 0x36

DI Name	DI Function Description	Trigger Method	Control Mode
CAM	Electronic CAM function control [see P5-88] Please note: ASDA-A2 series L type models does not provide Electronic Cam (E-Cam) function.	Rising-edge/ Falling-edge Triggered	PR

Setting value: 0x37

DI Name	DI Function Description	Trigger Method	Control Mode
JOGU	Forward JOG input. When JOGU is activated, the motor will JOG in forward direction. [see P4-05]	Level Triggered	All

Setting value: 0x38

DI Name	DI Function Description	Trigger Method	Control Mode
JOGD	Reverse JOG input. When JOGD is activated, the motor will JOG in reverse direction. [see P4-05]	Level Triggered	All

Setting value: 0x39

DI Name	DI Function Description	Trigger Method	Control Mode
EV1	Event trigger command 1 [see P5-98, P5-99]	Rising-edge/ Falling-edge Triggered	PR

Setting value: 0x3A

DI Name	DI Function Description	Trigger Method	Control Mode
EV2	Event trigger command 2 [see P5-98, P5-99]	Rising-edge/ Falling-edge Triggered	PR

Setting value: 0x3B

DI Name	DI Function Description	Trigger Method	Control Mode
EV3	Event trigger command 3 [see P5-98, P5-99] (available in firmware version V1.009 and later models)	Rising-edge/ Falling-edge Triggered	PR

Setting value: 0x3C

DI Name	DI Function Description	Trigger Method	Control Mode
EV4	Event trigger command 4 [see P5-98, P5-99] (available in firmware version V1.009 and later models)	Rising-edge/ Falling-edge Triggered	PR

Setting value: 0x43, 0x44

DI Name	DI Function Description	Trigger Method	Control Mode
GNUM0 GNUM1	<p>Electronic gear ratio (Numerator) selection 0 ~ 1 [see P2-60 ~ P2-62]</p>	Level Triggered	PT

Setting value: 0x45

DI Name	DI Function Description	Trigger Method	Control Mode
INHP	Pulse inhibit input. When the drive is in position mode, if INHP is activated, the external pulse input command is not valid. (Please use DI8 for INHP signal to ensure the real-time operation of INHP function.)	Level Triggered	PT

 **NOTE**

-
- 1) 11 ~ 17: Single control mode, 18 ~ 20: Dual control mode
 - 2) When P2-10 to P2-17 is set to 0, it indicates input function is disabled.

Table 8.B Output Function Definition

Setting value: 0x01			
DO Name	DO Function Description	Trigger Method	Control Mode
SRDY	Servo ready. SRDY is activated when the servo drive is ready to run. All fault and alarm conditions, if present, have been cleared.	Level Triggered	All

Setting value: 0x02			
DO Name	DO Function Description	Trigger Method	Control Mode
SON	SON is activated when control power is applied the servo drive. The drive may or may not be ready to run as a fault / alarm condition may exist. Servo ON (SON) is "ON" with control power applied to the servo drive, there may be a fault condition or not. The servo is not ready to run. Servo ready (SRDY) is "ON" where the servo is ready to run, NO fault / alarm exists.	Level Triggered	All

Setting value: 0x03			
DO Name	DO Function Description	Trigger Method	Control Mode
ZSPD	ZSPD is activated when the drive senses the motor is equal to or below the Zero Speed Range setting as defined in parameter P1-38. For Example, at factory default ZSPD will be activated when the drive detects the motor rotating at speed at or below 10 r/min, ZSPD will remain activated until the motor speed increases above 10 r/min.	Level Triggered	All

Setting value: 0x04			
DO Name	DO Function Description	Trigger Method	Control Mode
TSPD	TSPD is activated once the drive has detected the motor has reached the Target Rotation Speed setting as defined in parameter P1-39. TSPD will remain activated until the motor speed drops below the Target Rotation Speed.	Level Triggered	All

Chapter 8 Servo Parameters

ASDA-A2

Setting value: 0x05

DO Name	DO Function Description	Trigger Method	Control Mode
TPOS	<ol style="list-style-type: none"> When the drive is in PT mode, TPOS will be activated when the position error is equal and below the setting value of P1-54. When the drive is in PR mode, TPOS will be activated when the drive detects that the position of the motor is in a -P1-54 to +P1-54 band of the target position. 	Level Triggered	PT, PR

Setting value: 0x06

DO Name	DO Function Description	Trigger Method	Control Mode
TQL	TQL is activated when the drive has detected that the motor has reached the torques limits set by either the parameters P1-12 ~ P1-14 of via an external analog voltage.	Level Triggered	All, except T, Tz

Setting value: 0x07

DO Name	DO Function Description	Trigger Method	Control Mode
ALRM	ALRM is activated when the drive has detected a fault condition. (However, when Reverse limit error, Forward limit error, Emergency stop, Serial communication error, and Undervoltage these fault occur, WARN is activated first.)	Level Triggered	All

Setting value: 0x08

DO Name	DO Function Description	Trigger Method	Control Mode
BRKR	<p>Electromagnetic brake control. BRKR is activated (Actuation of motor brake). (Please refer to parameters P1-42 ~ P1-43)</p>	Level Triggered	All

Setting value: 0x09

DO Name	DO Function Description	Trigger Method	Control Mode
HOME	<p>Homing completed. HOME is activated when the servo drive has detected that the "HOME" sensor (ORGP, digital input 0x24) has been detected.</p> <p>When power to the servo drive at the first time, this DO signal is OFF. After homing operation is completed, thi DO signal will be ON and continue being ON when the motor is running. It becomes OFF until the sytem detect that a position overflow occurs.</p> <p>When using PR command to trigger homing command, this DI signal will be OFF immediately. After homeing operation is completed, it becomes ON again.</p>	Level Triggered	PR

Setting value: 0x10

DO Name	DO Function Description	Trigger Method	Control Mode
OLW	<p>Output overload warning. OLW is activated when the servo drive has detected that the motor has reached the output overload time set by parameter P1-56.</p> <p>t_{OL} = Permissible Time for Overload x setting value of P1-56</p> <p>When overload accumulated time (continuously overload time) exceeds the value of t_{OL}, the overload warning signal will output, i.e. DO signal, OLW will be ON. However, if the accumulated overload time (continuous overload time) exceeds the permissible time for overload, the overload alarm (AL006) will occur.</p> <p>For example:</p> <p>If the setting value of parameter P1-56 (Output Overload Warning Time) is 60%, when the permissible time for overload exceeds 8 seconds at 200% rated output, the overload fault (AL006) will be detected and shown on the LED display.</p> <p>At this time, $t_{OL} = 8 \times 60\% = 4.8$ seconds</p> <p>Result:</p> <p>When the drive output is at 200% rated output and the drive is continuously overloaded for 4.8 seconds, the overload warning signal will be ON (DO code is 0x10, i.e. DO signal OLW will be activated). If the drive is continuously overloaded for 8 seconds, the overload alarm will be detected and shown on the LED display (AL006). Then, Servo Fault signal will be ON (DO signal ALRM will be activated).</p>	Level Triggered	PR

Chapter 8 Servo Parameters

ASDA-A2

Setting value: 0x11

DO Name	DO Function Description	Trigger Method	Control Mode
WARN	Servo warning activated. WARN is activated when the drive has detected Reverse limit error, Forward limit error, Emergency stop, Serial communication error, and Undervoltage these fault conditions.	Level Triggered	All

Setting value: 0x12

DO Name	DO Function Description	Trigger Method	Control Mode
OVF	Position command overflow. OVF is activated when the servo drive has detected that a position command overflows.	Level Triggered	All

Setting value: 0x13

DO Name	DO Function Description	Trigger Method	Control Mode
SNL (SCWL)	Reverse software limit. SNL is activated when the servo drive has detected that reverse software limit is reached.	Level Triggered	All

Setting value: 0x14

DO Name	DO Function Description	Trigger Method	Control Mode
SPL (SCCWL)	Forward software limit. SPL is activated when the servo drive has detected that forward software limit is reached.	Level Triggered	All

Setting value: 0x15

DO Name	DO Function Description	Trigger Method	Control Mode
CMD_OK	Internal position command completed output. CMD_OK is activated when the servo drive has detected that the internal position command has been completed. When executing PR command, this DI signal is OFF. After the execution of PR command is completed, this DI signal is ON. The output is used to indicate the internal position command has been completed and it does not indicate that the motor positioning is completed. For the signal of motor positioning completed, please refer to DO signal, TPOS.	Level Triggered	PR

ASDA-A2**Chapter 8 Servo Parameters****Setting value: 0x16**

DO Name	DO Function Description	Trigger Method	Control Mode
CAP_OK	Capture operation completed output. CAP_OK is activated when the servo drive has detected that capture operation has been completed.	Level Triggered	PR

Setting value: 0x17

DO Name	DO Function Description	Trigger Method	Control Mode
MC_OK	Motion control completed output. MC_OK is activated when CMD_OK and TPOS are both ON. It indicates MC_OK is activated only when the servo drive has detected that the position command has been given and the positioning has been completed also. If only CMD_OK or TPOS is ON, MC_OK will not be activated.	Level Triggered	PR

Setting value: 0x18

DO Name	DO Function Description	Trigger Method	Control Mode
CAM_AREA	CAM_AREA is activated when the servo drive has detected the master position of E-Cam (electronic CAM) is within the setting area. Please note: ASDA-A2 series L type models does not provide Electronic Cam (E-Cam) function.	Level Triggered	PR

Setting value: 0x19

DO Name	DO Function Description	Trigger Method	Control Mode
SP_OK	Speed reached output. SP_OK will be activated when the speed error is equal and below the setting value of P1-47.	Level Triggered	S, Sz

Setting value: 0x30

DO Name	DO Function Description	Trigger Method	Control Mode
SDO_0	Output the status of bit00 of P4-06.	Level Triggered	All

Chapter 8 Servo Parameters

ASDA-A2

Setting value: 0x31

DO Name	DO Function Description	Trigger Method	Control Mode
SDO_1	Output the status of bit01 of P4-06.	Level Triggered	All

Setting value: 0x32

DO Name	DO Function Description	Trigger Method	Control Mode
SDO_2	Output the status of bit02 of P4-06.	Level Triggered	All

Setting value: 0x33

DO Name	DO Function Description	Trigger Method	Control Mode
SDO_3	Output the status of bit03 of P4-06.	Level Triggered	All

Setting value: 0x34

DO Name	DO Function Description	Trigger Method	Control Mode
SDO_4	Output the status of bit04 of P4-06.	Level Triggered	All

Setting value: 0x35

DO Name	DO Function Description	Trigger Method	Control Mode
SDO_5	Output the status of bit05 of P4-06.	Level Triggered	All

Setting value: 0x36

DO Name	DO Function Description	Trigger Method	Control Mode
SDO_6	Output the status of bit06 of P4-06.	Level Triggered	All

Setting value: 0x37

DO Name	DO Function Description	Trigger Method	Control Mode
SDO_7	Output the status of bit07 of P4-06.	Level Triggered	All

ASDA-A2**Chapter 8 Servo Parameters****Setting value: 0x38**

DO Name	DO Function Description	Trigger Method	Control Mode
SDO_8	Output the status of bit08 of P4-06.	Level Triggered	All

Setting value: 0x39

DO Name	DO Function Description	Trigger Method	Control Mode
SDO_9	Output the status of bit09 of P4-06.	Level Triggered	All

Setting value: 0x3A

DO Name	DO Function Description	Trigger Method	Control Mode
SDO_A	Output the status of bit10 of P4-06.	Level Triggered	All

Setting value: 0x3B

DO Name	DO Function Description	Trigger Method	Control Mode
SDO_B	Output the status of bit11 of P4-06.	Level Triggered	All

Setting value: 0x3C

DO Name	DO Function Description	Trigger Method	Control Mode
SDO_C	Output the status of bit12 of P4-06.	Level Triggered	All

Setting value: 0x3D

DO Name	DO Function Description	Trigger Method	Control Mode
SDO_D	Output the status of bit13 of P4-06.	Level Triggered	All

Setting value: 0x3E

DO Name	DO Function Description	Trigger Method	Control Mode
SDO_E	Output the status of bit14 of P4-06.	Level Triggered	All

Setting value: 0x3F

DO Name	DO Function Description	Trigger Method	Control Mode
SDO_F	Output the status of bit15 of P4-06.	Level Triggered	All

**NOTE**

-
- 1) When P2-18 to P2-22 is set to 0, it indicates output function is disabled.

Chapter 9 Communications

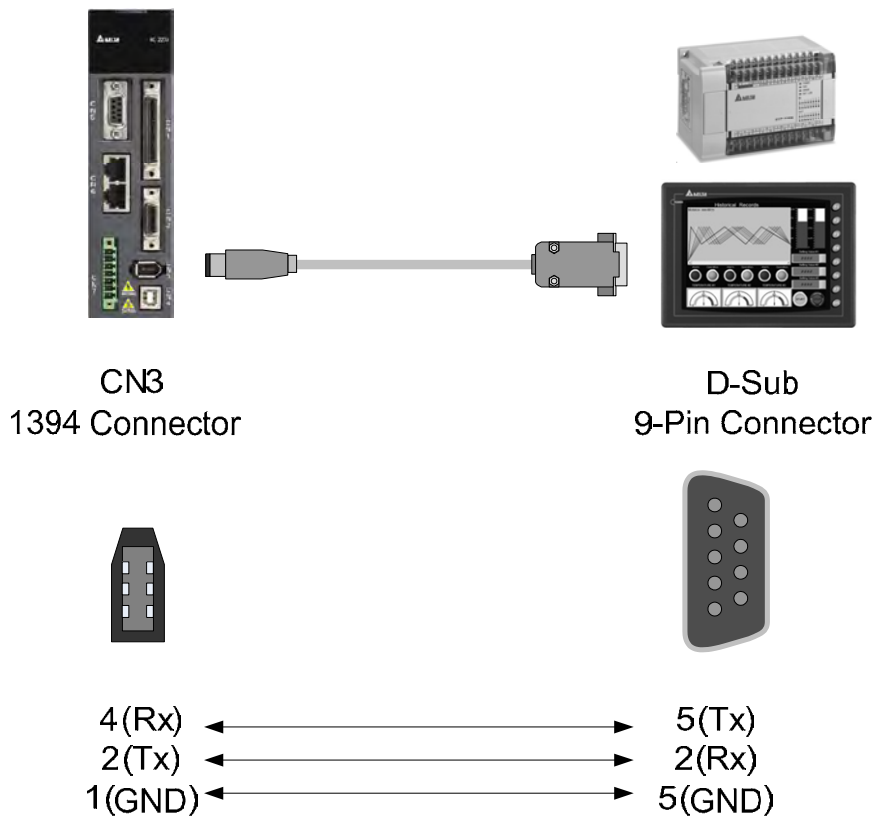
9.1 RS-485 & RS-232 Communication Hardware Interface

The ASDA-A2 series servo drives support RS-485 and RS-232 serial communication. All aspects of control, operation and monitoring as well as programming of the controller can be achieved via communication. However, only one communication mode can be used at a time. Users can select the desired communication mode via parameter P3-05.

Please refer to the following sections for connections and limitations.

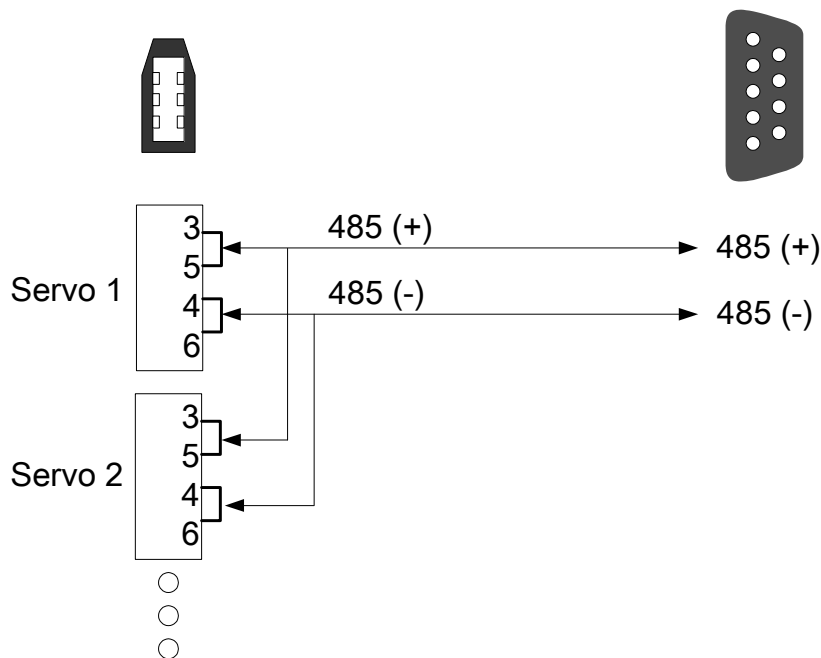
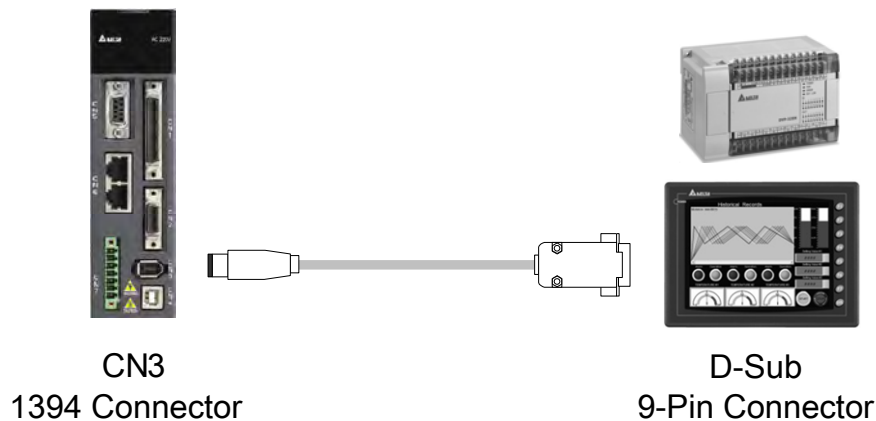
RS-232

■ Configuration



NOTE

- 1) Recommended maximum cable length is 15m (50ft.). Please note, RFI / EME noise should be kept to a minimum, communication cable should be kept apart from high voltage wires. If a transmission speed of 38400 bps or greater is required, the maximum length of the communication cable is 3m (9.84ft.) which will ensure the correct and desired baud rate.
- 2) The number shown in the previous figure indicates the terminal number of each connector.


RS-485**■ Configuration****NOTE**

- 1) The maximum cable length is 100m (39.37inches) when the servo drive is installed in a location where there are only a few interferences. Please note, RFI / EME noise should be kept to a minimum, communication cable should kept apart from high voltage wires. If a transmission speed of 38400 bps or greater is required, the maximum length of the communication cable is 15m (50ft.) which will ensure the correct and desired baud rate.
- 2) The number shown in the pervious figure indicates the terminal number of each connector.
- 3) The power supply should provide a +12V and higher DC voltage.
- 4) Please use a REPEATER if more than 32 synchronous axes are required. Maximum 254 servo drives can be connected.
- 5) For the terminal identification of CN3, please refer to Section 3.5.

9.2 Communication Parameters


The following four communication parameters, P3-00 (Communication Address Setting), P3-01 (Transmission Speed), P3-02 (Communication Protocol) and P3-05 (Communication Mode) are essential and must be set for the communication between the master (PC, etc.) and the AC servo drive. The other communication parameters, such as P3-03 (Transmission Fault Treatment), P3-04 (Communication Time Out Detection), P3-06 (Digital Input Communication Function), P3-07 (Communication Response Delay Time) and P3-08 (Monitor Mode) are for advanced communication settings. For the descriptions of all communication parameters, please refer to the Chapter 8.

P3-00 0300H 0301H Communication Address Setting	Default: 0x7F			
	Range: 0x01 ~ 0x7F			
	Settings (Hexadecimal):			
Display	0	0	Y	X
Range	-	-	0 ~ 7	0 ~ F


 When using RS-232/485 and CANbus communication, this parameter P3-00 is used set the communication address in hexadecimal format. If the AC servo drive is controlled by RS-232/485 communication, each drive (or device) must be uniquely identified. One servo drive only can set one address. If the address is duplicated, there will be a communication fault. This address is an absolute address which represents the servo drive on a RS-232/485 or CANbus network.

P3-01 0302H 0303H Transmission Speed	Default: 0x0203			
	Range: 0x0000 ~ 0x0405			
	Settings (Hexadecimal):			
Display	0	Z	Y	X
COM Port	-	CAN	-	RS-232/485
Range	0	0 ~ 4	0	0 ~ 5
X: Baud rate setting		Y: Reserved. Must be set to 0.		
0: 4800		Z: Communication speed setting		
1: 9600		0: 125 Kbit/s		
2: 19200		1: 250 Kbit/s		
3: 38400		2: 500 Kbit/s		
4: 57600		3: 750 Kbit/s		
5: 115200		4: 1.0 Mbit/s		
Please note:				
1. When setting this parameter via CANopen communication, only the setting of Z (communication speed setting) can be set. The other settings cannot be set.				
2. The communication speed for USB is 1.0Mbit/s and cannot be changed.				

<p>P3-02 0304H 0305H Communication Protocol</p>	<p>Default: 6 Range: 0~8 Settings: 0: Modbus ASCII mode, <7, N,2> 1: Modbus ASCII mode, <7,E,1 > 2: Modbus ASCII mode, <7,O,1> 3: Modbus ASCII mode, <8,N,2 > 4: Modbus ASCII mode, <8,E,1> 5: Modbus ASCII mode, <8,O,1> 6: Modbus RTU mode, <8,N,2> 7: Modbus RTU mode, <8,E,1> 8: Modbus RTU mode, <8,O,1></p>
---	---

 This parameter P3-02 is used to set the communication protocol. The alphanumeric characters represent the following: 7 or 8 is the number of data bits; N, E or O refers to the parity bit, Non, Even or Odd; the 1 or 2 is the numbers of stop bits.

<p>P3-05 030AH 030BH Communication Mode</p>	<p>Communication selection: Default: 0 Range: 0x00 ~ 0x01 Settings: 0: RS-232 1: RS-485</p>
---	---

 Multiple communication modes RS232 and RS-485 cannot be used within one communication ring.

9.3 MODBUS Communication Protocol

When using RS-232/485 serial communication interface, each ASDA-A2 series AC servo drive has a pre-assigned communication address specified by parameter "P3-00". The computer then controls each AC servo drive according to its communication address. ASDA-A2 series AC servo drives can be set up to communicate on a MODBUS network using one of the following modes: ASCII (American Standard Code for Information Interchange) or RTU (Remote Terminal Unit). Users can select the desired mode along with the serial port communication protocol in parameter "P3-02".

■ Code Description

ASCII Mode:

When AC servo drives are set up to communicate on a MODBUS network using ASCII (American Standard Code for Information Interchange) mode, each 8-bit data in a message is sent as two ASCII characters between the master and the slave. For example, a 1-byte data: 64 Hex, shown as '64' in ASCII, consists of '6' (36Hex) and '4' (34Hex).

ASCII Characters:

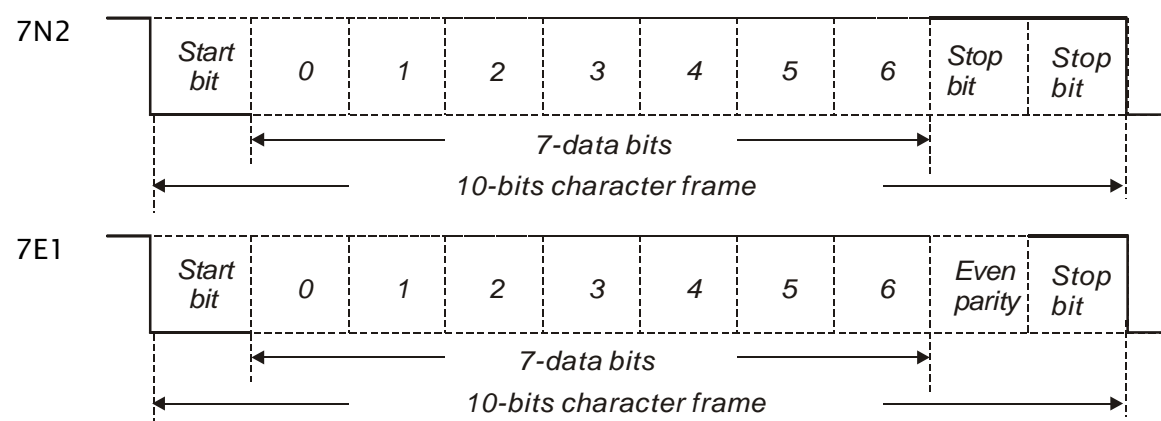
Character	'0'	'1'	'2'	'3'	'4'	'5'	'6'	'7'
ASCII code	30H	31H	32H	33H	34H	35H	36H	37H
Character	'8'	'9'	'A'	'B'	'C'	'D'	'E'	'F'
ASCII code	38H	39H	41H	42H	43H	44H	45H	46H

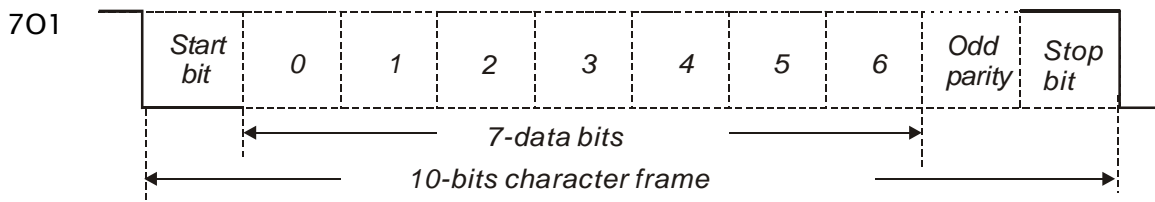
RTU Mode:

When AC servo drives are set up to communicate on a MODBUS network using RTU (Remote Terminal Unit) mode, each 8-bit data is the combination of two 4-bit hexadecimal characters. For example, a 1-byte data: 64 Hex. Comparing to ASCII mode, the transmission speed of RTU mode is better.

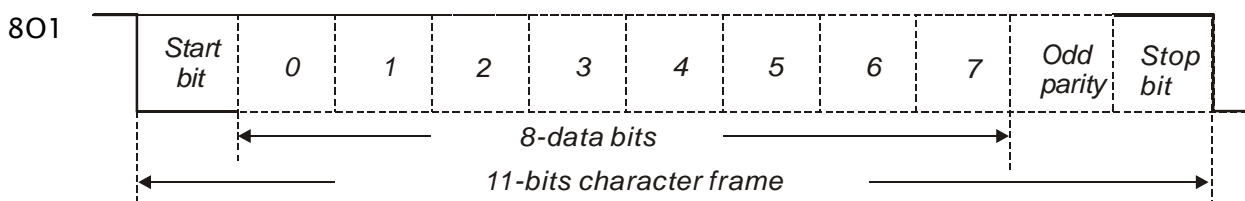
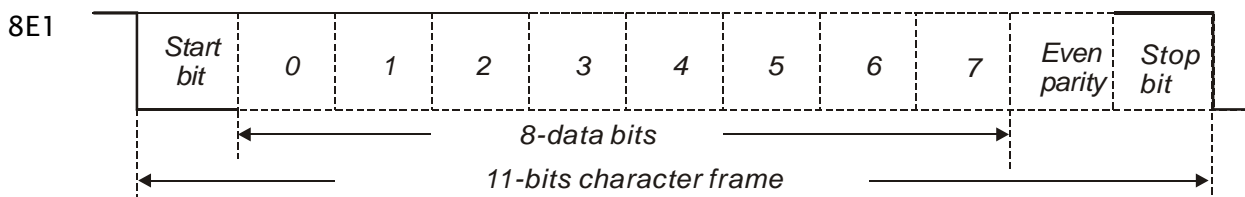
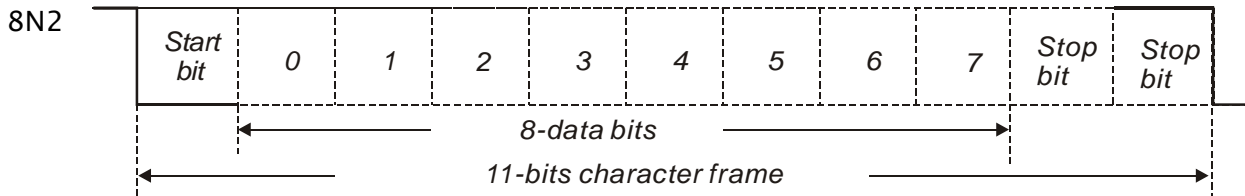
■ Data Format

10-bit character frame (For 7-bit character)





11-bit character frame (For 8-bit character)



■ **Communication Protocol**

ASCII Mode:

Start	Start character ': ' (3AH)
Slave Address	Communication address: 1-byte consists of 2 ASCII codes
Function	Function code: 1-byte consists of 2 ASCII codes
Data (n-1)	Contents of data: n word = n x 2-byte consists of n x 4 ASCII codes n ≤ 10
.....	
Data (0)	
LRC	Error checking: 1-byte consists of 2 ASCII codes
End 1	End code 1: (0DH)(CR)
End 0	End code 0: (0AH)(LF)

The communication protocol of ASCII mode starts from a start character ': ' (3AH). ADR is 1-byte consists of 2 ASCII codes. CR (Carriage Return) and LF (Line Feed) is a special sequence of characters signifying the end. There are communication address, function code, contents of data and LRC (Longitudinal Redundancy Check) between Start and End.

RTU Mode:

Start	A silent interval of more than 10ms
Slave Address	Communication address: 1-byte
Function	Function code: 1-byte
Data (n-1)	Contents of data: n word = n x 2-byte, $n \leq 12$
.....	
Data (0)	
CRC	Error checking: 1-byte
End 1	A silent interval of more than 10ms

The communication protocol of RTU mode starts from a signal of silent interval and ends at a signal of silent interval as well. There are communication address, function code, contents of data and CRC (Cyclical Redundancy Check) between Start and End.

The format of data characters depends on the function code. The available function codes and examples for AC servo drive are described as follows:

Example 1:**Function code: 03H, read N words (The maximum value of N is 10)**

For example, reading continuous 2 words from starting address 0200H of AC servo drive. In the response message (Slave), the content of starting data address 0200H is 00B1H and the content of second data address 0201H is 1F40H.

ASCII Mode:**Command message (Master):**

Start	‘.’
Slave Address	‘0’
	‘1’
Function	‘0’
	‘3’
Starting data address	‘0’
	‘2’
	‘0’
	‘0’
Number of data (In Word)	‘0’
	‘0’
	‘0’
	‘2’
LRC Check	‘F’
	‘8’
End 1	(0DH)(CR)
End 0	(0AH)(LF)

Response message (Slave):

Start	‘.’
Slave Address	‘0’
	‘1’
Function	‘0’
	‘3’
Number of data (In Byte)	‘0’
	‘4’
Content of starting data address 0200H	‘0’
	‘0’
	‘B’
Content of second data address 0201H	‘1’
	‘F’
	‘4’
LRC Check	‘0’
	‘E’
LRC Check	‘8’
	‘8’
End 1	(0DH)(CR)
End 0	(0AH)(LF)

RTU Mode:**Command message (Master):**

Slave Address	01H
Function	03H
Starting data address	02H (High)
	00H (Low)
Number of data (In Word)	00H
	02H
CRC Check Low	C5H (Low)
CRC Check High	B3H (High)

Response message (Slave):

Slave Address	01H
Function	03H
Number of data (In Byte)	04H
Content of starting data address 0200H	00H (High)
	B1H (Low)
Content of second data address 0201H	1FH (High)
	40H (Low)
CRC Check Low	A3H (Low)
CRC Check High	D4H (High)

Please note:

In RTU mode, a silent interval of more than 10ms is needed before and after transmission.

Example 2:**Function code: 06H, write 1 word**

For example, writing 100 (0064H) to starting data address 0200H. The slave will send the response message to the master after writing operation is completed.

ASCII Mode:**Command message (Master):**

Start	‘.’
Slave Address	‘0’
	‘1’
Function	‘0’
	‘6’
Starting data address	‘0’
	‘2’
	‘0’
	‘0’
Content of data	‘0’
	‘0’
	‘6’
	‘4’
LRC Check	‘9’
	‘3’
End 1	(0DH)(CR)
End 0	(0AH)(LF)

Response message (Slave):

Start	‘.’
Slave Address	‘0’
	‘1’
Function	‘0’
	‘6’
Starting data address	‘0’
	‘2’
	‘0’
	‘0’
Content of data	‘0’
	‘0’
	‘6’
	‘4’
LRC Check	‘9’
	‘3’
End 1	(0DH)(CR)
End 0	(0AH)(LF)

RTU Mode:**Command message (Master):**

Address	01H
Slave Function	06H
Starting data address	02H (High)
	00H (Low)
Content of data	00H (High)
	64H (Low)
CRC Check Low	89H (Low)
CRC Check High	99H (High)

Response message (Slave):

Address	01H
Slave Function	06H
Starting data address	02H (High)
	00H (Low)
Content of data	00H (High)
	64H (Low)
CRC Check Low	89H (Low)
CRC Check High	99H (High)

Please note:

In RTU mode, a silent interval of more than 10ms is needed before and after transmission.

Example 3:**Function code: 10H, write N words (The maximum value of N is 10)**

For example, writing continuous 2 words into starting address 0112H of AC servo drive. The content of first data address is 0BB8H and the content of second data address is 0000H.

ASCII Mode:**Command message (Master):**

Start	‘.’
Slave Address	‘0’
	‘1’
Function	‘1’
	‘0’
Starting data address	‘0’
	‘1’
	‘1’
	‘2’
Number of data (In Word)	‘0’
	‘0’
	‘0’
	‘2’
Number of data (In Byte)	‘0’
	‘4’
Content of first data address	‘0’
	‘B’
	‘B’
	‘8’
Content of second data address	‘0’
	‘0’
	‘0’
	‘0’
LRC Check	‘1’
	‘3’
End 1	(0DH)(CR)
End 0	(0AH)(LF)

Response message (Slave):

Start	‘.’
Slave Address	‘0’
	‘1’
Function	‘1’
	‘0’
Starting data address	‘0’
	‘1’
	‘1’
	‘2’
Number of data	‘0’
	‘0’
	‘0’
	‘2’
LRC Check	‘D’
	‘A’
End 1	(0DH)(CR)
End 0	(0AH)(LF)

RTU Mode:**Command message (Master):**

Slave Address	01H
Function	10H
Starting data address	01H (High)
	12H (Low)
Number of data (In Word)	00H (High)
	02H (Low)
Number of data (In Byte)	04H
Content of first data address	0BH (High)
	B8H (Low)
Content of second data address	00H (High)
	00H (Low)
CRC Check Low	FCH (Low)
CRC Check High	EBH (High)

Response message (Slave):

Slave Address	01H
Function	10H
Starting data address	01H (High)
	12H (Low)
Number of data (In Word)	00H (High)
	02H (Low)
CRC Check Low	E0H (Low)
CRC Check High	31H (High)

Please note:

In RTU mode, a silent interval of more than 10ms is needed before and after transmission.

■ LRC and CRC Error Checking

ASCII mode adopts LRC (Longitudinal Redundancy Check) and RTU mode adopts CRC (Cyclical Redundancy Check)

LRC (ASCII Mode):

LRC (Longitudinal Redundancy Check) is calculated by summing up, module 256, the values of the bytes from Slave address to last data character then calculating the hexadecimal representation of the 2's-complement negation of the sum.

For example, reading 1 word from address 05C4H of the AC servo drive with address 7FH.

Start	':'
Slave address	'7'
	'F'
Function	'0'
	'3'
Starting data address	'0'
	'5'
	'C'
	'4'
Number of data	'0'
	'0'
	'0'
	'1'
LRC Check	'B'
	'4'
End 1	(0DH)(CR)
End 0	(0AH)(LF)

$7FH + 03H + 05H + C4H + 00H + 01H = 14CH$, take 4CH only, the 2's complement negation of 4CH is B4H.

Hence, we can know that LRC CHK is 'B', '4'.

CRC (RTU Mode):

CRC (Cyclical Redundancy Check) is calculated by the following steps:

Step 1: Load a 16-bit register (called CRC register) with FFFFH.

Step 2: Exclusive OR the first 8-bit byte of the command message with the low order byte of the 16-bit CRC register, putting the result in the CRC register.

Step 3: Extract and examine the LSB. If the LSB of CRC register is 0, shift the CRC register one bit to the right. If the LSB of CRC register is 1, shift the CRC register one bit to the right, then Exclusive OR the CRC register with the polynomial value A001H.

Step 4: Repeat step 3 until eight shifts have been performed. When this is done, a complete 8-bit byte will have been processed, then perform step 5.

Step 5: Repeat step 2 to step 4 for the next 8-bit byte of the command message.

Continue doing this until all bytes have been processed. The final contents of the CRC register are the CRC value.

For example, reading 2 words from address 0101H of the AC servo drive with address 01H. The final content of the CRC register from ADR to last data character is 3794H, then the command message is shown as follows. What should be noticed is that 94H have to be transmitted before 37H.

Command Message	
ADR	01H
CMD	03H
Starting data address	01H (High)
	01H (Low)
Number of data (In Word)	00H (High)
	02H (Low)
CRC Check Low	94H (Low)
CRC Check High	37H (High)

Example

The following is an example of CRC generation using C language. The function takes two arguments:

unsigned char* data;

unsigned char length

The function returns the CRC value as a type of unsigned integer.

```

unsigned int crc_chk(unsigned char* data, unsigned char length) {
    int j;
    unsigned int reg_crc=0xFFFF;

    while( length-- ) {
        reg_crc^= *data++;
        for (j=0; j<8; j++) {
            if( reg_crc & 0x01 ) { /*LSB(bit 0 ) = 1 */
                reg_crc = (reg_crc >> 1)^0xA001;
            } else {
                reg_crc = (reg_crc>>1);
            }
        }
    }
    return reg_crc;
}

```

PC communication program example:

```

#include<stdio.h>
#include<dos.h>
#include<conio.h>
#include<process.h>
#define PORT 0x03F8    /* the address of COM 1 */
#define THR 0x0000
#define RDR 0x0000
#define BRDL 0x0000
#define IER 0x0001
#define BRDH 0x0001
#define LCR 0x0003
#define MCR 0x0004
#define LSR 0x0005
#define MSR 0x0006
unsigned char rdat[60];
/* read 2 data from address 0200H of ASD with address 1 */

```



```

unsigned char tdat[60]={'.', '0', '1', '0', '3', '0', '2', '0', '0', '0', '0', '2', 'F', '8', '\r', '\n'};
void main() {
int I;
outportb(PORT+MCR,0x08);          /* interrupt enable */
outportb(PORT+IER,0x01);          /* interrupt as data in */
outportb(PORT+LCR,( inportb(PORT+LCR) | 0x80 ));
/* the BRDL/BRDH can be access as LCR.b7 == 1 */
outportb(PORT+BRDL,12);
outportb(PORT+BRDH,0x00);
outportb(PORT+LCR,0x06);          /* set prorocol
                                   <7,E,1> = 1AH,          <7,O,1> = 0AH
                                   <8,N,2> = 07H          <8,E,1> = 1BH
                                   <8,O,1> = 0BH          */

for( I = 0; I<=16; I++ ) {
    while( !(inportb(PORT+LSR) & 0x20) ); /* wait until THR empty */
    outportb(PORT+THR,tdat[I]);          /* send data to THR */
}
I = 0;
while( !kbhit() ) {
    if( inportb(PORT+LSR)&0x01 ) { /* b0==1, read data ready */
        rdat[I++] = inportb(PORT+RDR); /* read data from RDR */
    }
}
}
}

```

9.4 Communication Parameter Write-in and Read-out

There are following 8 groups for parameters:

Group 1: Basic parameters	(example: P1-xx)
Group 2: Extension parameters	(example: P2-xx)
Group 3: Communication parameters	(example: P3-xx)
Group 4: Diagnosis parameters	(example: P4-xx)
Group 5: Motion control parameters	(example: P5-xx)
Group 6: PR definition parameters	(example: P6-xx)
Group 7: PR definition parameters	(example: P7-xx)

For a complete listing and description of all parameters, refer to Chapter 8.

Communication write-in parameters for ASDA-A2 series are including:

Group 0: All parameters except P0-00 ~ P0-01, P0-08 ~ P0-13 and P0-46

Group 1: P1-00 ~ P1-76

Group 2: P2-00 ~ P2-67

Group 3: P3-00 ~ P3-11

Group 4: All parameters except P4-00 ~ P4-04 and P4-08 ~ P4-09

Group 5: All parameters except P5-10, P5-16 and P5-76

Group 6: P6-00 ~ P6-99

Group 7: P7-00 ~ P7-27

NOTE

- 1) P3-01 After the new transmission speed is set, the next data will be written in new transmission speed.
- 2) P3-02 After the new communication protocol is set, the next data will be written in new communication protocol.
- 3) P4-05 JOG control of servo motor. For the description, refer to Chapter 8.
- 4) P4-06 Force output contact control. This parameter is for the users to test if DO (Digit output) is normal. User can set 1, 2, 4, 8, 16 to test DO1, DO2, DO3, DO4, DO5, respectively. After the test has been completed, please set this parameter to 0 to inform the drive that the test has been completed.
- 5) P4-10 Adjustment function selection. If user desires to change the settings of this parameter, user has to set the value of the parameter P2-08 to 20 (hexadecimal: 14H) first and then restart. After restarting, the settings of parameter P4-10 can become modified.

- 6) P4-11 ~ P4-21 These parameters are for offset adjustment. Do not change the factory default setting if not necessary. If the user desires to change the settings of these parameters, the user has to set the value of the parameter P2-08 to 22 (hexadecimal: 16H) first and then restart. After restarting, the settings of parameters P4-11 to P4-21 can become modified.

Communication read-out parameters for ASDA-A2 series are including:

Group 0: P0-00 ~ P0-46

Group 1: P1-00 ~ P1-76

Group 2: P2-00 ~ P2-67

Group 3: P3-00 ~ P3-11

Group 4: P4-00 ~ P4-23

Group 5: P5-00 ~ P5-99

Group 6: P6-00 ~ P6-99

Group 7: P7-00 ~ P7-27

Chapter 10 Troubleshooting

If a fault is detected on the servo motor or drive, a corresponding fault code will be shown on the drive's LED display. Fault codes can also be transmitted via communication, see P0-01 and P4-00 ~ P4-04 for display on controller or HMI.

10.1 Fault Messages Table

Servo Drive Fault Messages

Fault Messages		
Display	Fault Name	Fault Description
AL001	Overcurrent	Main circuit current is higher than 1.5 multiple of motor's instantaneous maximum current value.
AL002	Overvoltage	Main circuit voltage has exceeded its maximum allowable value.
AL003	Undervoltage	Main circuit voltage is below its minimum specified value.
AL004	Motor error	The motor does not match the drive. They are not correctly matched for size (power rating).
AL005	Regeneration error	Regeneration control operation is in error.
AL006	Overload	Servo motor and drive is overload.
AL007	Overspeed	Motor's control speed exceeds the limit of normal speed.
AL008	Abnormal pulse control command	Input frequency of pulse command exceeds the limit of its allowable setting value.
AL009	Excessive deviation	Position control deviation value exceeds the limit of its allowable setting value.
AL010	Reserved	
AL011	Encoder error	Pulse signal is in error.
AL012	Adjustment error	Adjusted value exceeds the limit of its allowable setting value when perform electrical adjustment.
AL013	Emergency stop activated	Emergency stop switch is activated.
AL014	Reverse limit switch error	Reverse limit switch is activated.
AL015	Forward limit switch error	Forward limit switch is activated.

Fault Messages		
Display	Fault Name	Fault Description
AL016	IGBT temperature error	The temperature of IGBT is over high.
AL017	Memory error	EE-PROM write-in and read-out is in error.
AL018	Encoder output error	The encoder output exceeds the rated output frequency.
AL019	Serial communication error	RS-232/485 communication is in error.
AL020	Serial communication time out	RS-232/485 communication time out.
AL021	Reserved	
AL022	Input power phase loss	One phase of the input power is loss.
AL023	Pre-overload warning	To warn that the servo motor and drive is going to overload. This alarm will display before ALM06. When the servo motor reach the setting value of P1-56, the motor will send a warning to the drive. After the drive has detected the warning, the DO signal OLV will be activated and this fault message will display.
AL024	Encoder initial magnetic field error	The magnetic field of the encoder U, V, W signal is in error.
AL025	Encoder internal error	The internal memory of the encoder is in error. An internal counter error is detected.
AL026	Encoder data error	An encoder data error is detected for three times.
AL030	Motor protection error	In order to protect the motor, this alarm will be activated when the setting value of P1-57 is reached after a period of time set by P1-58.
AL031	U,V,W wiring error	The wiring connections of U, V, W (for servo motor output) and GND (for grounding) are in error.
AL040	Full closed-loop excessive deviation	The position control deviation value of full closed-loop exceeds the specified limit.
AL099	DSP firmware upgrade	EE-PROM is not reset after the firmware version is upgraded. This fault can be cleared after setting P2-08 to 30 first, and then setting P2-08 to 28 next and restarting the servo drive.

CANopen Communication Fault Messages

Fault Messages		
Display	Fault Name	Fault Description
AL 185	CANbus error	CANbus off or Error Rx/Tx Counter exceeds 128.
AL 111	CANopen SDO receive buffer overrun	SDO Rx buffer overrun is detected (receive two or more SDO packets in 1 ms).
AL 112	CANopen PDO receive buffer overrun	PDO Rx buffer overrun is detected (receive two or more PDO (same COBID) packets in 1 ms).
AL 121	Index error occurs when accessing CANopen PDO object.	The specified Index in the message does not exist.
AL 122	Sub-index error occurs when accessing CANopen PDO object.	The specified Sub-index in the message does not exist.
AL 123	Data type (size) error occurs when accessing CANopen PDO object.	The data length in the message does not match the specified object.
AL 124	Data range error occurs when accessing CANopen PDO object.	The data in the message has exceeded the data range of the specified object.
AL 125	CANopen PDO object is read-only and write-protected.	The specified object in the message is read-only and write-protected (cannot be changed).
AL 126	CANopen PDO object does not support PDO.	The specified object in the message does not support PDO.
AL 127	CANopen PDO object is write-protected when Servo On.	The specified object in the message is write-protected (cannot be changed) when Servo On.
AL 128	Error occurs when reading CANopen PDO object from EE-PROM.	An error occurs when loading the default settings from EE-PROM at start-up. All CANopen objects return to their default settings automatically.
AL 129	Error occurs when writing CANopen PDO object into EE-PROM.	An error occurs when writing the current settings into EE-PROM.

Fault Messages		
Display	Fault Name	Fault Description
AL130	EE-PROM invalid address range	The amount of the data saved in EE-PROM has exceeded the space determined by the firmware. Maybe the firmware version has been upgraded, and it causes that the data of old firmware version saved in EE-PROM cannot be used.
AL131	EE-PROM checksum error	The data saved in EE-PROM has been damaged and all CANopen objects return to their default settings automatically.
AL132	Password error	The parameter is password protected when using CANopen communication to access the parameter. The users must enter the valid password to unlock the parameter.

Motion Control Fault Messages

Fault Messages		
Display	Fault Name	Fault Description
AL201	CANopen data initial error	An error occurs when loading data from EE-PROM.
AL213	Write parameter error: exceeds the limit of normal range.	Write parameter error occurs in PR mode: the setting value exceeds the limit of normal range.
AL215	Write parameter error: read only.	Write parameter error occurs in PR mode: the parameter is read only.
AL217	Write parameter error: parameter lock	Write parameter error occurs in PR mode: the parameter is write-protected (cannot be changed) when Servo On or the setting value is invalid.
AL219	Write parameter error: parameter lock	Write parameter error occurs in PR mode: the parameter is write-protected (cannot be changed) when Servo On or the setting value is invalid.
AL235	PR command overflow	In PR mode, this fault occurs when position command counter register overflowed and at this time an absolute position command is executed.
AL245	PR positioning time out	In PR mode, the execution time of positioning command exceeds its time limit.
AL249	Invalid PR path number	In PR mode, the valid range of PR path number is within 0~63. The path number is not within this range.
AL261	Index error occurs when accessing CANopen object.	The specified Index in the message does not exist.

Fault Messages		
Display	Fault Name	Fault Description
AL263	Sub-index error occurs when accessing CANopen object.	The specified Sub-index in the message does not exist.
AL265	Data type (size) error occurs when accessing CANopen object.	The data length in the message does not match the specified object.
AL267	Data range error occurs when accessing CANopen object.	The data in the message has exceeded the data range of the specified object.
AL269	CANopen object is read-only and write-protected.	The specified object in the message is read-only and write-protected (cannot be changed).
AL266	CANopen object does not support PDO.	The specified object in the message does not support PDO.
AL26d	CANopen object is write-protected when Servo On.	The specified object in the message is write-protected (cannot be changed) when Servo On.
AL26F	Error occurs when reading CANopen object from EE-PROM.	An error occurs when loading the default settings from EE-PROM at start-up. All CANopen objects return to their default settings automatically.
AL271	Error occurs when writing CANopen object into EE-PROM.	An error occurs when writing the current settings into EE-PROM.
AL273	EE-PROM invalid address range	The amount of the data saved in EE-PROM has exceeded the space determined by the firmware. Maybe the firmware version has been upgraded, and it causes that the data of old firmware version saved in EE-PROM cannot be used.
AL275	EE-PROM checksum error	The data saved in EE-PROM has been damaged and all CANopen objects return to their default settings automatically.
AL277	Password error	The parameter is password protected when using CANopen communication to access the parameter. The users must enter the valid password to unlock the parameter.
AL283	Forward software limit	Position command is equal to or more than forward software limit.

Fault Messages		
Display	Fault Name	Fault Description
AL285	Reverse software limit	Position command is equal to or less than forward software limit.
AL289	Position counter overflow	Position counter overflow occurs.
AL291	Servo Off error	Servo Off occurs during positioning (when the drive and motor are both running).
AL301	CANopen SYNC failed	The synchronous communication with the external controller has failed.
AL302	CANopen SYNC signal error	The CANopen SYNC signal is received too early.
AL303	CANopen SYNC time out	The CANopen SYNC signal is not received within the specified time.
AL304	CANopen IP command failed	Internal command of CANopen IP mode cannot be sent and received.
AL305	SYNC period error	Object 0x1006 data error. SYNC period 1006h value is invalid.
AL380	Position deviation alarm for digital output, MC_OK	After MC_OK is activated, when the digital output, TPOS is Off, the digital output, MC_OK becomes Off. For more detailed explanation, please refer to parameter P1-48 in Chapter 8.

 **NOTE**

- 1) If there is any unknown fault code that is not listed on the above table, please inform the distributor or contact with Delta for assistance.
- 2) For more information about the CANopen objects, please refer to CANopen Instruction Manual.

10.2 Potential Cause and Corrective Actions

Servo Drive Fault Messages

AL001 : Overcurrent

Potential Cause	Checking Method	Corrective Actions
Short-circuit at drive output (U, V, W)	<ol style="list-style-type: none"> 1. Check the wiring connections between drive and motor. 2. Check if the wire is short-circuited. 	Repair the short-circuited and avoid metal conductor being exposed.
Motor wiring error	Check if the wiring steps are all correct when connecting motor to drive.	Follow the wiring steps in the user manual to reconnect wiring.
IGBT error	Heat sink overheated	Please contact your distributor for assistance or contact with Delta.
Control parameter setting error	Check if the setting value exceeds the factory default setting.	Set the setting back to factory default setting and then reset and adjust the parameter setting again.
Control command setting error	Check if the control input command is unstable (too much fluctuation).	<ol style="list-style-type: none"> 1. Ensure that input command frequency is stable (too much fluctuation). 2. Activate filter function.

AL002 : Overvoltage

Potential Cause	Checking Method	Corrective Actions
The main circuit voltage has exceeded its maximum allowable value.	Use voltmeter to check whether the input voltage falls within the rated input voltage. (For voltage specification, please refer to section 12.1 in Chapter12.)	Use correct power supply or stabilizing power or using series transformer.
Input power error (Incorrect power input)	Use voltmeter to check whether the input voltage is within the specified limit.	Use correct power supply or stabilizing power or using series transformer.
The hardware of the servo drive is damaged.	Use voltmeter to ensure that the main circuit input voltage falls within the specified limit,	If the error does not clear even if the main circuit input voltage falls within the specified limit, please contact your distributor for assistance or contact with Delta.

AL003 : Undervoltage

Potential Cause	Checking Method	Corrective Actions
The main circuit voltage is below its minimum specified value.	Check whether the wiring of main circuit input voltage is normal.	Reconfirm voltage wiring.
No input voltage at main circuit.	Use voltmeter to check whether input voltage at main circuit is normal.	Reconfirm power switch.
Input power error (Incorrect power input)	Use voltmeter to check whether the input voltage is within the specified limit.	Use correct power supply or stabilizing power or using series transformer.

AL004 : Motor error

Potential Cause	Checking Method	Corrective Actions
Encoder is damaged.	Check the encoder for the damage.	Replace the motor.
Encoder is loose.	Examine the encoder connector.	Install the motor again.
The type of the servo motor is incorrect.	Check if the servo drive and servo motor are not correctly matched for size (power rating).	Replace the motor.

AL005 : Regeneration error

Potential Cause	Checking Method	Corrective Actions
Regenerative resistor is not connected or the value of the regenerative resistor is too low.	Check the wiring connection of regenerative resistor.	Reconnect regenerative resistor or calculate the value of the regenerative resistor.
The parameter P1-53 is not set to zero when the regenerative resistor is not in use.	Ensure the parameter P1-53 is set to zero.	Set the parameter P1-53 to zero when the regenerative resistor is not in use.
Parameter setting is in error	Confirm the parameter settings of P1-52 and P1-53, and specifications of regenerative resistor.	Correctly reset parameter settings and the specifications of regenerative resistor again.

AL006 : Overload

Potential Cause	Checking Method	Corrective Actions
The drive has exceeded its rated load during continuous operation.	Check if the drive is overloaded. The users can set parameter P0-02 (Drive Fault Code) to 11 and monitor if the value of the average torque [%] exceeds 100% always.	Increase motor capacity or reduce load.
Control system parameter setting is incorrect.	1.Check if there is mechanical vibration 2.Accel/Decel time setting is too fast.	1.Adjust gain value of control circuit. 2.Decrease Accel/Decel time setting.
The wiring of drive and encoder is in error.	Check the wiring of U, V, W and encoder.	Ensure all wiring is correct.
The encoder of the motor is damaged.	Please contact your distributor for assistance or contact with Delta.	

AL007 : Overspeed

Potential Cause	Checking Method	Corrective Actions
Speed input command is not stable (too much fluctuation).	Use signal detector to detect if input signal is abnormal.	Ensure that input command frequency is stable (not fluctuate too much) and activate filter function.
Over-speed parameter setting is defective.	Check if over-speed parameter setting value is too low.	Correctly set over-speed parameter setting (P2-34).

AL008 : Abnormal pulse control command

Potential Cause	Checking Method	Corrective Actions
Pulse command frequency is higher than rated input frequency.	Use pulse frequency detector to measure input frequency.	Correctly set the input pulse frequency.

AL009 : Excessive deviation

Potential Cause	Checking Method	Corrective Actions
Maximum deviation parameter setting is too small.	Check the maximum deviation parameter setting and observe the position error value when the motor is running.	Increases the parameter setting value of P2-35.
Gain value is too small.	Check for proper gain value.	Correctly adjust gain value.
Torque limit is too low.	Check torque limit value.	Correctly adjust torque limit value.
There is an overload.	Check for overload condition.	Reduce external applied load or re-estimate the motor capacity.

AL010 : Reserved**AL011** : Encoder error (Position detector fault)

Potential Cause	Checking Method	Corrective Actions
The wiring of encoder is in error.	1.Check if all wiring is correct. 2.Check if the users conduct the wiring by the wiring information in the user manual.	Ensure all wiring is correct.
Encoder is loose	Examine the encoder connector (CN2).	Install the motor again.
The wiring of encoder is defective.	Check if all connections are tight.	Conduct the wiring again.
Encoder is damage	Check the motor for the damage.	Replace the motor.

AL012 : Adjustment error

Potential Cause	Checking Method	Corrective Actions
The analog input contact does not go back to zero.	Measure if the voltage of the analog input contact is the same as the voltage of the ground.	Correctly ground the analog input contact.
The detection device is damaged.	Reset the power supply.	If the error does not clear after resetting the power supply, please contact your distributor for assistance or contact with Delta.

AL013 : Emergency stop activated

Potential Cause	Checking Method	Corrective Actions
Emergency stop switch is activated.	Check if emergency stop switch is On or Off.	Activate emergency stop switch.

AL014 : Reverse (CWL) limit switch error

Potential Cause	Checking Method	Corrective Actions
Reverse limit switch is activated.	Check if reverse limit switch is On or Off.	Activate reverse limit switch.
Servo system is not stable.	Check the value of control parameter setting and load inertia.	Modify parameter setting and re-estimate motor capacity.

AL015 : Forward (CCWL) limit switch error

Potential Cause	Checking Method	Corrective Actions
Forward limit switch is activated.	Check if forward limit switch is On or Off.	Activate forward limit switch.
Servo system is not stable.	Check the value of control parameter setting and load inertia.	Modify parameter setting and re-estimate motor capacity.

AL016 : IGBT temperature error

Potential Cause	Checking Method	Corrective Actions
The drive has exceeded its rated load during continuous operation.	Check if there is overload or the motor current is too high.	Increase motor capacity or reduce load.
Short-circuit at drive output.	Check the drive input wiring.	Ensure all wiring is correct.

AL017 : Memory error

Potential Cause	Checking Method	Corrective Actions
Parameter data error when writing into EE-PROM.	Examine the parameter settings. Please do the following steps: 1.Press SHIFT key on the drive keypad, and examine the parameter shown on LED display. 2.If E320A is displayed (in hexadecimal format), it indicates it is parameter P2-10. Please examine the parameter settings of P2-10. 3.If E3610 is displayed (in hexadecimal format), it indicates it is parameter P6-16. Please examine the parameter settings of P6-16.	1.If this fault occurs when power is applied to the drive, it indicates that the setting value of one parameter has exceeded the specified range. Correct the setting value of the parameter to clear the fault and restart the servo drive. 2.If this fault occurs during normal operation, it indicates that the error occurs when writing data into EE-PROM. Turn ARST (DI signal) ON to clear the fault or restart the servo drive.
The setting value of hidden parameter is in error.	Press SHIFT key on the drive keypad and examine if E100X is displayed on LED display.	If this fault occurs when resetting the parameter settings, it indicates that the servo drive type is not set correctly. Correctly set the servo drive type again.
Data in EE-PROM is damaged.	Press SHIFT key on the drive keypad and examine if E0001 is displayed on LED display.	If this fault occurs when power is applied to the drive, it indicates that the data in EE-RPM is damaged or there is no data in EE-PROM. Please contact your distributor for assistance or contact with Delta.

AL018 : Encoder output error

Potential Cause	Checking Method	Corrective Actions
Encoder itself or the wiring of encoder is in error.	Check if the recent fault records (P4-00 ~ P4-05) display on the drive keypad in accordance with the fault codes AL011, AL024, AL025 and AL026.	Perform the corrective actions as described in AL011, AL024, AL025 and AL026.
The output frequency for pulse output may exceed the limit of its allowable setting value.	Check if the following conditions occur: Condition 1: Motor speed is above the value set by P1-76. Condition 2: $\frac{\text{Motor Speed}}{60} \times P1-46 \times 4 > 19.8 \times 10^6$	Correctly set P1-76 and P1-46. 1. Ensure that the motor speed is below the value set by P1-76. 2. $\frac{\text{Motor Speed}}{60} \times P1-46 \times 4 < 19.8 \times 10^6$

AL019 : Serial communication error

Potential Cause	Checking Method	Corrective Actions
Communication parameter setting is defective.	Check the communication parameter setting.	Correctly set parameter setting.
Communication address is incorrect.	Check the communication address.	Correctly set communication address.
Communication value is incorrect.	Check the communication value.	Correctly set communication value.

AL020 : Serial communication time out

Potential Cause	Checking Method	Corrective Actions
Setting value in time out parameter is not correct.	Check communication time out parameter setting.	Correctly set P3-07.
Not receiving communication command for a long time.	Check whether communication cable is loose or broken.	Tighten the communication cable, make sure the communication cable is not damaged and ensure all wiring is correct.

AL021 : Reserved**AL022** : Input power phase loss

Potential Cause	Checking Method	Corrective Actions
Control power supply is in error.	Check the power cable and connections of R, S, T. Check whether the power cable is loose or the possible loss of phase on input power.	If the fault does not clear even when the three-phase power is connected correctly, please contact your distributor for assistance or contact with Delta.

AL023 : Pre-overload warning

Potential Cause	Checking Method	Corrective Actions
The drive is going to overload.	<ol style="list-style-type: none"> 1. Check the load condition of the servo motor and drive. 2. Check the setting value of P1-56. Check whether the setting value of P1-56 is too small. 	<ol style="list-style-type: none"> 1. Please refer to the correction actions of AL006. 2. Increase the setting value of P1-56 or set P1-56 to 100 and above.

AL024 : Encoder initial magnetic field error

Potential Cause	Checking Method	Corrective Actions
The magnetic field of the encoder U, V, W signal is in error.	<ol style="list-style-type: none"> 1. Check if the servo motor is properly grounded. 2. Check if the encoder signal cables are placed in separate conduits from the cables connected to R, S, T and U, V, W terminals to prevent the interference. 3. Check if the shielded cables are used when performing encoder wiring. 	If the error does not clear after each checking is done, please contact your distributor for assistance or contact with Delta.

AL025 : Encoder internal error

Potential Cause	Checking Method	Corrective Actions
The internal memory of the encoder is in error. An encoder counter error occurs.	<ol style="list-style-type: none"> 1. Check if the servo motor is properly grounded. 2. Check if the encoder signal cables are placed in separate conduits from the cables connected to R, S, T and U, V, W terminals to prevent the interference. 3. Check if the shielded cables are used when performing encoder wiring. 	<ol style="list-style-type: none"> 1. Please connect the grounding (green color) of U, V, W terminal to the heatsink of the servo drive. 2. Ensure that the encoder signal cables are placed in separate conduits from the cables connected to R, S, T and U, V, W terminals to prevent the interference. 3. Please use shielded cables for Encoder wiring. 4. If the error does not clear after all the above actions are done, please contact your distributor for assistance or contact with Delta.

AL026 : Encoder data error

Potential Cause	Checking Method	Corrective Actions
An encoder data error occurs for three times.	<ol style="list-style-type: none"> 1. Check if the servo motor is properly grounded. 2. Check if the encoder signal cables are placed in separate conduits from the cables connected to R, S, T and U, V, W terminals to prevent the interference. 3. Check if the shielded cables are used when performing encoder wiring. 	<ol style="list-style-type: none"> 1. Please connect the grounding (green color) of U, V, W terminal to the heatsink of the servo drive. 2. Ensure that the encoder signal cables are placed in separate conduits from the cables connected to R, S, T and U, V, W terminals to prevent the interference. 3. Please use shielded cables for Encoder wiring. 4. If the error does not clear after all the above actions are done, please contact your distributor for assistance or contact with Delta.

AL030 : Motor protection error

Potential Cause	Checking Method	Corrective Actions
The setting value of parameter P1-57 is reached after a period of time set by parameter P1-58.	<ol style="list-style-type: none"> 1. Check if P1-57 is enabled. 2. Check if the setting values of P1-57 and P1-58 are both too small. 	<ol style="list-style-type: none"> 1. Set P1-57 to 0. 2. Correctly set P1-57 and P1-58. Please note that the over-low setting may results in malfunction, but over-high setting may let the motor protection function not operate.

AL031 : U,V,W wiring error

Potential Cause	Checking Method	Corrective Actions
The wiring connections of U, V, W (for servo motor output) and GND (for grounding) are in error.	Check if wiring connections of U, V, W are not correct.	Follow the wiring steps in the user manual to reconnect the wiring and ground the servo drive and motor properly.

AL040 : Full closed-loop excessive deviation

Potential Cause	Checking Method	Corrective Actions
The position control deviation value of full-closed loop exceeds the specified limit. Maximum deviation parameter setting is too small.	<ol style="list-style-type: none"> 1. Check if the setting value of P1-73 is too small. 2. Check if all connections are tight and well-connected to the mechanical equipment. 	<ol style="list-style-type: none"> 1. Increases the parameter setting value of P1-73. 2. Ensure all connections are tight and well-connected to the mechanical equipment.

AL099 : DSP firmware upgrade

Potential Cause	Checking Method	Corrective Actions
EE-PROM is not reset after the firmware version is upgraded.	Check if EE-PROM is reset after the firmware version is upgraded.	Set P2-08 to 30 first, and then 28 next, and restart the servo drive.

CANopen Communication Fault Messages

AL185 : CANbus error

Potential Cause	Checking Method	Corrective Actions
CANbus off or Error Rx/Tx Counter exceeds 128.	<ol style="list-style-type: none"> 1. Examine CANbus communication cable. 2. Check if the communication quality is good quality state. (It is recommended to use shielded cables and use common grounding.) 	NMT Maser send "Reset node" command to its slave or restart the servo drive.

AL111 : CANopen SDO receive buffer overrun

Potential Cause	Checking Method	Corrective Actions
SDO Rx buffer overrun is detected (receive two or more SDO packets in 1ms).	Check if the servo drive (Master) receives two or more SDO packets in 1ms.	NMT Maser send "Reset node" command to its slave or reset the fault by sending the control word (0x6040) through CAN communication (the value of CANopen object 0x6040 should be reset)

AL 112 : CANopen PDO receive buffer overrun

Potential Cause	Checking Method	Corrective Actions
PDO Rx buffer overrun is detected (receive two or more PDO packets in 1ms).	Check if the servo drive (Master) receives two or more PDO (same COB-ID) packets in 1ms.	NMT Maser send "Reset node" command to its slave or reset the fault by sending the control word (0x6040) through CAN communication (the value of CANopen object 0x6040 should be reset)

AL 121 : Index error occurs when accessing PDO object

Potential Cause	Checking Method	Corrective Actions
The specified Index in the message does not exist.	Check if the Entry index value in PDO mapping is changed when accessing PDO object.	NMT Maser send "Reset node" command to its slave or reset the fault by sending the control word (0x6040) through CAN communication (the value of CANopen object 0x6040 should be reset)

AL 122 : Sub-index error occurs when accessing PDO object

Potential Cause	Checking Method	Corrective Actions
The specified Sub-index in the message does not exist.	Check if the Entry Sub-index value in PDO mapping is changed when accessing PDO object.	NMT Maser send "Reset node" command to its slave or reset the fault by sending the control word (0x6040) through CAN communication (the value of CANopen object 0x6040 should be reset)

AL 123 : Data type (size) error occurs when accessing PDO object

Potential Cause	Checking Method	Corrective Actions
The data length in the message does not match the specified object.	Check if the Entry data length in PDO mapping is changed when accessing PDO object.	NMT Maser send "Reset node" command to its slave or reset the fault by sending the control word (0x6040) through CAN communication (the value of CANopen object 0x6040 should be reset)

AL 124 : Data range error occurs when accessing PDO object

Potential Cause	Checking Method	Corrective Actions
The data in the message has exceeded the data range of the specified object.	Check if the write-in data range in PDO mapping is not correct when accessing PDO object.	NMT Maser send "Reset node" command to its slave or reset the fault by sending the control word (0x6040) through CAN communication (the value of CANopen object 0x6040 should be reset)

AL 125 : Object is read-only and write-protected

Potential Cause	Checking Method	Corrective Actions
The specified object in the message is read-only and write-protected (cannot be changed).	Check if the specified object is set to read-only write-protected (cannot be changed) when accessing PDO object.	NMT Maser send "Reset node" command to its slave or reset the fault by sending the control word (0x6040) through CAN communication (the value of CANopen object 0x6040 should be reset)

AL 126 : CANopen PDO object does not support PDO

Potential Cause	Checking Method	Corrective Actions
The specified object in the message cannot support PDO.	Check if the specified object cannot support PDO when accessing PDO object.	NMT Maser send "Reset node" command to its slave or reset the fault by sending the control word (0x6040) through CAN communication (the value of CANopen object 0x6040 should be reset)

AL 127 : CANopen PDO object is write-protected when Servo On

Potential Cause	Checking Method	Corrective Actions
The specified object in the message is write-protected (cannot be changed) when Servo On.	Check if the specified object in the message is write-protected (cannot be changed) while the servo drive is enabled (Servo On) when accessing PDO object.	NMT Maser send "Reset node" command to its slave or reset the fault by sending the control word (0x6040) through CAN communication (the value of CANopen object 0x6040 should be reset)

AL 128 : Error occurs when reading CANopen PDO object from EE-PROM

Potential Cause	Checking Method	Corrective Actions
An error occurs when loading the default settings from EE-PROM at start-up. All CANopen objects return to their default settings automatically.	Check if it causes an error when the specified object reads EE-PROM when accessing PDO object.	NMT Maser send "Reset node" command to its slave or reset the fault by sending the control word (0x6040) through CAN communication (the value of CANopen object 0x6040 should be reset)

AL 129 : Error occurs when writing CANopen PDO object into EE-PROM

Potential Cause	Checking Method	Corrective Actions
An error occurs when writing the current settings into EE-PROM.	Check if it causes an error when the specified object writes EE-PROM when accessing PDO object.	NMT Maser send "Reset node" command to its slave or reset the fault by sending the control word (0x6040) through CAN communication (the value of CANopen object 0x6040 should be reset)

AL 130 : EE-PROM invalid address range

Potential Cause	Checking Method	Corrective Actions
The amount of the data saved in EE-PROM has exceeded the space determined by the firmware. Maybe the firmware version has been upgraded, and it causes that the data of old firmware version saved in EE-PROM cannot be used.	Check if the specified object lets the address range of EE-PROM exceed the specification when accessing PDO object.	NMT Maser send "Reset node" command to its slave or reset the fault by sending the control word (0x6040) through CAN communication (the value of CANopen object 0x6040 should be reset)

AL 131 : EE-PROM checksum error

Potential Cause	Checking Method	Corrective Actions
The data saved in EE-PROM has been damaged and all CANopen objects return to their default settings automatically.	Check if the specified object results in the checksum error of EE-PROM when accessing PDO object.	NMT Maser send "Reset node" command to its slave or reset the fault by sending the control word (0x6040) through CAN communication (the value of CANopen object 0x6040 should be reset)

AL 132 : Password error

Potential Cause	Checking Method	Corrective Actions
The parameter is password protected when using CANopen communication to access the parameter.	Check if the password for the specified object is invalid when accessing PDO object.	NMT Master send "Reset node" command to its slave or reset the fault by sending the control word (0x6040) through CAN communication (the value of CANopen object 0x6040 should be reset)

Motion Control Fault Messages

AL 201 : CANopen data initial error

Potential Cause	Checking Method	Corrective Actions
An error occurs when loading data from EE-PROM.	<ol style="list-style-type: none"> 1. Restart the servo drive to check if the error can be cleared. 2. If the error cannot be cleared after restarting the servo drive, it indicates that the data in EE-PROM is damaged and the users must do the following actions: <ol style="list-style-type: none"> a. If the users want to write default setting values, set P2-08 to 30 first and then 28 next, or use CANopen "0x1011" object to restore parameters from non-volatile memory. b. If the users want to write current setting values, use CANopen "0x1010" object to save parameters in non-volatile memory. 	<ol style="list-style-type: none"> 1. Turn ARST (DI signal) ON to clear the fault. 2. Use CANopen "0x1011" object to restore default parameters.

AL 213 ~ AL 219 : Write parameter error

Potential Cause	Checking Method	Corrective Actions
In PR mode, error occurs when using PR command TYPE=8 (write specified parameter)	AL 213 : Check if the parameter setting value exceeds the limit of normal range.	<ol style="list-style-type: none"> 1. Turn ARST (DI signal) ON to clear the fault. 2. Set P0-01 to 0.
	AL 215 : Check if the parameter is read only.	
	AL 217 , AL 219 : Check if the parameter is write-protected when Servo On or the setting value is invalid.	Correct the PR command and parameter setting value.

AL235 : PR command overflow

Potential Cause	Checking Method	Corrective Actions
In PR mode, this fault occurs when position command counter register overflowed and at this time an absolute position command is executed.	<ol style="list-style-type: none"> 1. In PR mode, check if the position command is executing continuously toward single direction and make the feedback position command counter overflow. 2. Check if the above situation causes that the correct position cannot be gauged. 3. Check if an absolute position command is executed after the position command counter register overflowed. 	NMT Maser send "Reset node" command to its slave or reset the fault by sending the control word (0x6040) through CAN communication (the value of CANopen object 0x6040 should be reset)

AL245 : PR positioning time out

Potential Cause	Checking Method	Corrective Actions
In PR mode, the execution time of positioning command exceeds its time limit.	If this fault occurs, please contact your distributor for assistance or contact with Delta.	NMT Maser send "Reset node" command to its slave or reset the fault by sending the control word (0x6040) through CAN communication (the value of CANopen object 0x6040 should be reset)

AL249 : Invalid PR path number

Potential Cause	Checking Method	Corrective Actions
In PR mode, the valid range of PR path number is within 0~63. The path number is not within this range.	If this fault occurs, please contact your distributor for assistance or contact with Delta.	NMT Maser send "Reset node" command to its slave or reset the fault by sending the control word (0x6040) through CAN communication (the value of CANopen object 0x6040 should be reset)

AL261 : Index error occurs when accessing CANopen object

Potential Cause	Checking Method	Corrective Actions
The specified Index in the message does not exist.	If this fault occurs, please contact your distributor for assistance or contact with Delta.	NMT Maser send "Reset node" command to its slave or reset the fault by sending the control word (0x6040) through CAN communication (the value of CANopen object 0x6040 should be reset)

AL263 : Sub-index error occurs when accessing CANopen object

Potential Cause	Checking Method	Corrective Actions
The specified Sub-index in the message does not exist.	If this fault occurs, please contact your distributor for assistance or contact with Delta.	NMT Maser send "Reset node" command to its slave or reset the fault by sending the control word (0x6040) through CAN communication (the value of CANopen object 0x6040 should be reset)

AL265 : Data type (size) error occurs when accessing CANopen object

Potential Cause	Checking Method	Corrective Actions
The data length in the message does not match the specified object.	If this fault occurs, please contact your distributor for assistance or contact with Delta.	NMT Maser send "Reset node" command to its slave or reset the fault by sending the control word (0x6040) through CAN communication (the value of CANopen object 0x6040 should be reset)

AL267 : Data range error occurs when accessing CANopen object

Potential Cause	Checking Method	Corrective Actions
The data in the message has exceeded the data range of the specified object.	If this fault occurs, please contact your distributor for assistance or contact with Delta.	NMT Maser send "Reset node" command to its slave or reset the fault by sending the control word (0x6040) through CAN communication (the value of CANopen object 0x6040 should be reset)

AL269 : Object is read-only and write-protected

Potential Cause	Checking Method	Corrective Actions
The specified object in the message is read-only and write-protected (cannot be changed).	If this fault occurs, please contact your distributor for assistance or contact with Delta.	NMT Maser send "Reset node" command to its slave or reset the fault by sending the control word (0x6040) through CAN communication (the value of CANopen object 0x6040 should be reset)

AL266 : CANopen object does not support PDO

Potential Cause	Checking Method	Corrective Actions
The specified object in the message does not support PDO.	If this fault occurs, please contact your distributor for assistance or contact with Delta.	NMT Maser send "Reset node" command to its slave or reset the fault by sending the control word (0x6040) through CAN communication (the value of CANopen object 0x6040 should be reset)

AL26d : Object is write-protected when Servo On

Potential Cause	Checking Method	Corrective Actions
The specified object in the message is write-protected (cannot be changed) when Servo On.	If this fault occurs, please contact your distributor for assistance or contact with Delta.	NMT Maser send "Reset node" command to its slave or reset the fault by sending the control word (0x6040) through CAN communication (the value of CANopen object 0x6040 should be reset)

AL26F : Error occurs when reading CANopen object from EE-PROM

Potential Cause	Checking Method	Corrective Actions
An error occurs when loading the default settings from EE-PROM at start-up. All CANopen objects return to their default settings automatically.	If this fault occurs, please contact your distributor for assistance or contact with Delta.	NMT Maser send "Reset node" command to its slave or reset the fault by sending the control word (0x6040) through CAN communication (the value of CANopen object 0x6040 should be reset)

AL271 : Error occurs when writing CANopen object into EE-PROM

Potential Cause	Checking Method	Corrective Actions
An error occurs when writing the current settings into EE-PROM.	If this fault occurs, please contact your distributor for assistance or contact with Delta.	NMT Maser send "Reset node" command to its slave or reset the fault by sending the control word (0x6040) through CAN communication (the value of CANopen object 0x6040 should be reset)

AL273 : EE-PROM invalid address range

Potential Cause	Checking Method	Corrective Actions
The amount of the data saved in EE-PROM has exceeded the space determined by the firmware. Maybe the firmware version has been upgraded, and it causes that the data of old firmware version saved in EE-PROM cannot be used.	If this fault occurs, please contact your distributor for assistance or contact with Delta.	NMT Maser send "Reset node" command to its slave or reset the fault by sending the control word (0x6040) through CAN communication (the value of CANopen object 0x6040 should be reset)

AL275 : EE-PROM checksum error

Potential Cause	Checking Method	Corrective Actions
The data saved in EE-PROM has been damaged and all CANopen objects return to their default settings automatically.	If this fault occurs, please contact your distributor for assistance or contact with Delta.	NMT Maser send "Reset node" command to its slave or reset the fault by sending the control word (0x6040) through CAN communication (the value of CANopen object 0x6040 should be reset)

AL277 : Password error

Potential Cause	Checking Method	Corrective Actions
The parameter is password protected when using CANopen communication to access the parameter.	If this fault occurs, please contact your distributor for assistance or contact with Delta.	NMT Maser send "Reset node" command to its slave or reset the fault by sending the control word (0x6040) through CAN communication (the value of CANopen object 0x6040 should be reset)

AL283 : Forward software limit

Potential Cause	Checking Method	Corrective Actions
Position command is equal to or more than forward software limit.	This software limit is determined according to position command, not actual feedback position. It indicates that when this fault is activated, the actual position may not exceed the limit. Setting the proper deceleration time is able to solve this problem. Please refer to parameter P5-03.	NMT Maser send "Reset node" command to its slave or reset the fault by sending the control word (0x6040) through CAN communication (the value of CANopen object 0x6040 should be reset)

AL 285 : Reverse software limit

Potential Cause	Checking Method	Corrective Actions
Position command is equal to or less than forward software limit.	This software limit is determined according to position command, not actual feedback position. It indicates that when this fault is activated, the actual position may not exceed the limit. Setting the proper deceleration time is able to solve this problem. Please refer to parameter P5-03.	NMT Maser send "Reset node" command to its slave or reset the fault by sending the control word (0x6040) through CAN communication (the value of CANopen object 0x6040 should be reset)

AL 289 : Position counter overflow

Potential Cause	Checking Method	Corrective Actions
Position counter overflow occurs.	If this fault occurs, please contact your distributor for assistance or contact with Delta.	NMT Maser send "Reset node" command to its slave or reset the fault by sending the control word (0x6040) through CAN communication (the value of CANopen object 0x6040 should be reset)

AL 291 : Servo Off error

Potential Cause	Checking Method	Corrective Actions
Servo Off occurs during positioning (when the drive and motor are both running).	<ol style="list-style-type: none"> 1.Examine if the wiring of digital input for Servo On is correct. 2.Check if the host (external) controller disables the function of Servo On too early. 	NMT Maser send "Reset node" command to its slave or reset the fault by sending the control word (0x6040) through CAN communication (the value of CANopen object 0x6040 should be reset)

AL 301 : CANopen SYNC failed

Potential Cause	Checking Method	Corrective Actions
CAN IP mode error. The synchronous communication with the external controller has failed.	<ol style="list-style-type: none"> 1.Check if the communication quality is good quality state. 2.Check if the host (external) controller has sent SYNC signal. 3.Check if the setting value of parameter P3-09 is a proper value (It is recommended to use default setting). 	NMT Maser send "Reset node" command to its slave or reset the fault by sending the control word (0x6040) through CAN communication (the value of CANopen object 0x6040 should be reset)

AL 302 : CANopen SYNC error

Potential Cause	Checking Method	Corrective Actions
CAN IP mode error. The SYNC signal is received too early.	<ol style="list-style-type: none"> 1. Check if the setting of 0x1006 (communication cycle period) is the same as the setting in host (external) controller. 2. Check if the setting value of parameter P3-09 is a proper value (It is recommended to use default setting). 3. Check if the procedure of host (external) controller is not correct. 	NMT Maser send "Reset node" command to its slave or reset the fault by sending the control word (0x6040) through CAN communication (the value of CANopen object 0x6040 should be reset)

AL 303 : CANopen SYNC time out

Potential Cause	Checking Method	Corrective Actions
CAN IP mode error. The SYNC signal is not received with the specified time.	<ol style="list-style-type: none"> 1. Check if the communication quality is good quality state. 2. Check if the setting of 0x1006 (communication cycle period) is the same as the setting in host (external) controller. 3. Check if the setting value of parameter P3-09 is a proper value (It is recommended to use default setting). 4. Check if the procedure of host (external) controller is not correct. 	NMT Maser send "Reset node" command to its slave or reset the fault by sending the control word (0x6040) through CAN communication (the value of CANopen object 0x6040 should be reset)

AL 304 : CANopen IP command failed

Potential Cause	Checking Method	Corrective Actions
CAN IP mode error. Internal command cannot be sent and received.	The calculation time of IP mode is too long. Please disable USB monitor function.	NMT Maser send "Reset node" command to its slave or reset the fault by sending the control word (0x6040) through CAN communication (the value of CANopen object 0x6040 should be reset)

AL 305 : SYNC period error

Potential Cause	Checking Method	Corrective Actions
Object 0x1006 Data Error. SYNC period 1006h value is invalid.	Examine the data of 0x1006. The SYNC period 1006h value should not be equal to or less than 0 or this fault will occur.	NMT Maser send "Reset node" command to its slave or reset the fault by sending the control word (0x6040) through CAN communication (the value of CANopen object 0x6040 should be reset)

AL 380 : Position deviation alarm for digital output, MC_OK

Potential Cause	Checking Method	Corrective Actions
After MC_OK is activated, when the digital output, TPOS is Off, the digital output, MC_OK becomes Off.	Check if the motor position changes by external force after the positioning is completed. This alarm can be disabled by the setting of P1-48. Please refer to the descriptions of parameter P1-48 for more detailed explanation.	<ol style="list-style-type: none"> 1. Turn ARST (DI signal) ON to clear the fault. 2. Set P0-01 to 0.

10.3 Clearing Faults

Servo Drive Fault Messages

Display	Fault Name	Clearing Method
AL001	Overcurrent	Turn ARST (DI signal) ON to clear the fault.
AL002	Overvoltage	Turn ARST (DI signal) ON to clear the fault.
AL003	Undervoltage	This fault message can be removed automatically after the voltage has returned within its specification.
AL004	Motor error	This fault message can be removed by restarting the servo drive.
AL005	Regeneration error	Turn ARST (DI signal) ON to clear the fault.
AL006	Overload	Turn ARST (DI signal) ON to clear the fault.
AL007	Overspeed	Turn ARST (DI signal) ON to clear the fault.
AL008	Abnormal pulse control command	Turn ARST (DI signal) ON to clear the fault.
AL009	Excessive deviation	Turn ARST (DI signal) ON to clear the fault.
AL010	Reserved	
AL011	Encoder error	This fault message can be removed by restarting the servo drive.
AL012	Adjustment error	This fault message can be removed after the wiring of CN1 connector (I/O signal connector) is removed and auto adjustment function is executed.
AL013	Emergency stop activated	This fault message can be removed automatically by turning off EMGS (DI signal).
AL014	Reverse limit switch error	<ol style="list-style-type: none"> 1. Turn ARST (DI signal) ON to clear the fault. 2. This fault message can be removed when the servo drive is Off (Servo Off). 3. When the servo drive does not reach the limit, this fault message can be removed automatically
AL015	Forward limit switch error	<ol style="list-style-type: none"> 1. Turn ARST (DI signal) ON to clear the fault. 2. This fault message can be removed when the servo drive is Off (Servo Off). 3. When the servo drive does not reach the limit, this fault message can be removed automatically
AL016	IGBT temperature error	Turn ARST (DI signal) ON to clear the fault.

Display	Fault Name	Clearing Method
AL017	Memory error	<ol style="list-style-type: none"> 1. If this fault occurs when power is applied to the drive, correct the setting value of the parameter to clear the fault and restart the servo drive. 2. If this fault occurs during normal operation, turn ARST (DI signal) ON to clear the fault.
AL018	Encoder output error	Turn ARST (DI signal) ON to clear the fault.
AL019	Serial communication error	Turn ARST (DI signal) ON to clear the fault.
AL020	Serial communication time out	Turn ARST (DI signal) ON to clear the fault.
AL021	Reserved	
AL022	Input power phase loss	Turn ARST (DI signal) ON to clear the fault. This fault message can be removed automatically after input power phase lost problem is solved.
AL023	Pre-overload warning	Turn ARST (DI signal) ON to clear the fault.
AL024	Encoder initial magnetic field error	This fault message can be removed by restarting the servo drive.
AL025	Encoder internal error	This fault message can be removed by restarting the servo drive.
AL026	Encoder data error	This fault message can be removed by restarting the servo drive.
AL030	Motor protection error	Turn ARST (DI signal) ON to clear the fault.
AL031	U,V,W wiring error	This fault message can be removed by restarting the servo drive.
AL040	Ful closed-loop excessive deviation	Turn ARST (DI signal) ON to clear the fault.
AL099	DSP firmware upgrade	This fault message can be removed after setting P2-08 to 30 first, and then 28 next and restarting the servo drive.

CANopen Communication Fault Messages

Display	Fault Name	Clearing Method
AL 185	CANbus error	NMT Maser send "Reset node" command to its slave or restart the servo drive.
AL 111	CANopen SDO receive buffer overrun	NMT Maser send "Reset node" command to its slave or reset the fault by sending the control word (0x6040) through CAN communication (the value of CANopen object 0x6040 should be reset).
AL 112	CANopen PDO receive buffer overrun	NMT Maser send "Reset node" command to its slave or reset the fault by sending the control word (0x6040) through CAN communication (the value of CANopen object 0x6040 should be reset).
AL 121	Index error occurs when accessing CANopen PDO object.	NMT Maser send "Reset node" command to its slave or reset the fault by sending the control word (0x6040) through CAN communication (the value of CANopen object 0x6040 should be reset).
AL 122	Sub-index error occurs when accessing CANopen PDO object.	NMT Maser send "Reset node" command to its slave or reset the fault by sending the control word (0x6040) through CAN communication (the value of CANopen object 0x6040 should be reset).
AL 123	Data type (size) error occurs when accessing CANopen PDO object.	NMT Maser send "Reset node" command to its slave or reset the fault by sending the control word (0x6040) through CAN communication (the value of CANopen object 0x6040 should be reset).
AL 124	Data range error occurs when accessing CANopen PDO object.	NMT Maser send "Reset node" command to its slave or reset the fault by sending the control word (0x6040) through CAN communication (the value of CANopen object 0x6040 should be reset).
AL 125	CANopen PDO object is read-only and write-protected.	NMT Maser send "Reset node" command to its slave or reset the fault by sending the control word (0x6040) through CAN communication (the value of CANopen object 0x6040 should be reset).
AL 126	CANopen PDO object does not support PDO.	NMT Maser send "Reset node" command to its slave or reset the fault by sending the control word (0x6040) through CAN communication (the value of CANopen object 0x6040 should be reset).
AL 127	CANopen PDO object is write-protected when Servo On.	NMT Maser send "Reset node" command to its slave or reset the fault by sending the control word (0x6040) through CAN communication (the value of CANopen object 0x6040 should be reset).

Display	Fault Name	Clearing Method
AL 128	Error occurs when reading CANopen PDO object from EE-PROM.	NMT Maser send "Reset node" command to its slave or reset the fault by sending the control word (0x6040) through CAN communication (the value of CANopen object 0x6040 should be reset).
AL 129	Error occurs when writing CANopen PDO object into EE-PROM.	NMT Maser send "Reset node" command to its slave or reset the fault by sending the control word (0x6040) through CAN communication (the value of CANopen object 0x6040 should be reset).
AL 130	EE-PROM invalid address range.	NMT Maser send "Reset node" command to its slave or reset the fault by sending the control word (0x6040) through CAN communication (the value of CANopen object 0x6040 should be reset).
AL 131	EE-PROM checksum error.	NMT Maser send "Reset node" command to its slave or reset the fault by sending the control word (0x6040) through CAN communication (the value of CANopen object 0x6040 should be reset).
AL 132	Password error	NMT Maser send "Reset node" command to its slave or reset the fault by sending the control word (0x6040) through CAN communication (the value of CANopen object 0x6040 should be reset).

Motion Control Fault Messages

Display	Fault Name	Clearing Method
AL201	CANopen Data Initial Error	<ol style="list-style-type: none"> 1. Turn ARST (DI signal) ON to clear the fault. 2. Use CANopen "0x1011" object to restore default parameters.
AL213	Write parameter error: exceeds the limit of normal range.	<ol style="list-style-type: none"> 1. Turn ARST (DI signal) ON to clear the fault. 2. Set P0-01 to 0.
AL215	Write parameter error: read only.	<ol style="list-style-type: none"> 1. Turn ARST (DI signal) ON to clear the fault. 2. Set P0-01 to 0.
AL217	Write parameter error: parameter lock	Correct the PR command and parameter setting value.
AL219	Write parameter error: parameter lock	Correct the PR command and parameter setting value.
AL235	PR Command Overflow	NMT Maser send "Reset node" command to its slave or reset the fault by sending the control word (0x6040) through CAN communication (the value of CANopen object 0x6040 should be reset).
AL245	PR Positioning Time out	NMT Maser send "Reset node" command to its slave or reset the fault by sending the control word (0x6040) through CAN communication (the value of CANopen object 0x6040 should be reset).
AL249	Invalid PR Path Number	NMT Maser send "Reset node" command to its slave or reset the fault by sending the control word (0x6040) through CAN communication (the value of CANopen object 0x6040 should be reset).
AL261	Index error occurs when accessing CANopen object.	NMT Maser send "Reset node" command to its slave or reset the fault by sending the control word (0x6040) through CAN communication (the value of CANopen object 0x6040 should be reset).
AL263	Sub-index error occurs when accessing CANopen object.	NMT Maser send "Reset node" command to its slave or reset the fault by sending the control word (0x6040) through CAN communication (the value of CANopen object 0x6040 should be reset).
AL265	Data type (size) error occurs when accessing CANopen object.	NMT Maser send "Reset node" command to its slave or reset the fault by sending the control word (0x6040) through CAN communication (the value of CANopen object 0x6040 should be reset).

Display	Fault Name	Clearing Method
AL267	Data range error occurs when accessing CANopen object.	NMT Maser send "Reset node" command to its slave or reset the fault by sending the control word (0x6040) through CAN communication (the value of CANopen object 0x6040 should be reset).
AL269	Object is read-only and write-protected.	NMT Maser send "Reset node" command to its slave or reset the fault by sending the control word (0x6040) through CAN communication (the value of CANopen object 0x6040 should be reset).
AL266	CANopen object does not support PDO.	NMT Maser send "Reset node" command to its slave or reset the fault by sending the control word (0x6040) through CAN communication (the value of CANopen object 0x6040 should be reset).
AL26d	CANopen object is write-protected when Servo On.	NMT Maser send "Reset node" command to its slave or reset the fault by sending the control word (0x6040) through CAN communication (the value of CANopen object 0x6040 should be reset).
AL26F	Error occurs when reading CANopen object from EE-PROM.	NMT Maser send "Reset node" command to its slave or reset the fault by sending the control word (0x6040) through CAN communication (the value of CANopen object 0x6040 should be reset).
AL271	Error occurs when writing CANopen object into EE-PROM.	NMT Maser send "Reset node" command to its slave or reset the fault by sending the control word (0x6040) through CAN communication (the value of CANopen object 0x6040 should be reset).
AL273	EE-PROM invalid address range	NMT Maser send "Reset node" command to its slave or reset the fault by sending the control word (0x6040) through CAN communication (the value of CANopen object 0x6040 should be reset).
AL275	EE-PROM checksum error	NMT Maser send "Reset node" command to its slave or reset the fault by sending the control word (0x6040) through CAN communication (the value of CANopen object 0x6040 should be reset).
AL277	Password error	NMT Maser send "Reset node" command to its slave or reset the fault by sending the control word (0x6040) through CAN communication (the value of CANopen object 0x6040 should be reset).
AL283	Forward software limit	When the servo drive does not reach the limit, i.e. the position command is less than forward software limit, this fault message can be removed automatically

Display	Fault Name	Clearing Method
AL285	Reverse software limit	When the servo drive does not reach the limit, i.e. the position command is more than reverse software limit, this fault message can be removed automatically
AL289	Position counter overflow	NMT Maser send "Reset node" command to its slave or reset the fault by sending the control word (0x6040) through CAN communication (the value of CANopen object 0x6040 should be reset).
AL291	Servo Off error	NMT Maser send "Reset node" command to its slave or reset the fault by sending the control word (0x6040) through CAN communication (the value of CANopen object 0x6040 should be reset).
AL301	CANopen SYNC failed	NMT Maser send "Reset node" command to its slave or reset the fault by sending the control word (0x6040) through CAN communication (the value of CANopen object 0x6040 should be reset).
AL302	CANopen SYNC signal error	NMT Maser send "Reset node" command to its slave or reset the fault by sending the control word (0x6040) through CAN communication (the value of CANopen object 0x6040 should be reset).
AL303	CANopen SYNC time out	NMT Maser send "Reset node" command to its slave or reset the fault by sending the control word (0x6040) through CAN communication (the value of CANopen object 0x6040 should be reset).
AL304	CANopen IP command failed	NMT Maser send "Reset node" command to its slave or reset the fault by sending the control word (0x6040) through CAN communication (the value of CANopen object 0x6040 should be reset).
AL305	SYNC period error	NMT Maser send "Reset node" command to its slave or reset the fault by sending the control word (0x6040) through CAN communication (the value of CANopen object 0x6040 should be reset).
AL380	Position deviation alarm	<ol style="list-style-type: none"> 1. Turn ARST (DI signal) ON to clear the fault. 2. Set P0-01 to 0.

This page intentionally left blank.


Chapter 11 Specifications

11.1 Specifications of Servo Drives (ASDA-A2 Series)

11.1.1 ASDA-A2 220V Series

ASDA-A2 Series		100W	200W	400W	750W	1kW	1.5kW	2kW	3kW	4.5kW	5.5kW	7.5kW	
		01	02	04	07	10	15	20	30	45	55	75	
Power supply	Phase / Voltage	Three-phase / Single-phase 220VAC						Three-phase 220VAC					
	Permissible Voltage Range	Three-phase / Single-phase 200 ~ 230VAC, -15% ~ 10%						Three-phase 200 ~ 230VAC, -15% ~ 10%					
	Continuous Output Current	0.9 Arms	1.55 Arms	2.6 Arms	5.1 Arms	7.3 Arms	8.3 Arms	13.4 Arms	19.4 Arms	32.5 Arms	40 Arms	47.5 Arms	
Cooling System		Natural Air Circulation			Fan Cooling								
Encoder Resolution / Feedback Resolution		20-bit (1280000 p/rev)											
Control of Main Circuit		SVPWM (Space Vector Pulse Width Modulation) Control											
Tuning Modes		Auto / Manual											
Dynamic Brake		None			Built-in						External		
Position Control Mode	Max. Input Pulse Frequency	Max. 500Kpps / 4Mpps (Line driver), Max. 200Kpps (Open collector)											
	Pulse Type	Pulse + Direction, A phase + B phase, CCW pulse + CW pulse											
	Command Source	External pulse train (PT mode) / Internal parameters (PR mode)											
	Smoothing Strategy	Low-pass and P-curve filter											
	Electronic Gear	Electronic gear N/M multiple N: 1~32767, M: 1:32767 (1/50<N/M<25600)											
	Torque Limit Operation	Set by parameters											
	Feed Forward Compensation	Set by parameters											
Speed Control Mode	Analog Input Command	Voltage Range		0 ~ ±10 V _{DC}									
		Input Resistance		10KΩ									
		Time Constant		2.2 us									
	Speed Control Range ¹⁾		1:5000									1:3000	
	Command Source		External analog signal / Internal parameters										
	Smoothing Strategy		Low-pass and S-curve filter										
	Torque Limit Operation		Set by parameters or via analog input										
	Frequency Response Characteristic		Maximum 1kHz										
Speed Accuracy ²⁾ (at rated rotation speed)		0.01% or less at 0 to 100% load fluctuation											
		0.01% or less at ±10% power fluctuation											
		0.01% or less at 0°C to 50°C ambient temperature fluctuation											

ASDA-A2**Chapter 11 Specifications**

ASDA-A2 Series			100W	200W	400W	750W	1kW	1.5kW	2kW	3kW	4.5kW	5.5kW	7.5kW
			01	02	04	07	10	15	20	30	45	55	75
Torque Control Mode	Analog Input Command	Voltage Range	0 ~ ±10 V _{dc}										
		Input Resistance	10KΩ										
		Time Constant	2.2 us										
	Command Source		External analog signal / Internal parameters										
	Smoothing Strategy		Low-pass filter										
	Speed Limit Operation		Set by parameters or via analog input										
Analog Monitor Output			Monitor signal can set by parameters (Output voltage range: ±8V)										
Digital Inputs/Outputs	Inputs		Servo on, Reset, Gain switching, Pulse clear, Zero speed CLAMP, Command input reverse control, Command triggered, Speed/Torque limit enabled, Position command selection, Motor stop, Speed position selection, Position / Speed mode switching, Speed / Torque mode switching, Torque / Position mode switching, PT / PR command switching, Emergency stop, Forward / Reverse inhibit limit, Reference "Home" sensor, Forward / Reverse operation torque limit, Move to "Home", Electronic Cam (E-Cam), Forward / Reverse JOG input, Event trigger PR command, Electronic gear ratio (Numerator) selection and Pulse inhibit input										
	Encoder signal output (A, B, Z Line Driver and Z Open Collector)												
	Outputs		Servo ready, Servo on, At Zero speed, At Speed reached, At Positioning completed, At Torques limit, Servo alarm (Servo fault) activated, Electromagnetic brake control, Homing completed, Output overload warning, Servo warning activated, Position command overflow, Forward / Reverse software limit, Internal position command completed, Capture operation completed output., Motion control completed output., Master position of E-Cam (Electronic Cam)										
Protective Functions			Overcurrent, Overvoltage, Undervoltage, Motor overheated, Regeneration error, Overload, Overspeed, Abnormal pulse control command, Excessive deviation, Encoder error, Adjustment error, Emergency stop activated, Reverse/ Forward limit switch error, Position excessive deviation of full-close control loop, Serial communication error, Input power phase loss, Serial communication time out, short circuit protection of U, V, W, and CN1, CN2, CN3 terminals										
Communication Interface			RS-232 / RS-485 / CANopen / USB										
Environment	Installation Site		Indoor location (free from direct sunlight), no corrosive liquid and gas (far away from oil mist, flammable gas, dust)										
	Altitude		Altitude 1000m or lower above sea level										
	Atmospheric pressure		86kPa to 106kPa										
	Operating Temperature		0°C ~ 55°C (If operating temperature is above 45°C, forced cooling will be required)										
	Storage Temperature		-20°C to 65°C (-4°F to 149°F)										
	Humidity		0 to 90% (non-condensing)										
	Vibration		9.80665m/s ² (1G) less than 20Hz, 5.88m/s ² (0.6G) 20 to 50Hz										
	IP Rating		IP20										
	Power System		TN System ³										
	Approvals		IEC/EN 61800-5-1, UL 508C, C-tick 										

Footnote:

- *1 Rated rotation speed: When full load, speed ratio is defined as the minimum speed (the motor will not pause).
- *2 When command is rated rotation speed, the speed fluctuation rate is defined as:
(Empty load rotation speed - Full load rotation speed) / Rated rotation speed
- *3 TN system: A power distribution system having one point directly earthed, the exposed conductive parts of the installation being connected to that points by protective earth conductor.
- *4 Please refer to "Chart of load and operating time" in section 11.4 "Overload Characteristics".
- *5 Please refer to Section 1.2 for details about the model explanation.

11.1.2 ASDA-A2 400V Series

ASDA-A2 Series		750W	1kW	1.5kW	2kW	3kW	4.5kW	5.5kW	7.5kW
		07	10	15	20	30	45	55	75
Power supply	Control Power		24VDC, $\pm 10\%$						
	Main Circuit Power		Three-phase, 380 ~ 480VAC, $\pm 10\%$						
	Continuous Output Current		3.07 Arms	3.52 Arms	5.02 Arms	6.66 Arms	11.9 Arms	20 Arms	22.37 Arms
Cooling System		Fan Cooling							
Encoder Resolution / Feedback Resolution		20-bit (1280000 p/rev)							
Control of Main Circuit		SVPWM (Space Vector Pulse Width Modulation) Control							
Tuning Modes		Auto / Manual							
Dynamic Brake		Built-in						External	
Position Control Mode	Max. Input Pulse Frequency		Max. 500Kpps / 4Mpps (Line driver), Max. 200Kpps (Open collector)						
	Pulse Type		Pulse + Direction, A phase + B phase, CCW pulse + CW pulse						
	Command Source		External pulse train (PT mode) / Internal parameters (PR mode)						
	Smoothing Strategy		Low-pass and P-curve filter						
	Electronic Gear		Electronic gear N/M multiple N: 1~32767, M: 1:32767 (1/50<N/M<25600)						
	Torque Limit Operation		Set by parameters						
	Feed Forward Compensation		Set by parameters						
Speed Control Mode	Analog Input Command	Voltage Range		0 ~ $\pm 10 V_{DC}$					
		Input Resistance		10K Ω					
		Time Constant		2.2 us					
	Speed Control Range ^{*1}		1:5000					1:3000	
	Command Source		External analog signal / Internal parameters						
	Smoothing Strategy		Low-pass and S-curve filter						
	Torque Limit Operation		Set by parameters or via analog input						
	Frequency Response Characteristic		Maximum 1kHz						
	Speed Accuracy ^{*2} (at rated rotation speed)		0.01% or less at 0 to 100% load fluctuation						
			0.01% or less at $\pm 10\%$ power fluctuation						
0.01% or less at 0°C to 50°C ambient temperature fluctuation									
Torque Control Mode	Analog Input Command	Voltage Range		0 ~ $\pm 10 V_{DC}$					
		Input Resistance		10K Ω					
		Time Constant		2.2 us					
	Command Source		External analog signal / Internal parameters						
	Smoothing Strategy		Low-pass filter						
	Speed Limit Operation		Set by parameters or via analog input						
Analog Monitor Output		Monitor signal can set by parameters (Output voltage range: $\pm 8V$)							

ASDA-A2 Series		750W	1kW	1.5kW	2kW	3kW	4.5kW	5.5kW	7.5kW
		07	10	15	20	30	45	55	75
Digital Inputs/Outputs	Inputs	Servo on, Reset, Gain switching, Pulse clear, Zero speed CLAMP, Command input reverse control, Command triggered, Speed/Torque limit enabled, Position command selection, Motor stop, Speed position selection, Position / Speed mode switching, Speed / Torque mode switching, Torque / Position mode switching, PT / PR command switching, Emergency stop, Forward / Reverse inhibit limit, Reference "Home" sensor, Forward / Reverse operation torque limit, Move to "Home", Electronic cam, Forward / Reverse JOG input, Event trigger PR command, Electronic gear ratio (Numerator) selection and Pulse inhibit input							
	Outputs	Encoder signal output (A, B, Z Line Driver and Z Open Collector) Servo ready, Servo on, At Zero speed, At Speed reached, At Positioning completed, At Torques limit, Servo alarm (Servo fault) activated, Electromagnetic brake control, Homing completed, Output overload warning, Servo warning activated, Position command overflow, Forward / Reverse software limit, Internal position command completed, Capture operation completed output., Motion control completed output., Master position of E-Cam (Electronic Cam)							
Protective Functions		Overcurrent, Overvoltage, Undervoltage, Motor overheated, Regeneration error, Overload, Overspeed, Abnormal pulse control command, Excessive deviation, Encoder error, Adjustment error, Emergency stop activated, Reverse/ Forward limit switch error, Position excessive deviation of full-close control loop, Serial communication error, Input power phase loss, Serial communication time out, short circuit protection of U, V, W, and CN1, CN2, CN3 terminals							
Communication Interface		RS-232 / RS-485 / CANopen / USB							
Environment	Installation Site	Indoor location (free from direct sunlight), no corrosive liquid and gas (far away from oil mist, flammable gas, dust)							
	Altitude	Altitude 1000m or lower above sea level							
	Atmospheric pressure	86kPa to 106kPa							
	Operating Temperature	0°C ~ 55°C (If operating temperature is above 45°C, forced cooling will be required)							
	Storage Temperature	-20°C to 65°C (-4°F to 149°F)							
	Humidity	0 to 90% (non-condensing)							
	Vibration	9.80665m/s ² (1G) less than 20Hz, 5.88m/s ² (0.6G) 20 to 50Hz							
	IP Rating	IP20							
	Power System	TN System ^{*3}							
Approvals	IEC/EN 61800-5-1, UL 508C, C-tick 								


Footnote:

- *1 Rated rotation speed: When full load, speed ratio is defined as the minimum speed (the motor will not pause).
- *2 When command is rated rotation speed, the speed fluctuation rate is defined as:
(Empty load rotation speed – Full load rotation speed) / Rated rotation speed
- *3 TN system: A power distribution system having one point directly earthed, the exposed conductive parts of the installation being connected to that points by protective earth conductor.
- *4 Please refer to "Chart of load and operating time" in section 11.4 "Overload Characteristics".
- *5 Please refer to Section 1.2 for details about the model explanation.

11.2 Specifications of Servo Motors (ECMA Series)**11.2.1 ECMA 220V Series****Low Inertia Series - 220V series**

ECMA Series	C104	C106		C108		C110	
	01	02	04	04	07	10	20
Rated output power (kW)	0.1	0.2	0.4	0.4	0.75	1.0	2.0
Rated torque (N·m) ⁻¹	0.32	0.64	1.27	1.27	2.39	3.18	6.37
Maximum torque (N·m)	0.96	1.92	3.82	3.82	7.16	9.54	19.1
Rated speed (r/min)	3000						
Maximum speed (r/min)	5000						
Rated current (A)	0.90	1.55	2.60	2.60	5.10	7.30	12.05
Power rating (kW/s)	2.70	4.65	7.80	7.80	15.3	21.9	36.15
Rotor moment of inertia (Kg·m ²) (without brake)	27.7	22.4	57.6	24.0	50.4	38.1	90.6
Mechanical time constant (ms)	0.037	0.177	0.277	0.68	1.13	2.65	4.45
Mechanical time constant (ms)	0.75	0.80	0.53	0.74	0.63	0.74	0.61
Torque constant-KT (N·m/A)	0.36	0.41	0.49	0.49	0.47	0.44	0.53
Voltage constant-KE (mV/(r/min))	13.6	16.0	17.4	18.5	17.2	16.8	19.2
Armature resistance (Ohm)	9.30	2.79	1.55	0.93	0.42	0.20	0.13
Armature inductance (mH)	24.0	12.07	6.71	7.39	3.53	1.81	1.50
Armature inductance (mH)	2.58	4.30	4.30	7.96	8.37	9.30	11.4
Insulation class	Class A (UL), Class B (CE)						
Insulation resistance	>100MΩ, DC 500V						
Insulation strength	1500V AC, 60 seconds						
Weight (kg) (without brake)	0.5	1.2	1.6	2.1	3.0	4.3	6.2
Weight (kg) (with brake)	0.8	1.5	2.0	2.9	3.8	4.7	7.2
Max. radial shaft load (N)	78.4	196	196	245	245	490	490
Max. thrust shaft load (N)	39.2	68	68	98	98	98	98
Power rating (kW/s) (with brake)	25.6	21.3	53.8	22.1	48.4	30.4	82.0
Rotor moment of inertia (Kg·m ²) (with brake)	0.04	0.19	0.30	0.73	1.18	3.33	4.95
Mechanical time constant (ms) (with brake)	0.81	0.85	0.57	0.78	0.65	0.93	0.66
Brake holding torque [Nt·m (min)]	0.3	1.3	1.3	2.5	2.5	8.0	8.0

Chapter 11 Specifications**ASDA-A2**

ECMA Series	C104	C106		C108		C110	
	01	02	04	04	07	10	20
Brake power consumption (at 20°C) [W]	7.3	6.5	6.5	8.2	8.2	19.4	19.4
Brake release time [ms (Max)]	5	10	10	10	10	10	10
Brake pull-in time [ms (Max)]	25	70	70	70	70	70	70
Vibration grade (µm)	15						
Operating temperature	0°C to 40°C (32°F to 104°F)						
Storage temperature	-10°C to 80°C (-14°F to 176°F)						
Operating humidity	20% to 90% RH (non-condensing)						
Storage humidity	20% to 90% RH (non-condensing)						
Vibration capacity	2.5G						
IP Rating	IP65 (when waterproof connectors are used, or when an oil seal is used to be fitted to the rotating shaft (an oil seal model is used))						
Approvals							

Footnote:

- *1 Rate torque values are continuous permissible values at 0~40°C ambient temperature when attaching with the sizes of heatsinks listed below:
 ECMA-__04 / 06 / 08 : 250mm x 250mm x 6mm
 ECMA-__10 : 300mm x 300mm x 12mm
 ECMA-__13 : 400mm x 400mm x 20mm
 ECMA-__18 : 550mm x 550mm x 30mm
 Material type : Aluminum - F40, F60, F80, F100, F130, F180



NOTE

- 1) Please refer to Section 1.2 for details about the model explanation.

Medium / High Inertia Series - 220V series

ECMA Series	E113				E118		G113		
	05	10	15	20	20	30	03	06	09
Rated output power (kW)	0.5	1.0	1.5	2.0	2.0	3.0	0.3	0.6	0.9
Rated torque (N-m) ^{*1}	2.39	4.77	7.16	9.55	9.55	14.32	2.86	5.73	8.59
Maximum torque (N-m)	7.16	14.3	21.48	28.65	28.65	42.97	8.59	17.19	21.48
Rated speed (r/min)	2000						1000		
Maximum speed (r/min)	3000						2000		
Rated current (A)	2.9	5.6	8.3	11.01	11.22	16.1	2.5	4.8	7.5
Maximum current (A)	8.7	16.8	24.9	33.03	33.66	48.3	7.5	14.4	22.5
Power rating (kW/s)	7.0	27.1	45.9	62.5	26.3	37.3	10.0	39.0	66.0
Rotor moment of inertia (Kg.m ²) (without brake)	8.17	8.41	11.18	14.59	34.68	54.95	8.17	8.41	11.18
Mechanical time constant (ms)	1.91	1.51	1.10	0.96	1.62	1.06	1.84	1.40	1.06
Torque constant-KT (N-m/A)	0.83	0.85	0.87	0.87	0.85	0.89	1.15	1.19	1.15
Voltage constant-KE (mV/(r/min))	30.9	31.9	31.8	31.8	31.4	32.0	42.5	43.8	41.6
Armature resistance (Ohm)	0.57	0.47	0.26	0.174	0.119	0.052	1.06	0.82	0.43
Armature inductance (mH)	7.39	5.99	4.01	2.76	2.84	1.38	14.29	11.12	6.97
Electrical time constant (ms)	12.96	12.88	15.31	15.86	23.87	26.39	13.55	13.50	16.06
Insulation class	Class A (UL), Class B (CE)								
Insulation resistance	>100MΩ, DC 500V								
Insulation strength	1500V AC, 60 seconds								
Weight (kg) (without brake)	6.8	7.0	7.5	7.8	13.5	18.5	6.8	7.0	7.5
Weight (kg) (with brake)	8.2	8.4	8.9	9.2	17.5	22.5	8.2	8.4	8.9
Max. radial shaft load (N)	490	490	490	490	1176	1470	490	490	490
Max. thrust shaft load (N)	98	98	98	98	490	490	98	98	98
Power rating (kW/s) (with brake)	6.4	24.9	43.1	59.7	24.1	35.9	9.2	35.9	62.1
Rotor moment of inertia (Kg.m ²) (with brake)	8.94	9.14	11.90	15.88	37.86	57.06	8.94	9.14	11.9
Mechanical time constant (ms) (with brake)	2.07	1.64	1.19	1.05	1.77	1.10	2.0	1.51	1.13
Brake holding torque [Nt-m (min)]	10.0	10.0	10.0	10.0	25.0	25.0	10.0	10.0	10.0
Brake power consumption (at 20°C) [W]	19.0	19.0	19.0	19.0	20.4	20.4	19.0	19.0	19.0

Chapter 11 Specifications**ASDA-A2**

ECMA Series	E113				E118		G113		
	05	10	15	20	20	30	03	06	09
Brake release time [ms (Max)]	10	10	10	10	10	10	10	10	10
Brake pull-in time [ms (Max)]	70	70	70	70	70	70	70	70	70
Vibration grade (μm)	15								
Operating temperature	0°C to 40°C (32°F to 104°F)								
Storage temperature	-10°C to 80°C (-14°F to 176°F)								
Operating humidity	20% to 90% RH (non-condensing)								
Storage humidity	20% to 90% RH (non-condensing)								
Vibration capacity	2.5G								
IP Rating	IP65 (when waterproof connectors are used, or when an oil seal is used to be fitted to the rotating shaft (an oil seal model is used))								
Approvals									

Footnote:

- *1 Rate torque values are continuous permissible values at 0~40°C ambient temperature when attaching with the sizes of heatsinks listed below:

ECMA-__04 / 06 / 08 : 250mm x 250mm x 6mm

ECMA-__10 : 300mm x 300mm x 12mm

ECMA-__13 : 400mm x 400mm x 20mm

ECMA-__18 : 550mm x 550mm x 30mm

Material type : Aluminum - F40, F60, F80, F100, F130, F180


 **NOTE**

- 1) Please refer to Section 1.2 for details about the model explanation.

Medium / Medium-High Inertia Series - 220V series

ECMA Series	F118			
	30	45	55	75
Rated output power (kW)	3.0	4.5	5.5	7.5
Rated torque (N-m) ^{*1}	19.10	28.65	35.01	47.74
Maximum torque (N-m)	57.29	71.62	87.53	119.36
Rated speed (r/min)	1500			
Maximum speed (r/min)	3000			
Rated current (A)	19.4	32.5	40.0	47.5
Maximum current (A)	58.2	81.3	100.0	118.8
Power rating (kW/s)	66.4	105.5	122.9	159.7
Rotor moment of inertia (Kg.m ²) (without brake)	54.95	77.75	99.78	142.7
Mechanical time constant (ms)	1.28	0.92	0.96	0.63
Torque constant-KT (N-m/A)	0.98	0.88	0.88	1.01
Voltage constant-KE (mV/(r/min))	35.0	32.0	31.0	35.5
Armature resistance (Ohm)	0.077	0.032	0.025	0.015
Armature inductance (mH)	1.27	0.89	0.60	0.40
Electrical time constant (ms)	16.5	27.8	24.0	26.7
Insulation class	Class A (UL), Class B (CE)			
Insulation resistance	>100MΩ, DC 500V			
Insulation strength	1500V AC, 60 seconds			
Weight (kg) (without brake)	18.5	23.5	30.5	37.0
Weight (kg) (with brake)	22.5	29	36	53
Max. radial shaft load (N)	1470	1470	1764	1764
Max. thrust shaft load (N)	490	490	588	588
Power rating (kW/s) (with brake)	63.9	101.8	119.4	156.6
Rotor moment of inertia (Kg.m ²) (with brake)	57.06	80.65	102.70	145.55
Mechanical time constant (ms) (with brake)	1.33	0.96	0.99	0.64
Brake holding torque [Nt-m (min)]	25.0	25.0	25.0	25.0
Brake power consumption (at 20°C) [W]	20.4	20.4	20.4	20.4

Chapter 11 Specifications**ASDA-A2**

ECMA Series	F118			
	30	45	55	75
Brake release time [ms (Max)]	10	10	10	10
Brake pull-in time [ms (Max)]	70	70	70	70
Vibration grade (μm)	15			
Operating temperature	0°C to 40°C (32°F to 104°F)			
Storage temperature	-10°C to 80°C (-14°F to 176°F)			
Operating humidity	20% to 90% RH (non-condensing)			
Storage humidity	20% to 90% RH (non-condensing)			
Vibration capacity	2.5G			
IP Rating	IP65 (when waterproof connectors are used, or when an oil seal is used to be fitted to the rotating shaft (an oil seal model is used))			
Approvals				

Footnote:

- *1 Rate torque values are continuous permissible values at 0~40°C ambient temperature when attaching with the sizes of heatsinks listed below:

ECMA-__04 / 06 / 08 : 250mm x 250mm x 6mm

ECMA-__10 : 300mm x 300mm x 12mm

ECMA-__13 : 400mm x 400mm x 20mm

ECMA-__18 : 550mm x 550mm x 30mm

Material type : Aluminum – F40, F60, F80, F100, F130, F180


 **NOTE**

- 1) Please refer to Section 1.2 for details about the model explanation.

11.2.2 ECMA 400V Series**Low / Medium Inertia Series - 400V series**

ECMA Series	J108		K113	
	07	10	15	20
Rated output power (kW)	0.75	1.0	1.5	2.0
Rated torque (N-m) ^{*1}	2.39	4.77	7.16	9.55
Maximum torque (N-m)	7.16	14.32	21.48	28.65
Rated speed (r/min)	3000	2000		
Maximum speed (r/min)	5000	3000		
Rated current (A)	3.07	3.52	5.02	6.66
Maximum current (A)	9.5	10.56	15.06	19.98
Power rating (kW/s)	50.4	27.1	45.9	62.5
Rotor moment of inertia (Kg.m ²) (without brake)	1.13	8.41	11.18	14.59
Mechanical time constant (ms)	0.66	1.80	1.24	1.04
Torque constant-KT (N-m/A)	0.78	1.35	1.43	1.43
Voltage constant-KE (mV/(r/min))	28.24	53.2	55	55
Armature resistance (Ohm)	1.22	1.47	0.83	0.57
Armature inductance (mH)	10.68	17.79	11.67	8.29
Electrical time constant (ms)	8.75	12.04	14.04	14.39
Insulation class	-			
Insulation resistance	>100MΩ, DC 500V			
Insulation strength	1800V AC, 60 seconds			
Weight (kg) (without brake)	3.0	7.0	7.5	7.8
Weight (kg) (with brake)	3.8	8.4	8.9	9.2
Max. radial shaft load (N)	245	490	490	490
Max. thrust shaft load (N)	98	98	98	98
Power rating (kW/s) (with brake)	48.4	24.9	43.1	59.7
Rotor moment of inertia (Kg.m ²) (with brake)	1.18	9.14	11.90	15.88
Mechanical time constant (ms) (with brake)	0.65	1.96	1.32	1.13
Brake holding torque [Nt-m (min)]	2.5	10.0	10.0	10.0

Chapter 11 Specifications**ASDA-A2**

ECMA Series	J108	K113		
	07	10	15	20
Brake power consumption (at 20°C) [W]	8.5	19.0	19.0	19.0
Brake release time [ms (Max)]	10	10	10	10
Brake pull-in time [ms (Max)]	70	70	70	70
Vibration grade (μm)	15			
Operating temperature	0°C to 40°C (32°F to 104°F)			
Storage temperature	-10°C to 80°C (-14°F to 176°F)			
Operating humidity	20% to 90% RH (non-condensing)			
Storage humidity	20% to 90% RH (non-condensing)			
Vibration capacity	2.5G			
IP Rating	IP65 (when waterproof connectors are used, or when an oil seal is used to be fitted to the rotating shaft (an oil seal model is used))			
Approvals				

Footnote:

- *1 Rate torque values are continuous permissible values at 0~40°C ambient temperature when attaching with the sizes of heatsinks listed below:

ECMA-__08 : 250mm x 250mm x 6mm

ECMA-__13 : 400mm x 400mm x 20mm

ECMA-__18 : 550mm x 550mm x 30mm

Material type : Aluminum – F80, F130, F180

Medium-High Inertia Series - 400V series

ECMA Series	L118			
	30	45	55	75
Rated output power (kW)	3.0	4.5	5.5	7.5
Rated torque (N-m) ^{*1}	19.10	28.65	35.0	47.75
Maximum torque (N-m)	57.29	71.62	87.53	119.38
Rated speed (r/min)	1500			
Maximum speed (r/min)	3000			
Rated current (A)	11.9	20.0	22.37	28.39
Maximum current (A)	35.7	50	56	70.9
Power rating (kW/s)	66.4	105.5	122.9	159.7
Rotor moment of inertia (Kg.m ²) (without brake)	54.95	77.75	99.78	142.7
Mechanical time constant (ms)	1.11	0.92	0.88	156.6
Torque constant-KT (N-m/A)	1.66	1.43	1.50	1.68
Voltage constant-KE (mV/(r/min))	60.54	55.63	57.99	65.37
Armature resistance (Ohm)	0.19	0.09	0.07	0.05
Armature inductance (mH)	4.8	2.7	2.55	1.7
Electrical time constant (ms)	24.7	30	31.7	34.14
Insulation class	-			
Insulation resistance	>100MΩ, DC 500V			
Insulation strength	1800V AC, 60 seconds			
Weight (kg) (without brake)	18.5	23.5	30.5	40.5
Weight (kg) (with brake)	22.5	29	36	46
Max. radial shaft load (N)	1470	1470	1764	1764
Max. thrust shaft load (N)	490	490	588	588
Power rating (kW/s) (with brake)	63.9	101.8	119.1	156.6
Rotor moment of inertia (Kg.m ²) (with brake)	57.06	80.65	102.70	145.5
Mechanical time constant (ms) (with brake)	1.16	0.95	0.91	0.69
Brake holding torque [Nt-m (min)]	25.0	40.0	55.0	55.0
Brake power consumption (at 20°C) [W]	20.4	15.1	21	21

Chapter 11 Specifications**ASDA-A2**

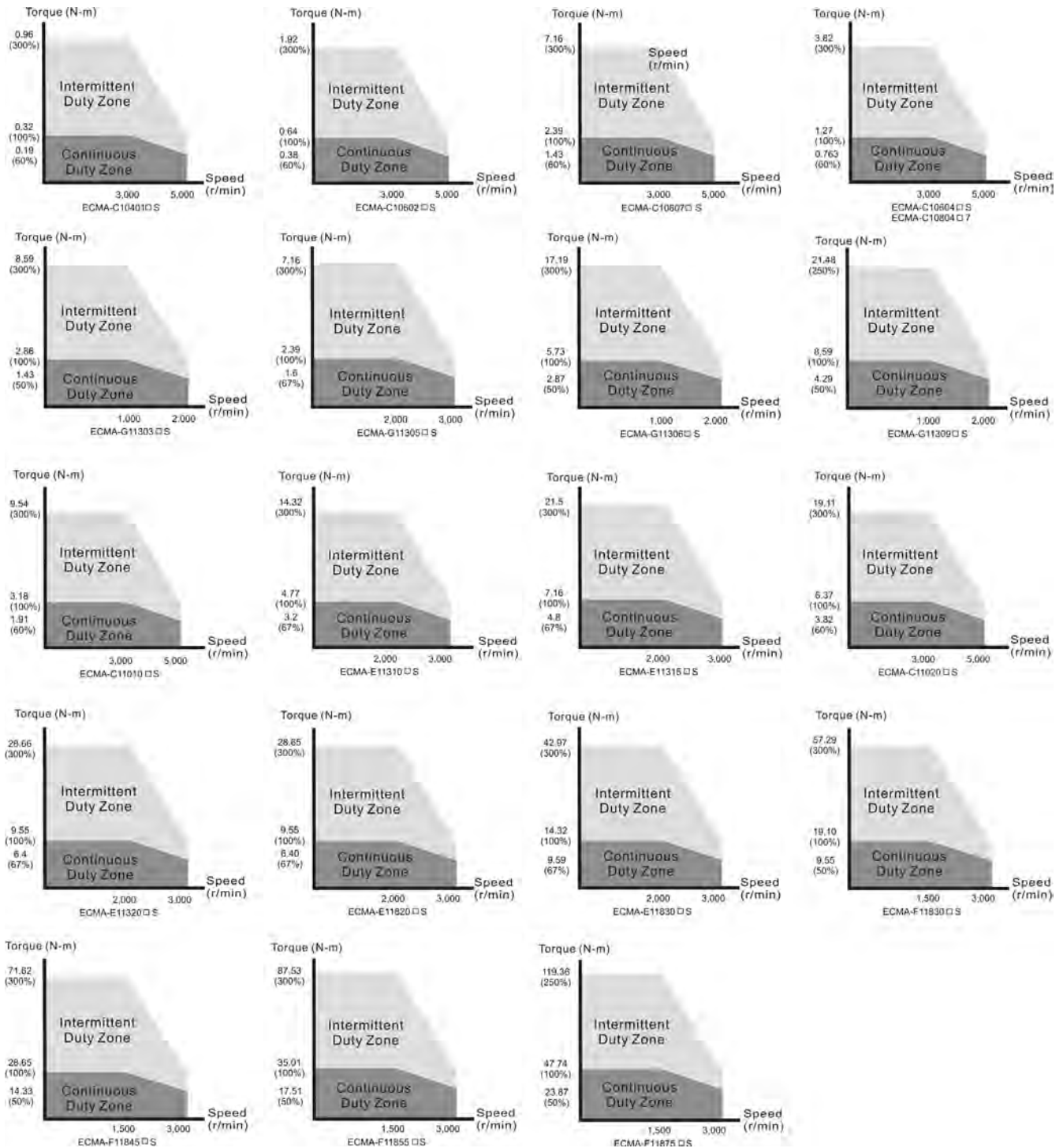
ECMA Series	L118			
	30	45	55	75
Brake release time [ms (Max)]	10	10	10	10
Brake pull-in time [ms (Max)]	70	70	70	70
Vibration grade (μm)	15			
Operating temperature	0°C to 40°C (32°F to 104°F)			
Storage temperature	-10°C to 80°C (-14°F to 176°F)			
Operating humidity	20% to 90% RH (non-condensing)			
Storage humidity	20% to 90% RH (non-condensing)			
Vibration capacity	2.5G			
IP Rating	IP65 (when waterproof connectors are used, or when an oil seal is used to be fitted to the rotating shaft (an oil seal model is used))			
Approvals	All models are in the process of application to CE and UL certifications.			

Footnote:

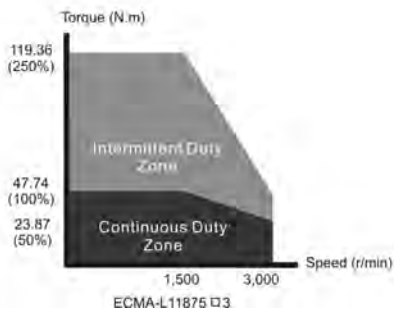
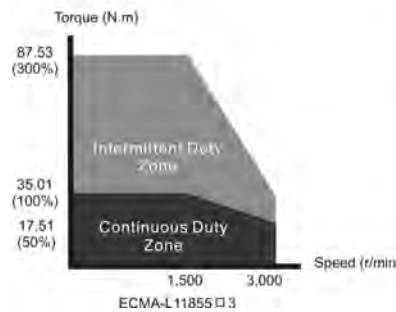
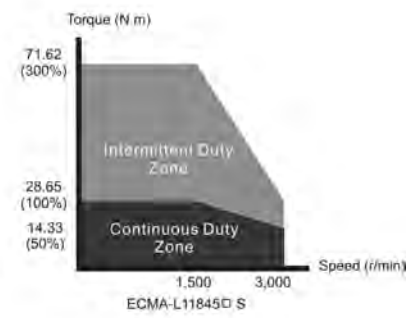
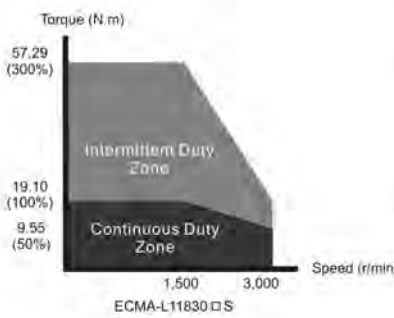
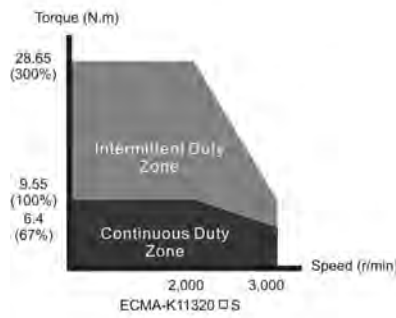
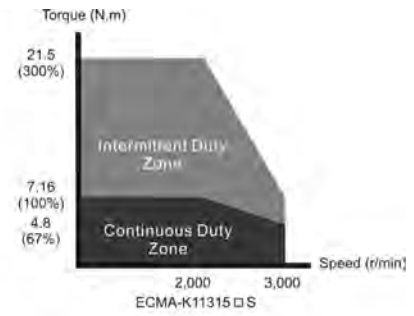
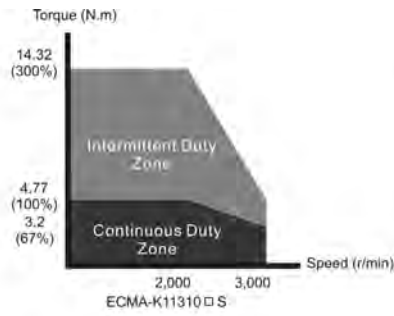
- *1 Rate torque values are continuous permissible values at 0~40°C ambient temperature when attaching with the sizes of heatsinks listed below:
 ECMA-__08 : 250mm x 250mm x 6mm
 ECMA-__13 : 400mm x 400mm x 20mm
 ECMA-__18 : 550mm x 550mm x 30mm
 Material type : Aluminum – F80, F130, F180

11.3 Servo Motor Speed-Torque Curves (T-N Curves)

11.3.1 220V Series



11.3.2 400V Series



11.4 Overload Characteristics

■ Overload Protection Function

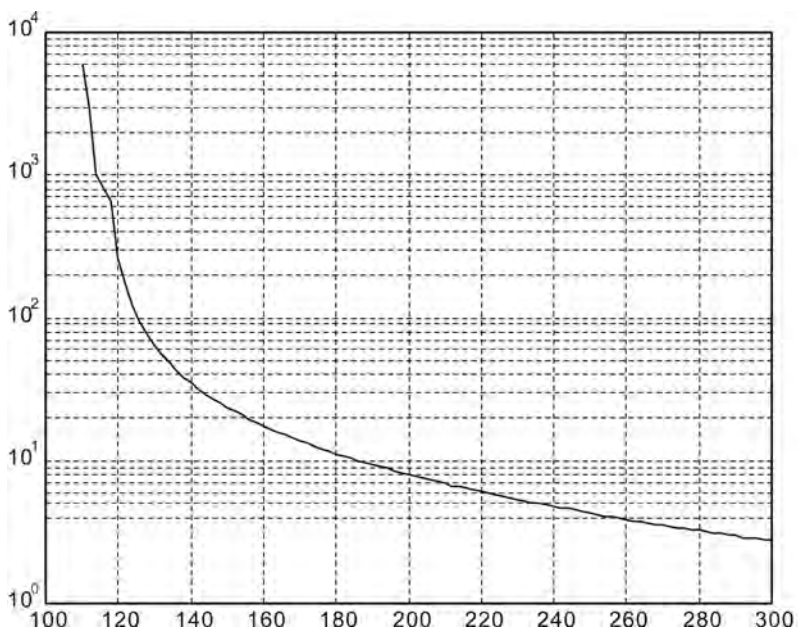
Overload protection is a built-in protective function to prevent a motor from overheating.

■ Occasion of Overload

1. Motor was operated for several seconds under a torque exceeding 100% torque.
2. Motor had driven high inertia machine and had accelerated and decelerated at high frequency.
3. Motor UVW cable or encoder cable was not connected correctly.
4. Servo gain was not set properly and caused motor hunting.
5. Motor holding brake was not released.

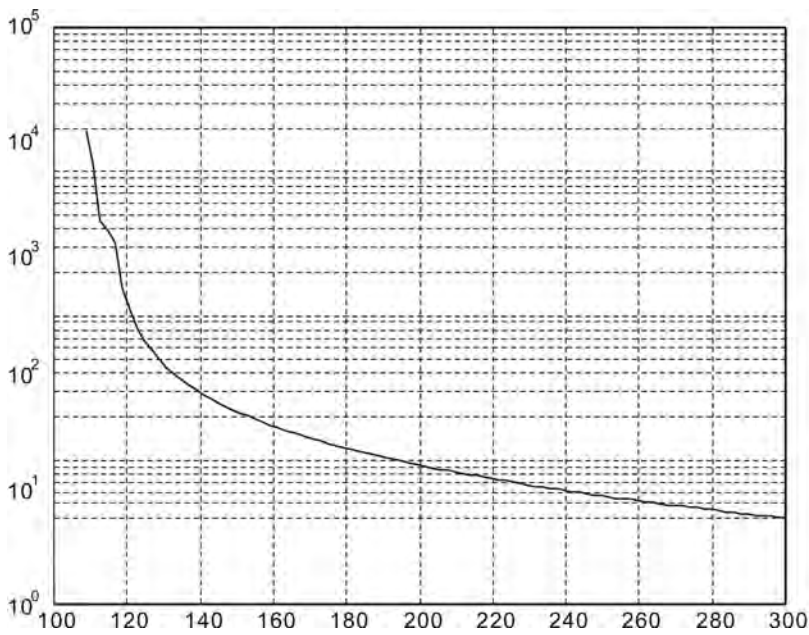
■ Chart of load and operating time

Low Inertia Series (ECMA C1, J1 Series)



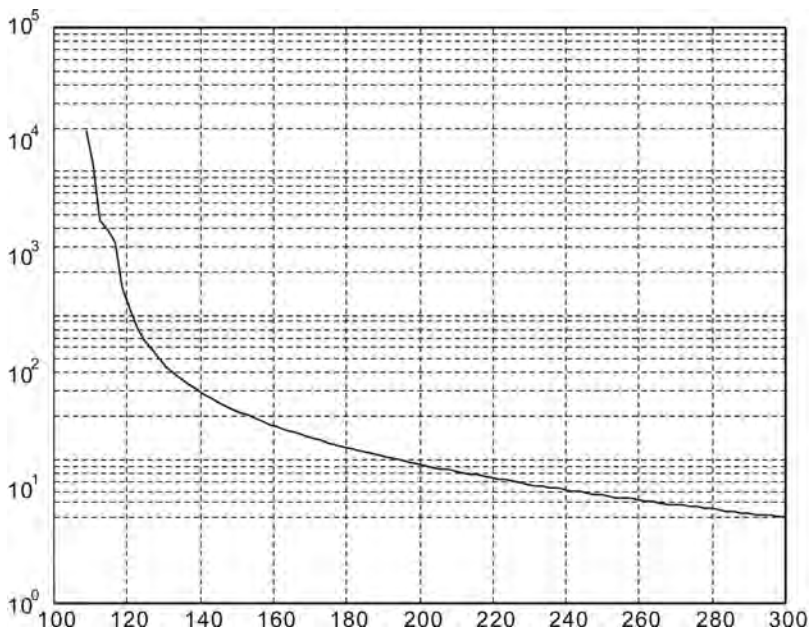
Load	Operating Time
120%	263.8s
140%	35.2s
160%	17.6s
180%	11.2s
200%	8s
220%	6.1s
240%	4.8s
260%	3.9s
280%	3.3s
300%	2.8s

Medium and Medium-High Inertia Series (ECMA E1, F1, K1 and L1 Series)



Load	Operating Time
120%	527.6s
140%	70.4s
160%	35.2s
180%	22.4s
200%	16s
220%	12.2s
240%	9.6s
260%	7.8s
280%	6.6s
300%	5.6s

High Inertia Series (ECMA G1 Series)

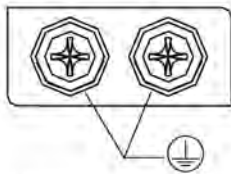
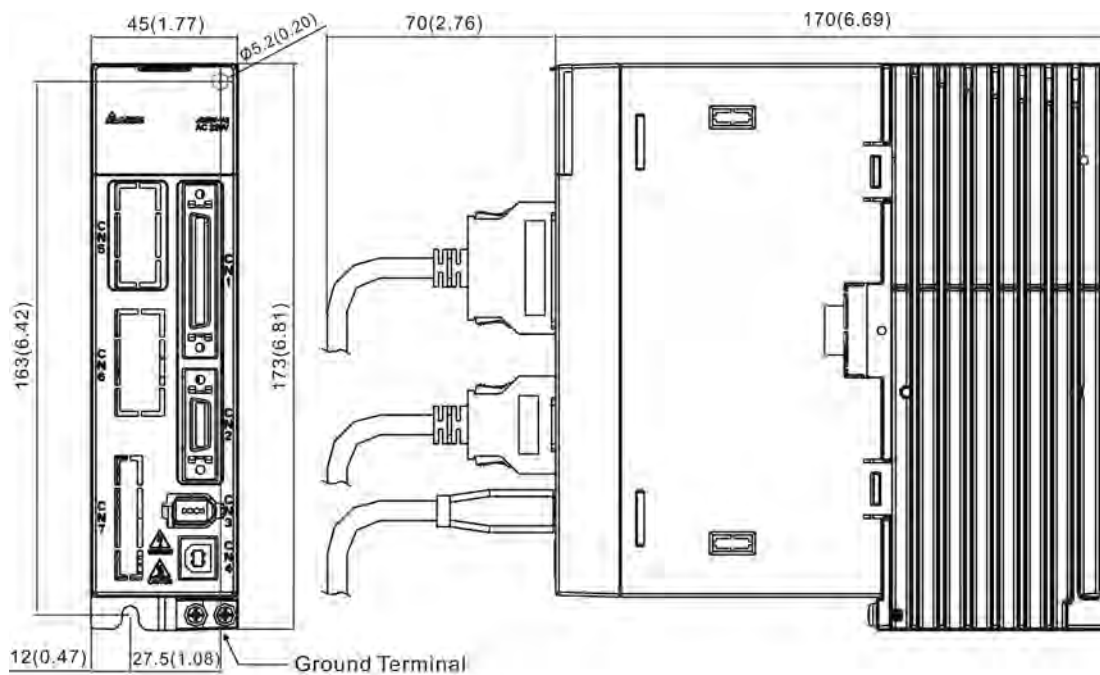


Load	Operating Time
120%	527.6s
140%	70.4s
160%	35.2s
180%	22.4s
200%	16s
220%	12.2s
240%	9.6s
260%	7.8s
280%	6.6s
300%	5.6s

11.5 Dimensions of Servo Drive

11.5.1 220V Series

Order P/N: ASD-A2-0221; ASD-A2-0421 (100W ~ 400W)



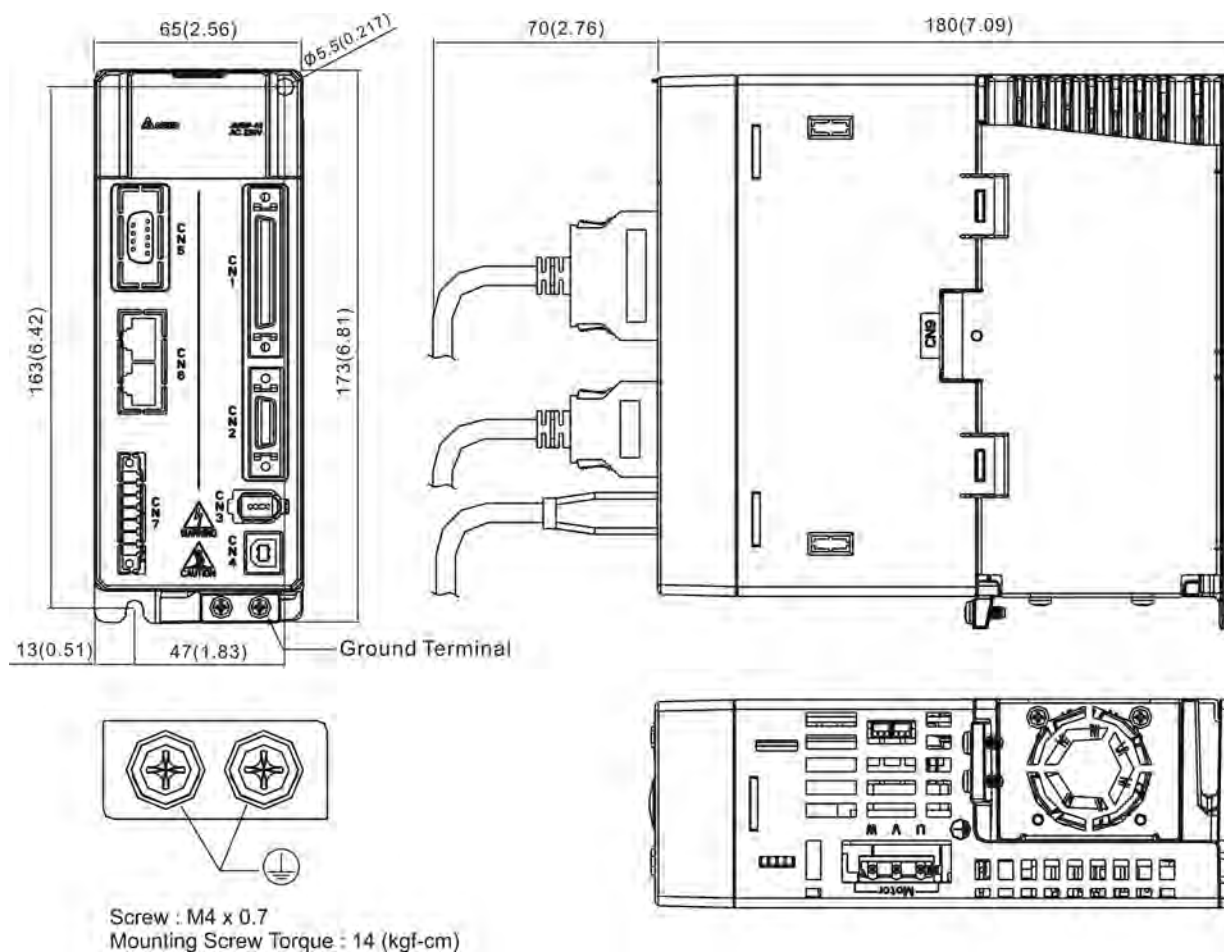
Screw : M4 x 0.7
 Mounting Screw Torque : 14 (kgf-cm)

WEIGHT
1.5 (3.3)

NOTE

- 1) Dimensions are in millimeters (inches); Weights are in kilograms (kg) and (pounds (lbs)).
- 2) Actual measured values are in metric units. Dimensions and weights in (imperial units) are for reference only.
- 3) Dimensions and weights of the servo drive may be revised without prior notice.

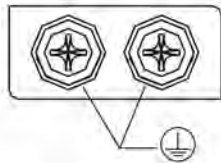
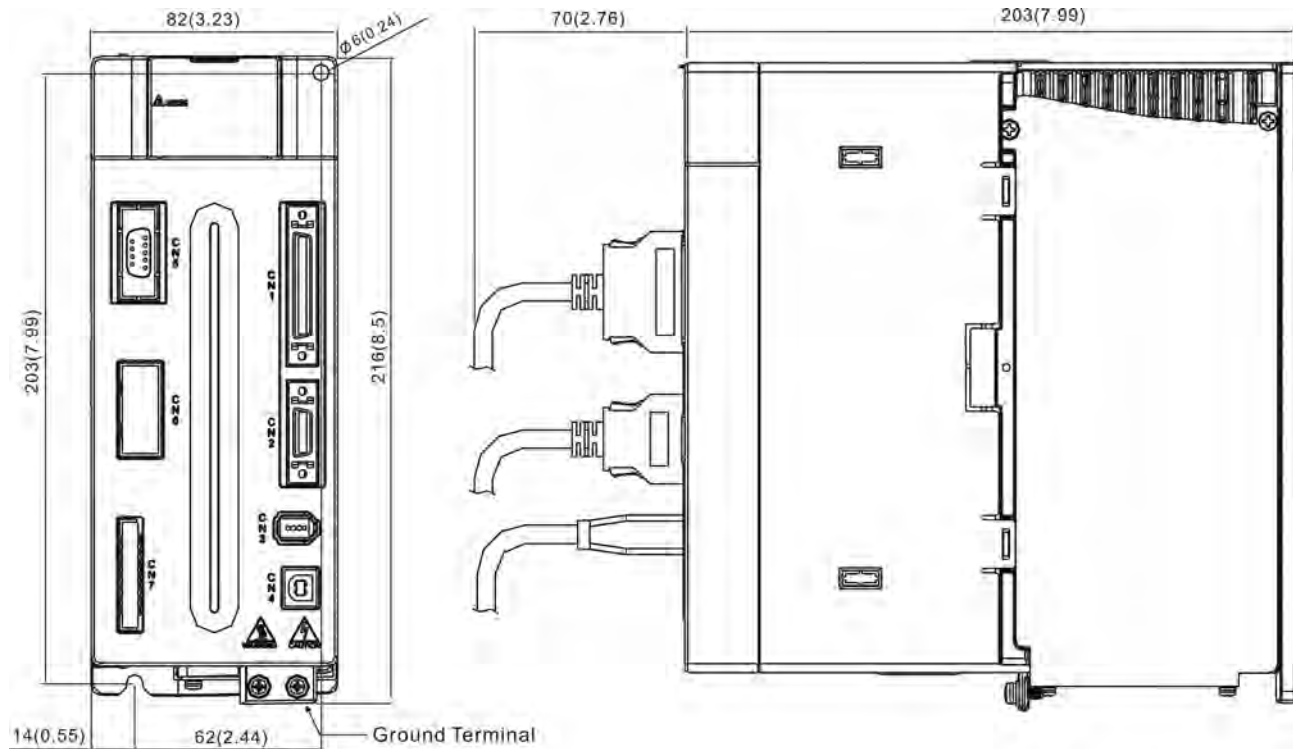
Order P/N: ASD-A2-0721; ASD-A2-1021; ASD-A2-1521 (750W ~ 1.5kW)



WEIGHT
2.0 (4.4)

NOTE

- 1) Dimensions are in millimeters (inches); Weights are in kilograms (kg) and (pounds (lbs)).
- 2) Actual measured values are in metric units. Dimensions and weights in (imperial units) are for reference only.
- 3) Dimensions and weights of the servo drive may be revised without prior notice.

Order P/N: ASD-A2-2023; ASD-A2-3023 (2kW ~ 3kW)

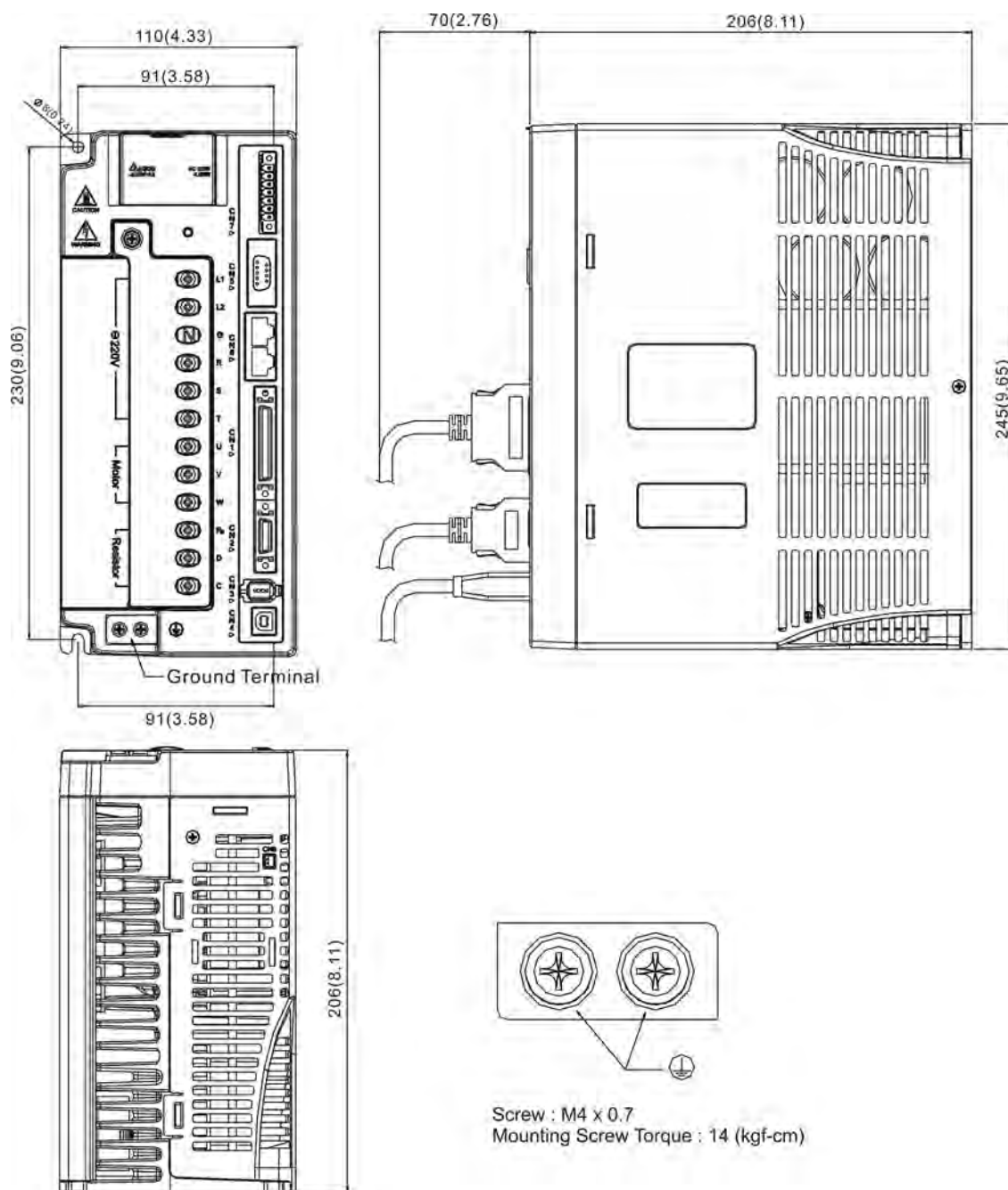
Screw : M4 x 0.7
 Mounting Screw Torque : 14 (kgf-cm)

WEIGHT
3.0 (6.6)

NOTE

- 1) Dimensions are in millimeters (inches); Weights are in kilograms (kg) and (pounds (lbs)).
- 2) Actual measured values are in metric units. Dimensions and weights in (imperial units) are for reference only.
- 3) Dimensions and weights of the servo drive may be revised without prior notice.

Order P/N: ASD-A2-4523 (4.5kW)

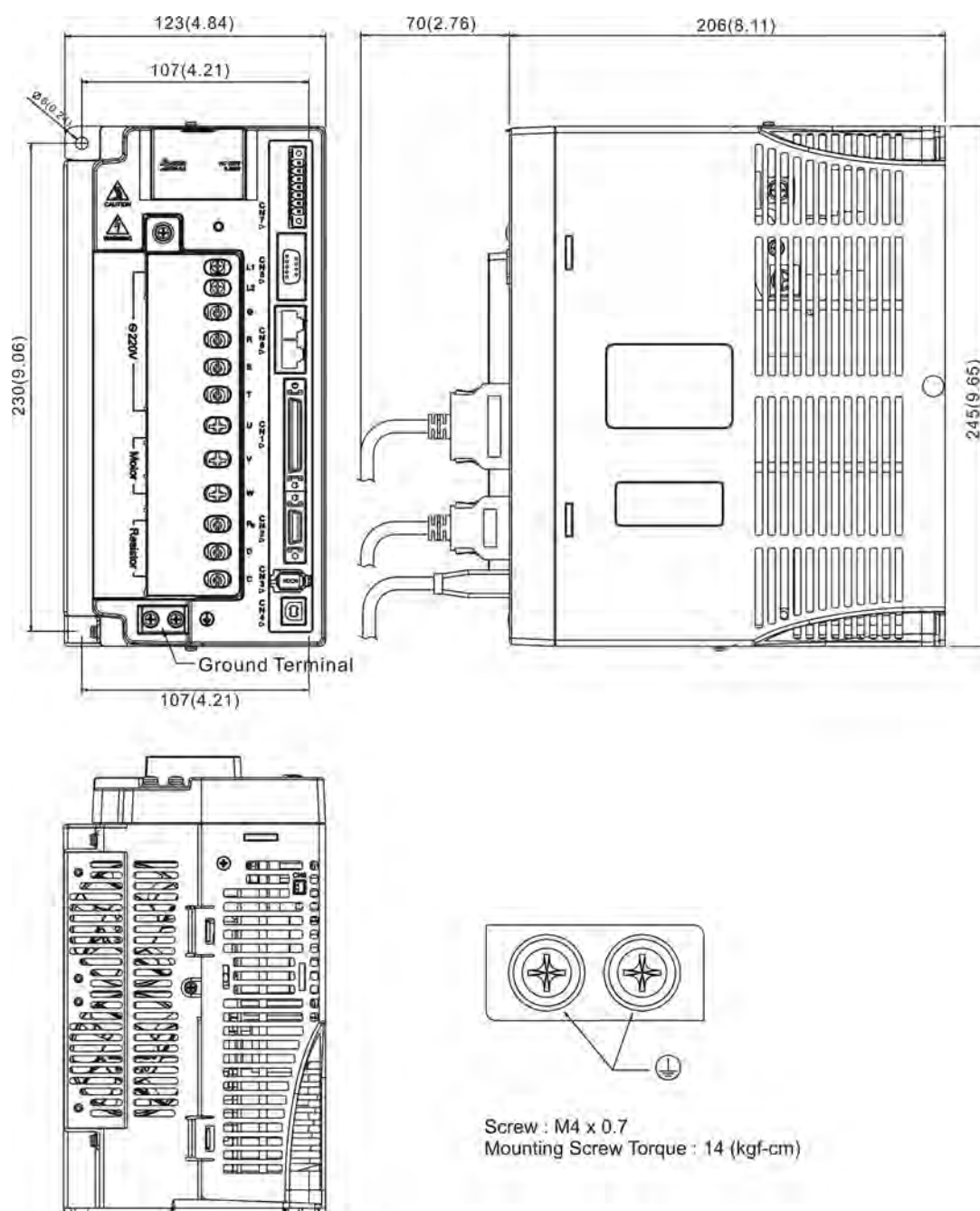


WEIGHT
4.4 (10.0)

NOTE

- 1) Dimensions are in millimeters (inches); Weights are in kilograms (kg) and (pounds (lbs)).
- 2) Actual measured values are in metric units. Dimensions and weights in (imperial units) are for reference only.
- 3) Dimensions and weights of the servo drive may be revised without prior notice.

Order P/N: ASD-A2-5523 (5.5kW)

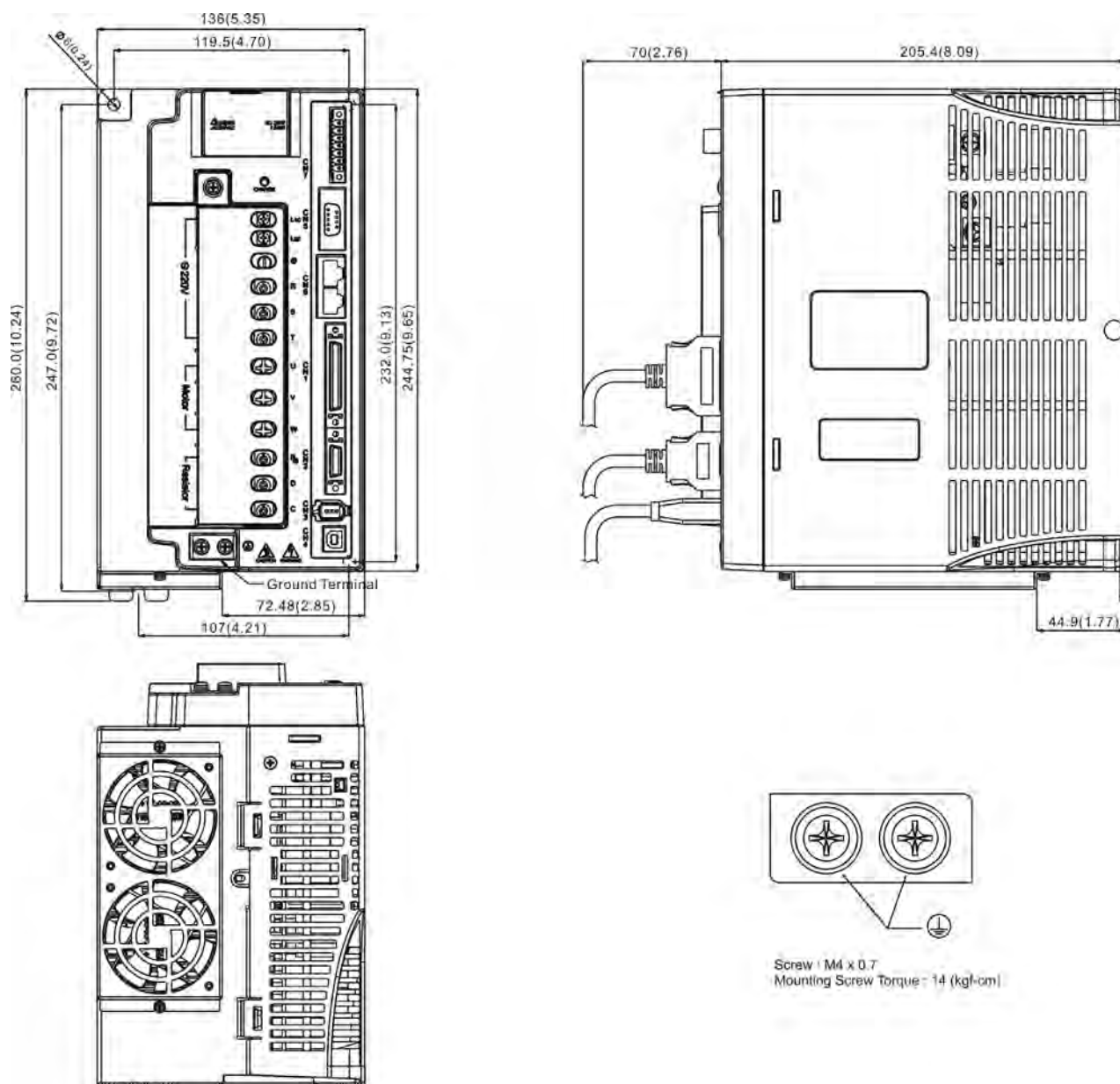


WEIGHT
5.5 (12.1)

NOTE

- 1) Dimensions are in millimeters (inches); Weights are in kilograms (kg) and (pounds (lbs)).
- 2) Actual measured values are in metric units. Dimensions and weights in (imperial units) are for reference only.
- 3) Dimensions and weights of the servo drive may be revised without prior notice.

Order P/N: ASDA-A2-7523 (7.5kW)



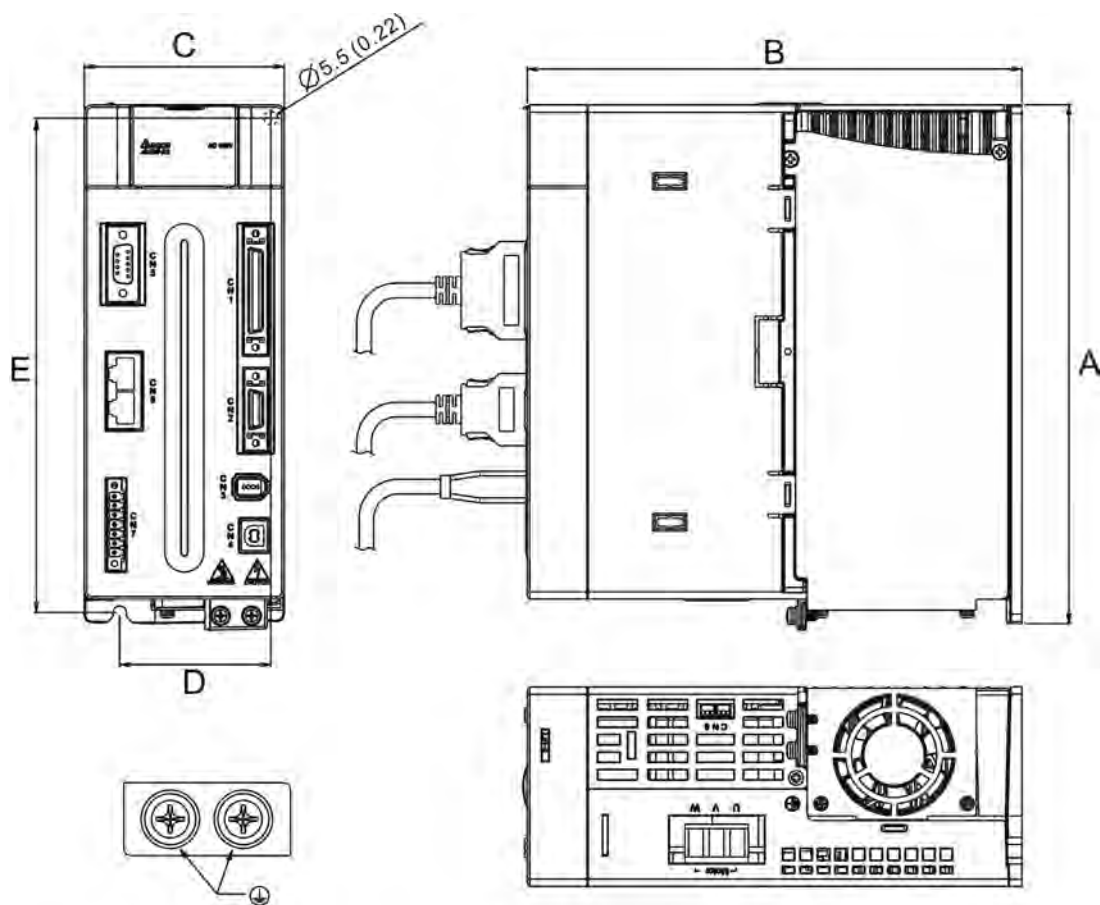
WEIGHT
5.9 (13.0)

NOTE

- 1) Dimensions are in millimeters (inches); Weights are in kilograms (kg) and (pounds (lbs)).
- 2) Actual measured values are in metric units. Dimensions and weights in (imperial units) are for reference only.
- 3) Dimensions and weights of the servo drive may be revised without prior notice.

11.5.2 400V Series

Order P/N: ASD-A2-0743; ASD-A2-1043; ASD-A2-1543 (750W ~ 1.5kW)



Screw: M4 x 0.7

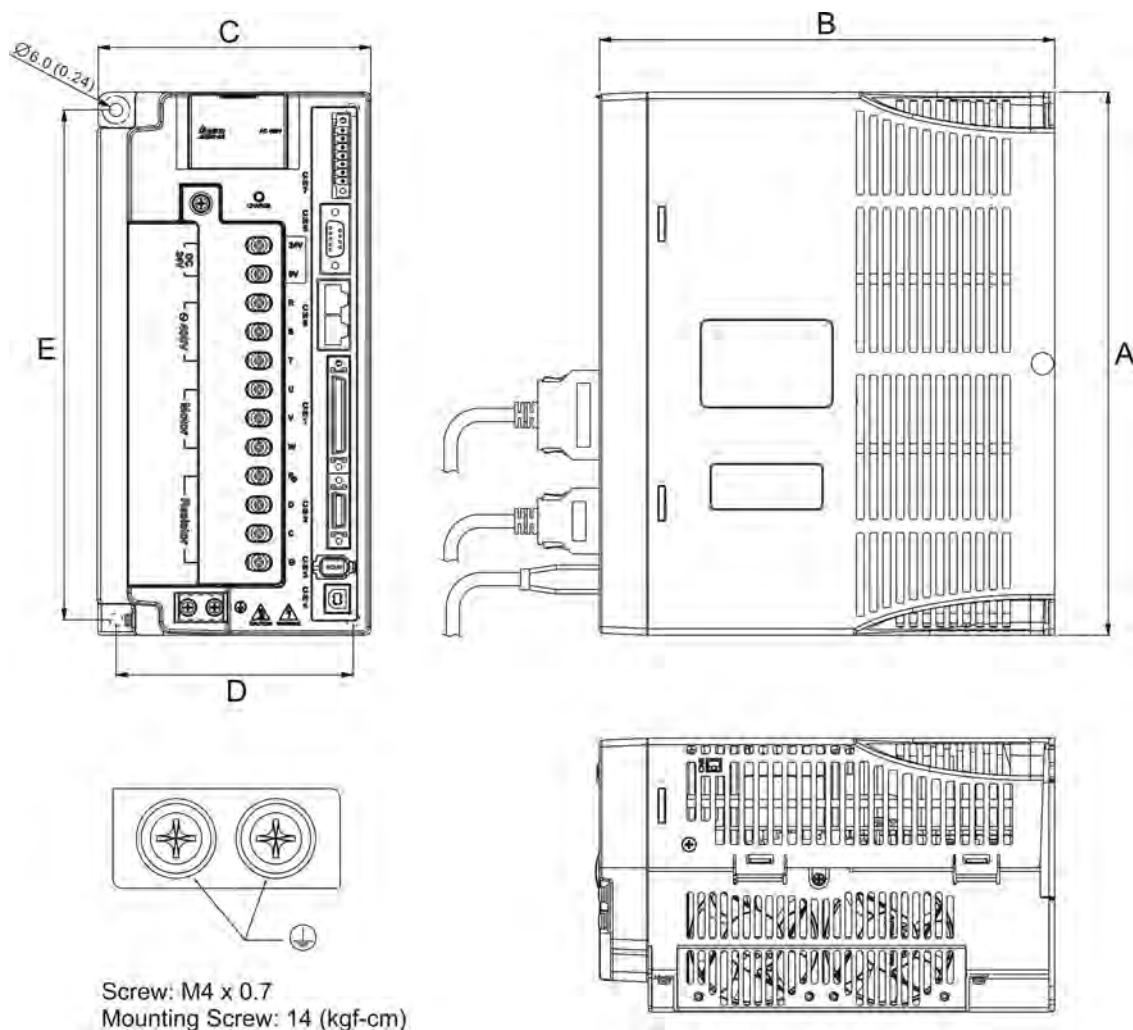
Mounting Screw: 14 (kgf-cm)

Power	A	B	C	D	E	Weight
750W ~ 1.5kW	216 (8.50)	203 (7.99)	82 (3.23)	62 (2.44)	203 (7.99)	2.89 (6.36)

 **NOTE**

- 1) Dimensions are in millimeters (inches); Weights are in kilograms (kg) and (pounds (lbs)).
- 2) Actual measured values are in metric units. Dimensions and weights in (imperial units) are for reference only.
- 3) Dimensions and weights of the servo drive may be revised without prior notice.

Order P/N: ASD-A2-2043; ASD-A2-3043, ASD-A2-4543; ASD-A2-5543 (2kW ~ 5.5kW)

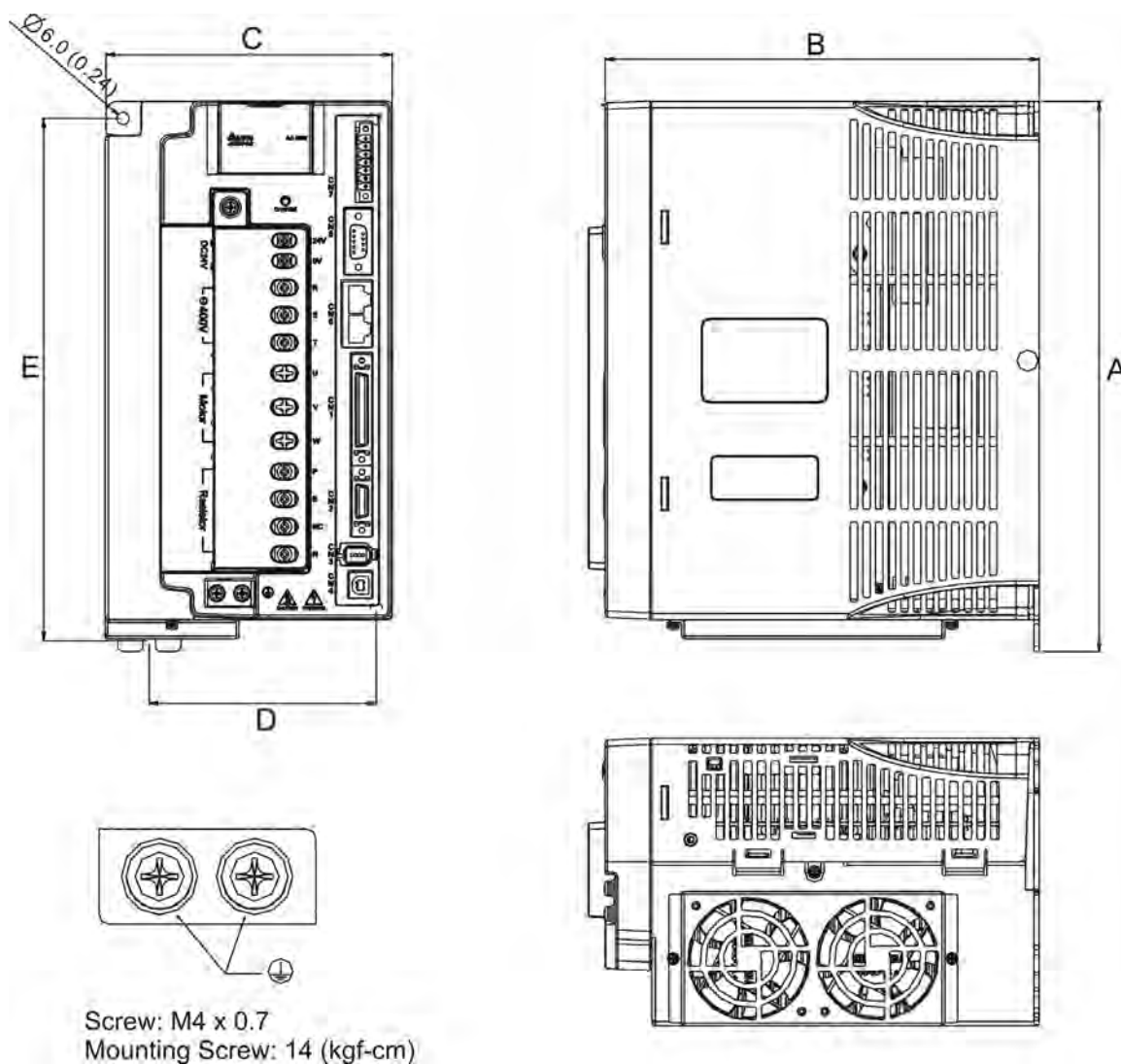


Power	A	B	C	D	E	Weight
2kW ~ 5.5kW	245 (9.65)	205.4 (8.11)	123 (4.88)	107 (4.21)	230 (9.06)	5.5 (12.1)

NOTE

- 1) Dimensions are in millimeters (inches); Weights are in kilograms (kg) and (pounds (lbs)).
- 2) Actual measured values are in metric units. Dimensions and weights in (imperial units) are for reference only.
- 3) Dimensions and weights of the servo drive may be revised without prior notice.

Order P/N: ASD-A2-7543 (7.5kW)



Power	A	B	C	D	E	Weight
7.5kW	260 (10.24)	205.4 (8.11)	136 (8.08)	107 (4.21)	247 (9.72)	6 (13.2)

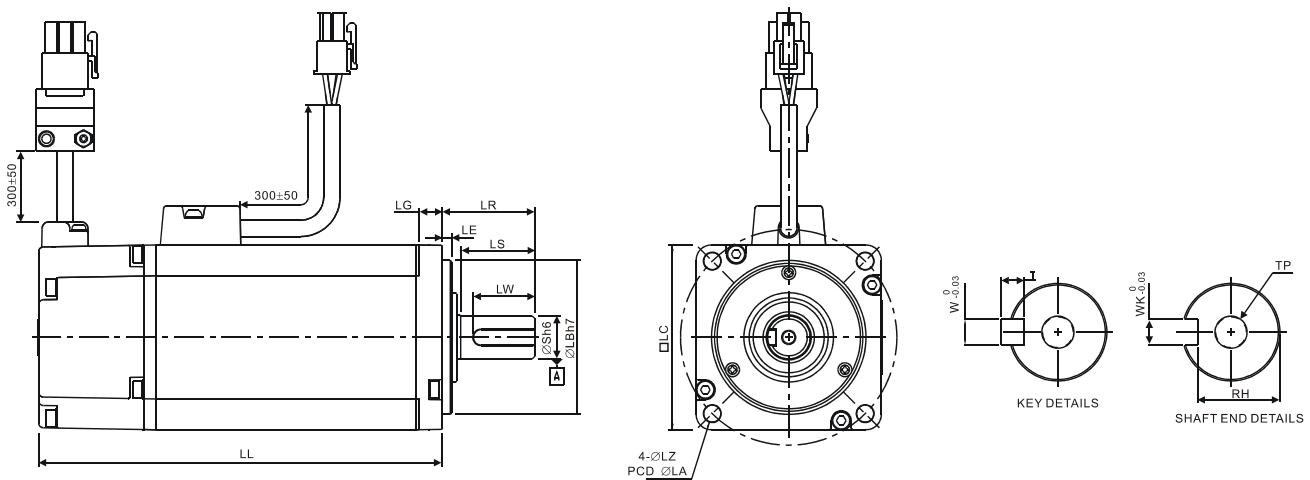
NOTE

- 1) Dimensions are in millimeters (inches); Weights are in kilograms (kg) and (pounds (lbs)).
- 2) Actual measured values are in metric units. Dimensions and weights in (imperial units) are for reference only.
- 3) Dimensions and weights of the servo drive may be revised without prior notice.

11.6 Dimensions of Servo Motors (ECMA Series)

11.6.1 220V Series

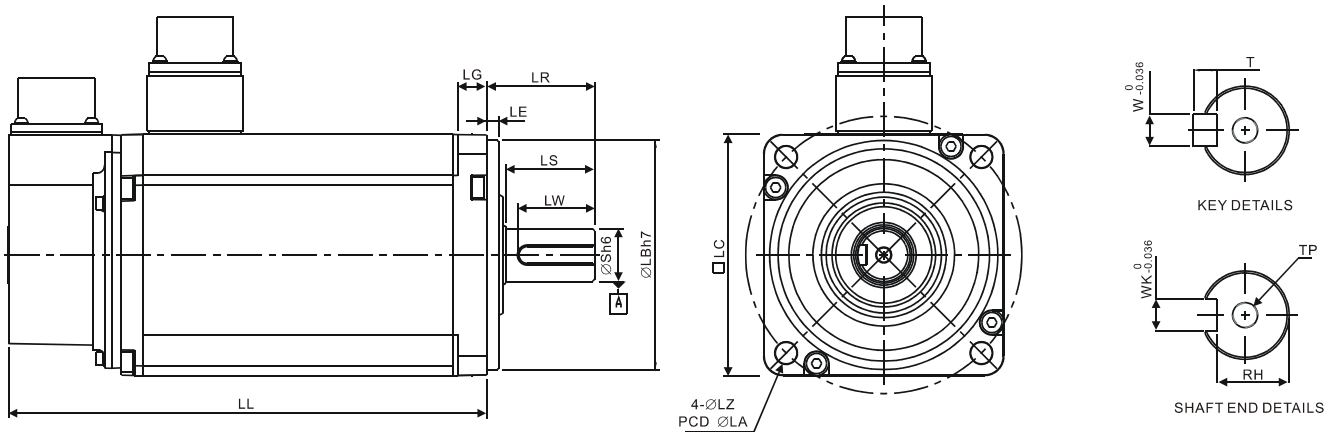
Motor Frame Size: 80mm and below Models - 220V series



Model	C10401□S	C10602□S	C10604□S	C10804□S	C10807□S
LC	40	60	60	80	80
LZ	4.5	5.5	5.5	6.6	6.6
LA	46	70	70	90	90
S	8 ⁽⁺⁰⁾ _(-0.009)	14 ⁽⁺⁰⁾ _(-0.011)	14 ⁽⁺⁰⁾ _(-0.011)	14 ⁽⁺⁰⁾ _(-0.011)	19 ⁽⁺⁰⁾ _(-0.013)
LB	30 ⁽⁺⁰⁾ _(-0.021)	50 ⁽⁺⁰⁾ _(-0.025)	50 ⁽⁺⁰⁾ _(-0.025)	70 ⁽⁺⁰⁾ _(-0.030)	70 ⁽⁺⁰⁾ _(-0.030)
LL (without brake)	100.6	105.5	130.7	112.3	138.3
LL (with brake)	136.6	141.6	166.8	152.8	178
LS (without oil seal)	20	27	27	27	32
LS (with oil seal)	20	24	24	24.5	29.5
LR	25	30	30	30	35
LE	2.5	3	3	3	3
LG	5	7.5	7.5	8	8
LW	16	20	20	20	25
RH	6.2	11	11	11	15.5
WK	3	5	5	5	6
W	3	5	5	5	6
T	3	5	5	5	6
TP	M3 Depth 8	M4 Depth 15	M4 Depth 15	M4 Depth 15	M6 Depth 20

NOTE

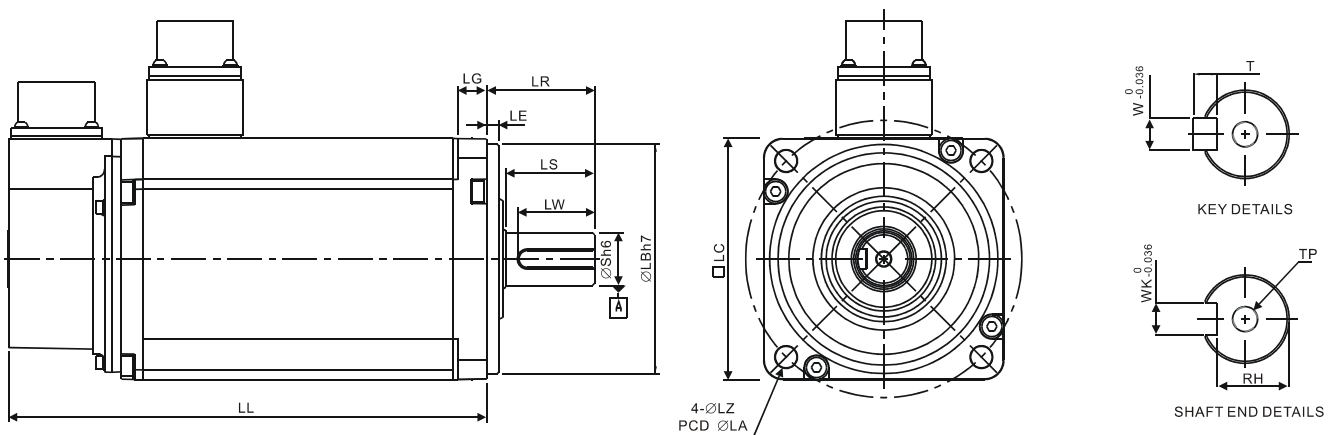
- 1) Dimensions are in millimeters.
- 2) Dimensions of the servo motor may be revised without prior notice.
- 3) The boxes (□) in the model names are for optional configurations. (Please refer to section 1.2 for model explanation.)
- 4) Actual measured values are in metric units.

Motor Frame Size: 100mm~130mm Models - 220V series

Model	G11303□S	E11305□S	G11306□S	G11309□S	C11010ES
LC	130	130	130	130	100
LZ	9	9	9	9	9
LA	145	145	145	145	115
S	22 ⁽⁺⁰⁾ _(-0.013)	22 ⁽⁺⁰⁾ _(-0.013)	22 ⁽⁺⁰⁾ _(-0.013)	22 ⁽⁺⁰⁾ _(-0.013)	22 ⁽⁺⁰⁾ _(-0.013)
LB	110 ⁽⁺⁰⁾ _(-0.035)	110 ⁽⁺⁰⁾ _(-0.035)	110 ⁽⁺⁰⁾ _(-0.035)	110 ⁽⁺⁰⁾ _(-0.035)	95 ⁽⁺⁰⁾ _(-0.035)
LL (without brake)	147.5	147.5	147.5	163.5	153.3
LL (with brake)	183.5	183.5	183.5	198	192.5
LS	47	47	47	47	37
LR	55	55	55	55	45
LE	6	6	6	6	5
LG	11.5	11.5	11.5	11.5	12
LW	36	36	36	36	32
RH	18	18	18	18	18
WK	8	8	8	8	8
W	8	8	8	8	8
T	7	7	7	7	7
TP	M6 Depth 20	M6 Depth 20	M6 Depth 20	M6 Depth 20	M6 Depth 20

NOTE

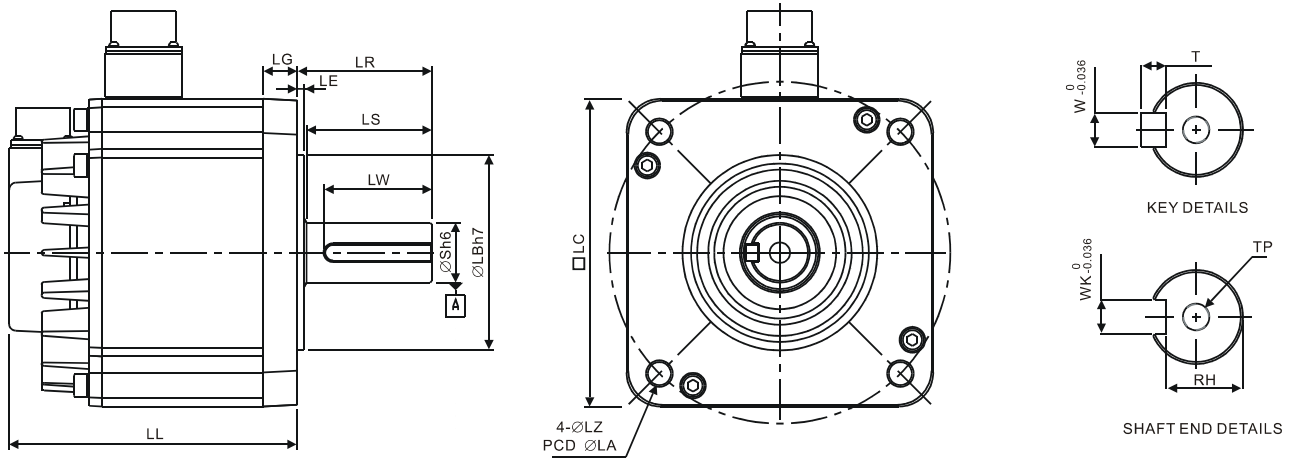
- 1) Dimensions are in millimeters.
- 2) Dimensions of the servo motor may be revised without prior notice.
- 3) The boxes (□) in the model names are for optional configurations. (Please refer to section 1.2 for model explanation.)
- 4) Actual measured values are in metric units.

Motor Frame Size: 100mm~130mm Models - **220V series**

Model	E11310□S	E11315□S	C11020□S	E11320□S
LC	130	130	100	130
LZ	9	9	9	9
LA	145	145	115	145
S	$22^{+0}_{-0.013}$	$22^{+0}_{-0.013}$	$22^{+0}_{-0.013}$	$22^{+0}_{-0.013}$
LB	$110^{+0}_{-0.035}$	$110^{+0}_{-0.035}$	$95^{+0}_{-0.035}$	$110^{+0}_{-0.035}$
LL (without brake)	147.5	167.5	199	187.5
LL (with brake)	183.5	202	226	216
LS	47	47	37	47
LR	55	55	45	55
LE	6	6	5	6
LG	11.5	11.5	12	11.5
LW	36	36	32	36
RH	18	18	18	18
WK	8	8	8	8
W	8	8	8	8
T	7	7	7	7
TP	M6 Depth 20	M6 Depth 20	M6 Depth 20	M6 Depth 20

 **NOTE**

- 1) Dimensions are in millimeters.
- 2) Dimensions of the servo motor may be revised without prior notice.
- 3) The boxes (□) in the model names are for optional configurations. (Please refer to section 1.2 for model explanation.)
- 4) Actual measured values are in metric units.

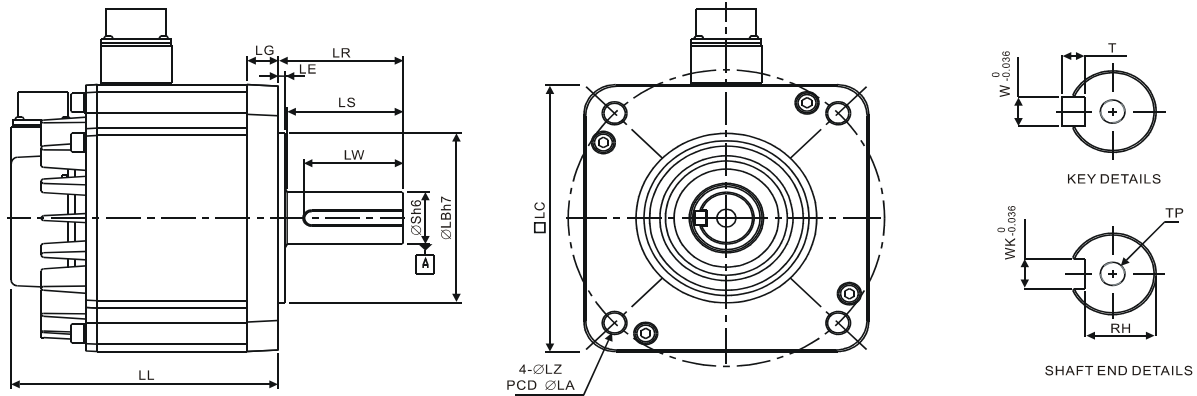
Motor Frame Size: 180mm and above Models - 220V series

Model	E11820□S	E11830□S	F11830□S
LC	180	180	180
LZ	13.5	13.5	13.5
LA	200	200	200
S	35 ⁽⁺⁰⁾ _(-0.016)	35 ⁽⁺⁰⁾ _(-0.016)	35 ⁽⁺⁰⁾ _(-0.016)
LB	114.3 ⁽⁺⁰⁾ _(-0.035)	114.3 ⁽⁺⁰⁾ _(-0.035)	114.3 ⁽⁺⁰⁾ _(-0.035)
LL (without brake)	169	202.1	202.1
LL (with brake)	203.1	235.3	235.3
LS	73	73	73
LR	79	79	79
LE	4	4	4
LG	20	20	20
LW	63	63	63
RH	30	30	30
WK	10	10	10
W	10	10	10
T	8	8	8
TP	M12 Depth 25	M12 Depth 25	M12 Depth 25

 **NOTE**

- 1) Dimensions are in millimeters.
- 2) Dimensions of the servo motor may be revised without prior notice.
- 3) The boxes (□) in the model names are for optional configurations. (Please refer to section 1.2 for model explanation.)
- 4) Actual measured values are in metric units.

Motor Frame Size: F1845mm and above Models - 220V series



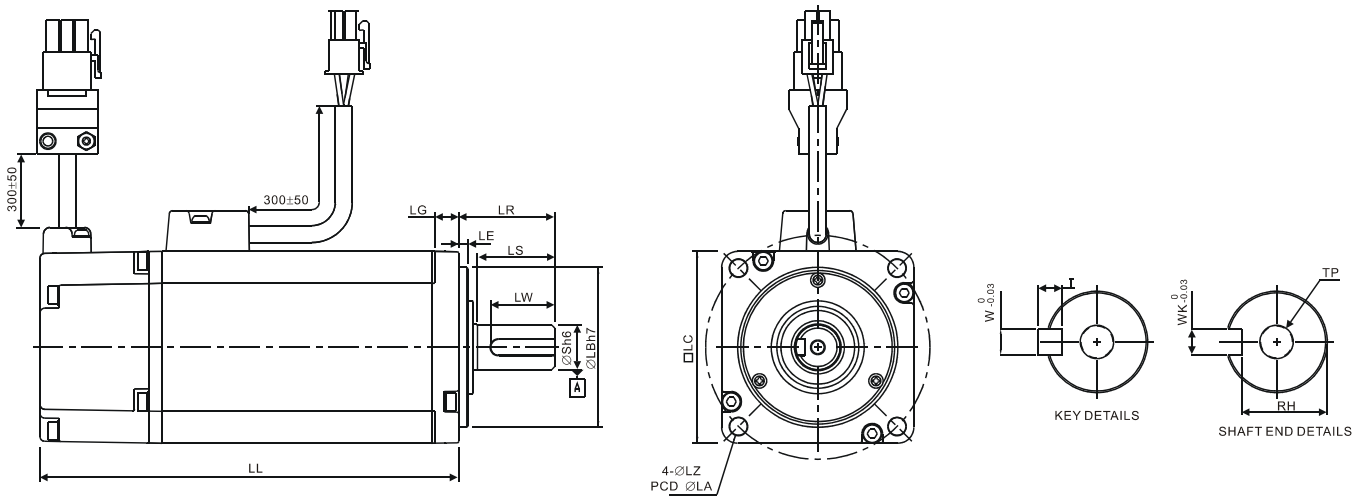
Model	F11845□S	F11855□3	F11875□3
LC	180	180	180
LZ	13.5	13.5	13.5
LA	200	200	200
S	35 ⁽⁺⁰⁾ _(-0.016)	42 ⁽⁺⁰⁾ _(-0.016)	42 ⁽⁺⁰⁾ _(-0.016)
LB	114.3 ⁽⁺⁰⁾ _(-0.035)	114.3 ⁽⁺⁰⁾ _(-0.035)	114.3 ⁽⁺⁰⁾ _(-0.035)
LL (without brake)	235.3	279.7	342.0
LL (with brake)	279.3	311.7	376.1
LS	73	108.5	113
LR	79	113	73
LE	4	4	4
LG	20	20	20
LW	63	90	90
RH	30	37	37
WK	10	12	12
W	10	12	12
T	8	8	8
TP	M12 Depth25	M16 Depth32	M16 Depth32

 **NOTE**

- 1) Dimensions are in millimeters.
- 2) Dimensions of the servo motor may be revised without prior notice.
- 3) The boxes (□) in the model names are for optional configurations. (Please refer to section 1.2 for model explanation.)
- 4) Actual measured values are in metric units.

11.6.2 400V Series

Motor Frame Size: 80mm and below Models - 400V series

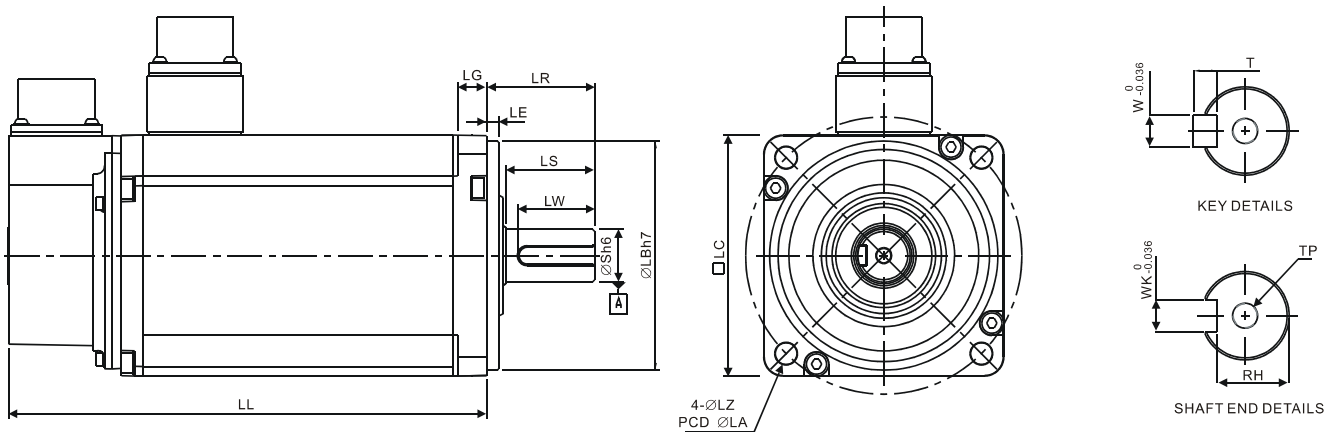


Model	J10807□S
LC	80
LZ	6.6
LA	90
S	19 ⁽⁺⁰⁾ _(-0.013)
LB	70 ⁽⁺⁰⁾ _(-0.030)
LL (Without Brake)	138.3
LL (With Brake)	178
LS (Without Oil Seal)	32
LS (With Oil Seal)	29.5
LR	35
LE	3
LG	8
LW	25
RH	15.5
WK	6
W	6
T	6
TP	M6, Depth 20

 **NOTE**

- 1) Dimensions are in millimeters.
- 2) Dimensions of the servo motor may be revised without prior notice.
- 3) The boxes (□) in the model names are for optional configurations. (Please refer to section 1.2 for model explanation.)
- 4) Actual measured values are in metric units.

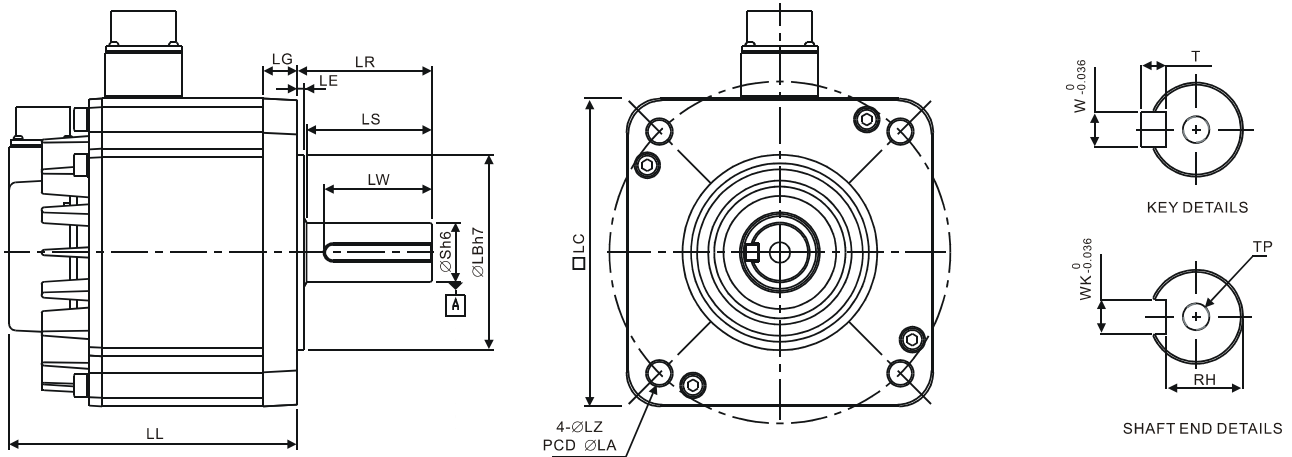
Motor Frame Size: 130mm Models - 400V series



Model	K11310□S	K11315□S	K11320□S
LC	130	130	130
LZ	9	9	9
LA	145	145	145
S	$22^{+0}_{-0.013}$	$22^{+0}_{-0.013}$	$22^{+0}_{-0.013}$
LB	$110^{+0}_{-0.035}$	$110^{+0}_{-0.035}$	$110^{+0}_{-0.035}$
LL (Without Brake)	147.5	167.5	187.5
LL (With Brake)	183.5	202	216
LS	47	47	47
LR	55	55	55
LE	6	6	6
LG	11.5	11.5	11.5
LW	36	36	36
RH	18	18	18
WK	8	8	8
W	8	8	8
T	7	7	7
TP	M6, Depth 20	M6, Depth 20	M6, Depth 20

 **NOTE**

- 1) Dimensions are in millimeters.
- 2) Dimensions of the servo motor may be revised without prior notice.
- 3) The boxes (□) in the model names are for optional configurations. (Please refer to section 1.2 for model explanation.)
- 4) Actual measured values are in metric units.

Motor Frame Size: 180mm and above Models - 400V series

Model	L11830□S	L11845□S	L11855□3	L11875□3
LC	180	180	180	180
LZ	13.5	13.5	13.5	13.5
LA	200	200	200	200
S	35 ⁽⁺⁰⁾ _(-0.016)	35 ⁽⁺⁰⁾ _(-0.016)	42 ⁽⁺⁰⁾ _(-0.016)	42 ⁽⁺⁰⁾ _(-0.016)
LB	114.3 ⁽⁺⁰⁾ _(-0.035)	114.3 ⁽⁺⁰⁾ _(-0.035)	114.3 ⁽⁺⁰⁾ _(-0.035)	114.3 ⁽⁺⁰⁾ _(-0.035)
LL (Without Brake)	202.1	235.3	279.7	342.0
LL (With Brake)	235.3	279.3	311.7	376.1
LS	73	73	108.5	108.5
LR	79	79	113	113
LE	4	4	4	4
LG	20	20	20	20
LW	63	63	90	90
RH	30	30	37	37
WK	10	10	12	12
W	10	10	12	12
T	8	8	8	8
TP	M12, Depth 25	M12, Depth 25	M16, Depth 32	M16, Depth 32

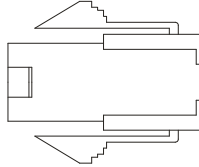
 **NOTE**

- 1) Dimensions are in millimeters.
- 2) Dimensions of the servo motor may be revised without prior notice.
- 3) The boxes (□) in the model names are for optional configurations. (Please refer to section 1.2 for model explanation.)
- 4) Actual measured values are in metric units.

Appendix A Accessories

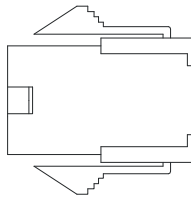
■ Power Connectors

Delta Part Number: ASDBCAPW0000



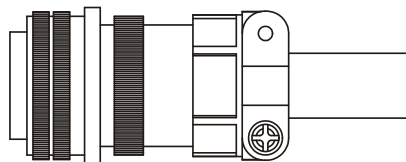
Title	Part No.	Manufacturer
Housing	C4201H00-2*2PA	JOWLE
Terminal	C4201TOP-2	JOWLE

Delta Part Number: ASDBCAPW0100



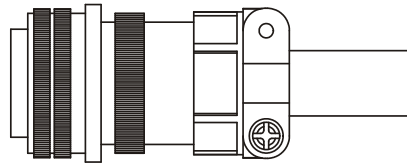
Title	Part No.	Manufacturer
Housing	C4201H00-2*3PA	JOWLE
Terminal	C4201TOP-2	JOWLE

Delta Part Number: ASD-CAPW1000



3106A-20-18S

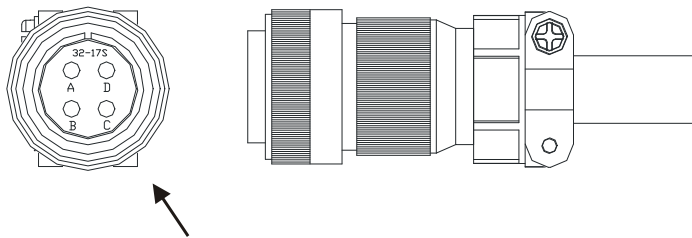
Delta Part Number: ASD-CAPW2000



3106A-24-11S

Delta Part Number: ASD-CAPW4000 (for **220V series** 5.5kW and above models)

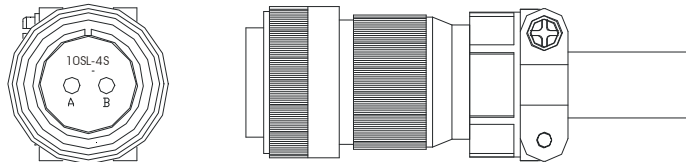
CLAMP: WPS3057-20A



Straight Plug WPS3106A-32-17S

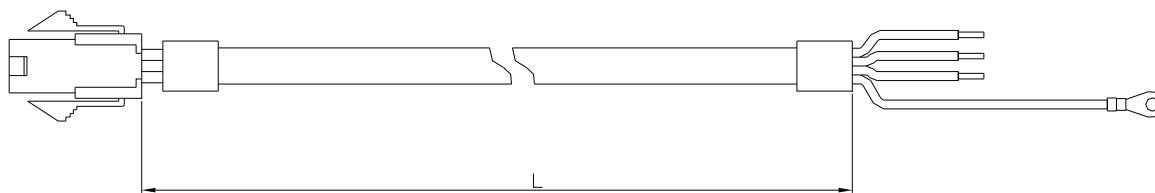
Motor Brake Connector: ASD-CNBR1000 (for **220V series** 5.5kW and above models)

CLAMP: WPS3106A 10SL-4S-R



■ **Power Cables**

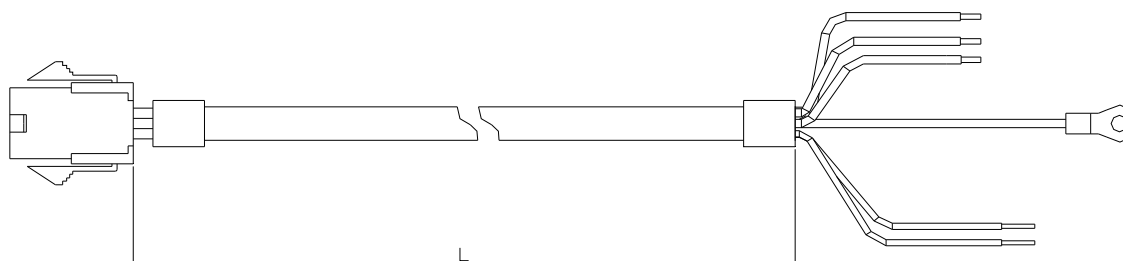
Delta Part Number: ASD-ABPW0003, ASD-ABPW0005



Title	Part No.	Manufacturer
Housing	C4201H00-2*2PA	JOWLE
Terminal	C4201TOP-2	JOWLE

Title	Part No.	L	
		mm	inch
1	ASD-ABPW0003	3000 ± 100	118 ± 4
2	ASD-ABPW0005	5000 ± 100	197 ± 4

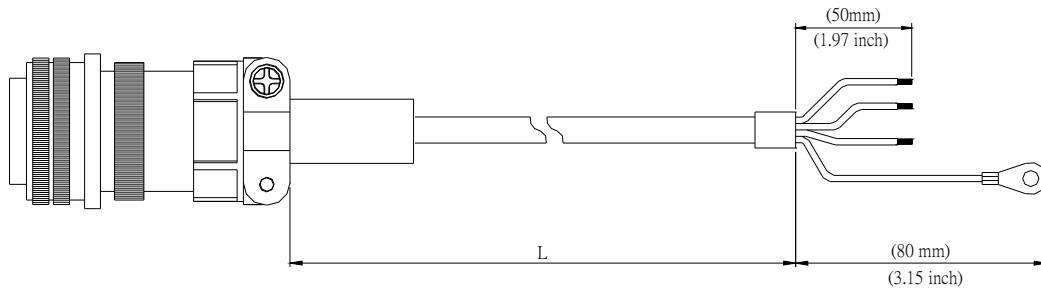
Delta Part Number: ASD-ABPW0103, ASD-ABPW0105



Title	Part No.	Manufacturer
Housing	C4201H00-2*3PA	JOWLE
Terminal	C4201TOP-2	JOWLE

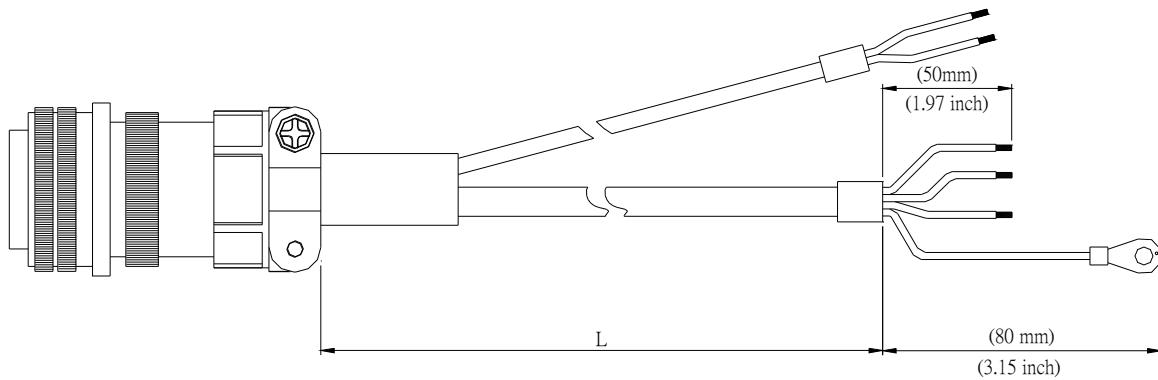
Title	Part No.	L	
		mm	inch
1	ASD-ABPW0103	3000 ± 100	118 ± 4
2	ASD-ABPW0105	5000 ± 100	197 ± 4

Delta Part Number: ASD-CAPW1003, ASD-CAPW1005



Title	Part No.	Straight	L	
			mm	inch
1	ASD-CAPW1003	3106A-20-18S	3000 ± 100	118 ± 4
2	ASD-CAPW1005	3106A-20-18S	5000 ± 100	197 ± 4

Delta Part Number: ASD-CAPW1103, ASD-CAPW1105

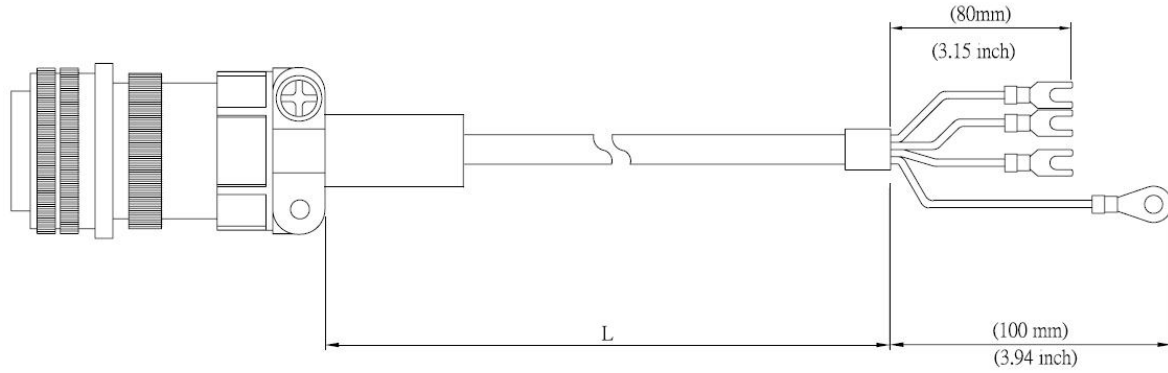


Title	Part No.	Straight	L	
			mm	inch
1	ASD-CAPW1103	3106A-20-18S	3000 ± 100	118 ± 4
2	ASD-CAPW1105	3106A-20-18S	5000 ± 100	197 ± 4

ASDA-A2

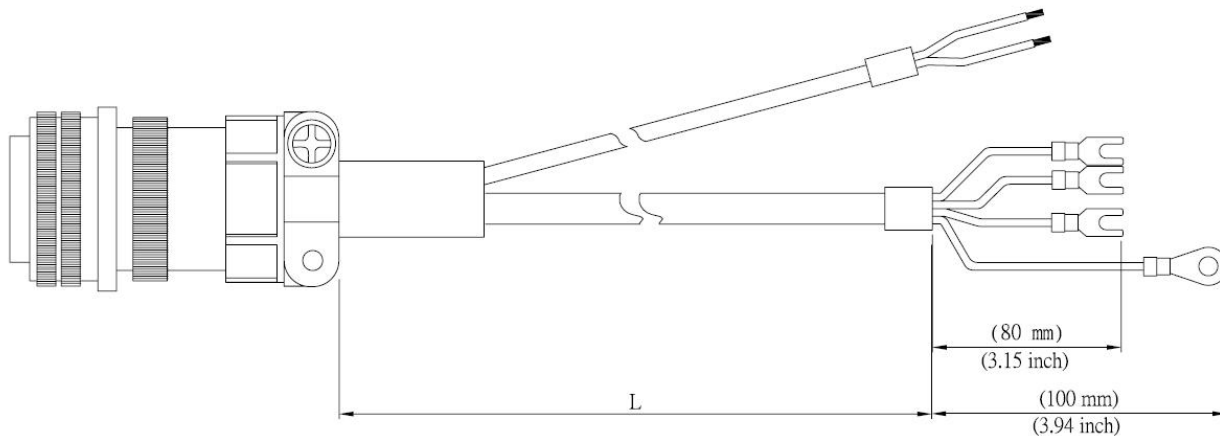
Appendix A Accessories

Delta Part Number: ASD-CAPW1203, ASD-CAPW1205



Title	Part No.	Straight	L	
			mm	inch
1	ASD-CAPW1203	3106A-20-18S	3000 ± 100	118 ± 4
2	ASD-CAPW1205	3106A-20-18S	5000 ± 100	197 ± 4

Delta Part Number: ASD-CAPW1303, ASD-CAPW1305

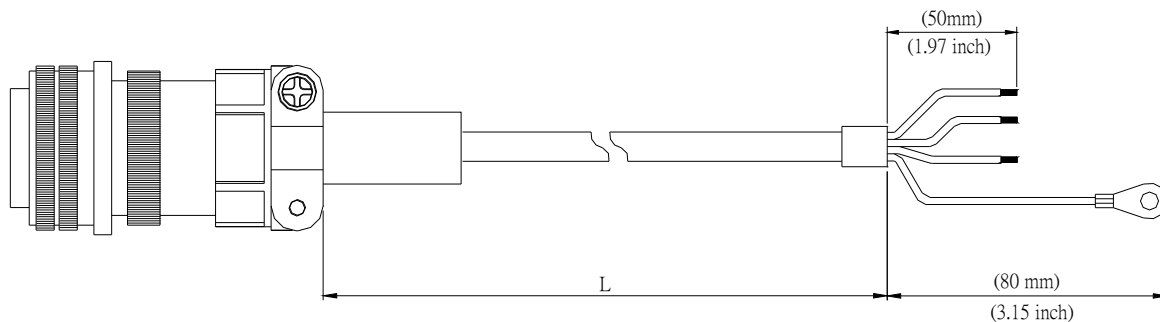


Title	Part No.	Straight	L	
			mm	inch
1	ASD-CAPW1303	3106A-20-18S	3000 ± 100	118 ± 4
2	ASD-CAPW1305	3106A-20-18S	5000 ± 100	197 ± 4

Appendix A Accessories

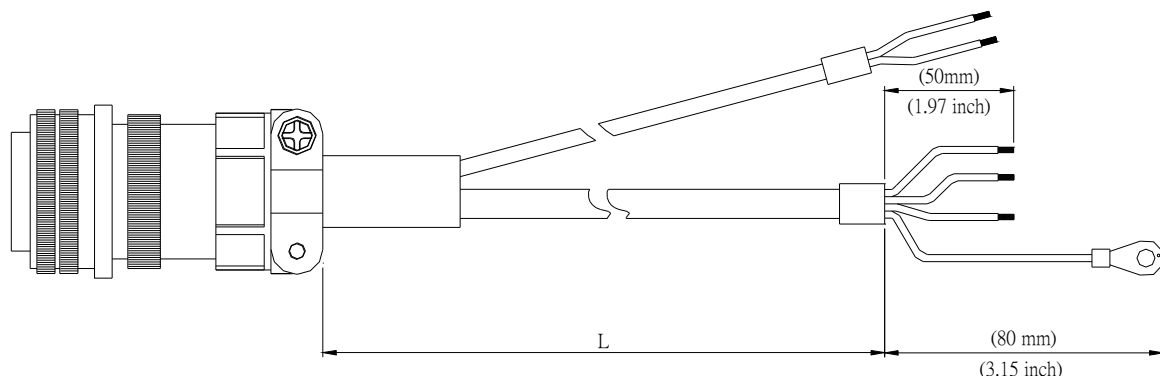
ASDA-A2

Delta Part Number: ASD-A2PW1003, ASD-A2PW1005



Title	Part No.	Straight	L	
			mm	inch
1	ASD-A2PW1003	3106A-20-18S	3000 ± 100	118 ± 4
2	ASD-A2PW1005	3106A-20-18S	5000 ± 100	197 ± 4

Delta Part Number: ASD-A2PW1103, ASD-A2PW1105

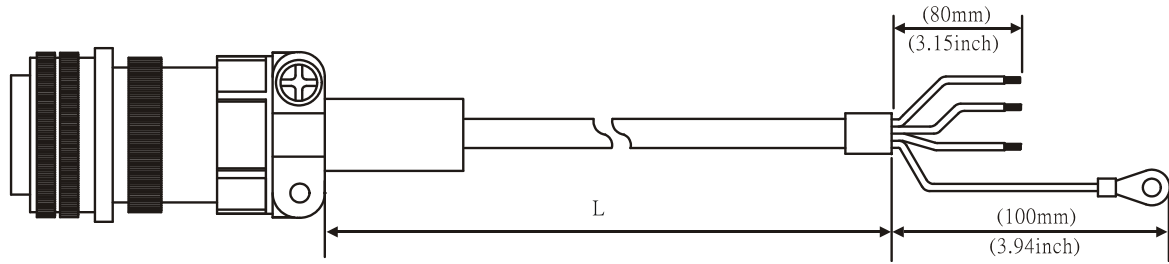


Title	Part No.	Straight	L	
			mm	inch
1	ASD-A2PW1103	3106A-20-18S	3000 ± 100	118 ± 4
2	ASD-A2PW1105	3106A-20-18S	5000 ± 100	197 ± 4

ASDA-A2

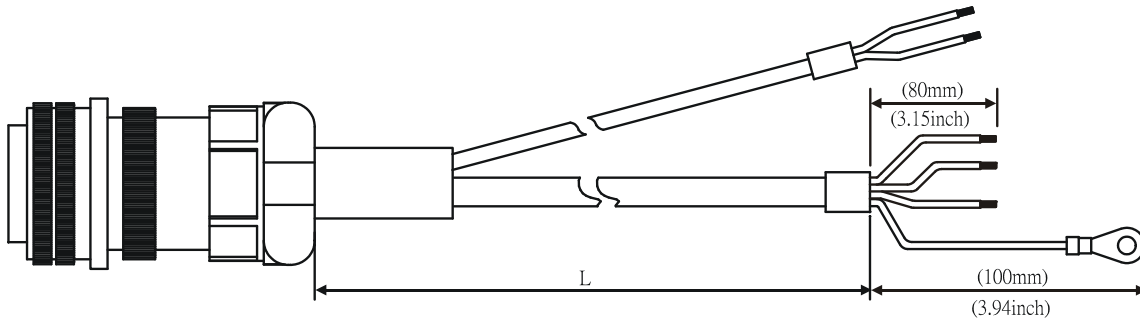
Appendix A Accessories

Delta Part Number: ASD-CAPW2003, ASD-CAPW2005



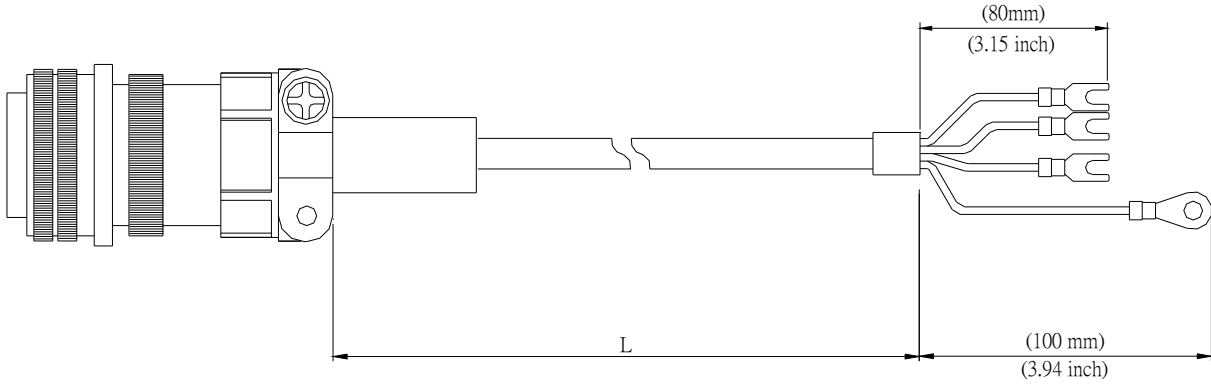
Title	Part No.	Straight	L	
			mm	inch
1	ASD-CAPW2003	3106A-24-11S	3000 ± 100	118 ± 4
2	ASD-CAPW2005	3106A-24-11S	5000 ± 100	197 ± 4

Delta Part Number: ASD-CAPW2103, ASD-CAPW2105



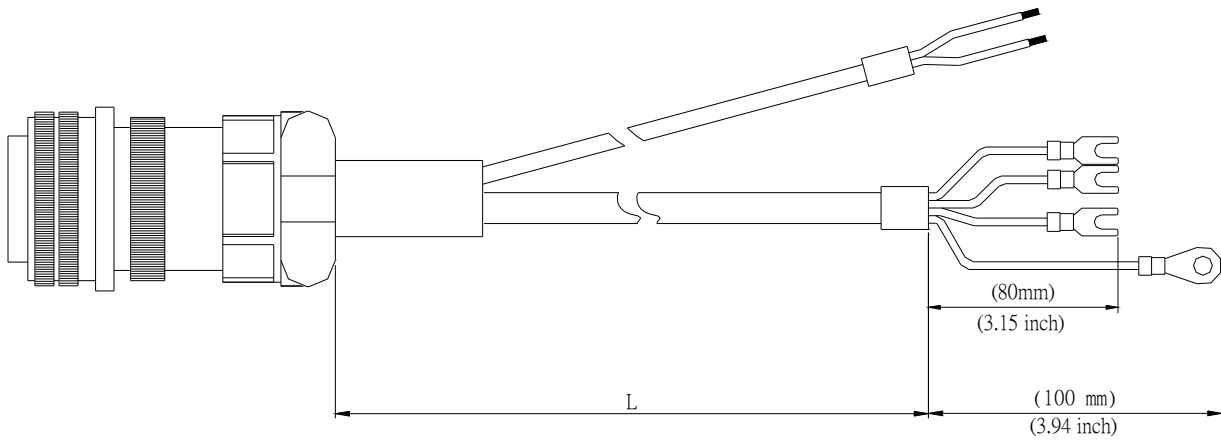
Title	Part No.	Straight	L	
			mm	inch
1	ASD-CAPW2103	3106A-24-11S	3000 ± 100	118 ± 4
2	ASD-CAPW2105	3106A-24-11S	5000 ± 100	197 ± 4

Delta Part Number: ASD-CAPW2203, ASD-CAPW2205



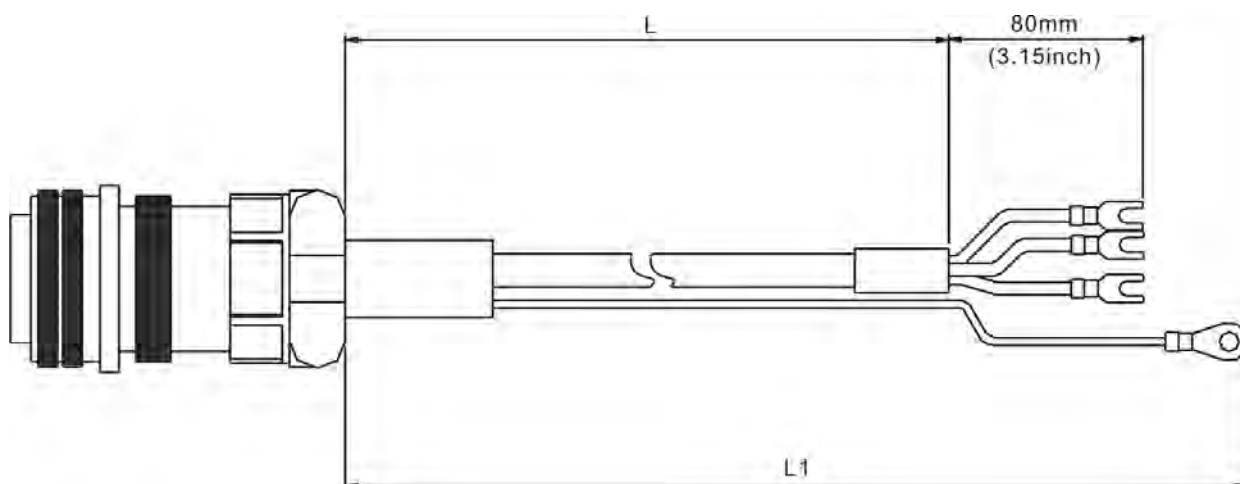
Title	Part No.	Straight	L	
			mm	inch
1	ASD-CAPW2203	3106A-24-11S	3000 ± 100	118 ± 4
2	ASD-CAPW2205	3106A-24-11S	5000 ± 100	197 ± 4

Delta Part Number: ASD-CAPW2303, ASD-CAPW2305 (for motors with brake)



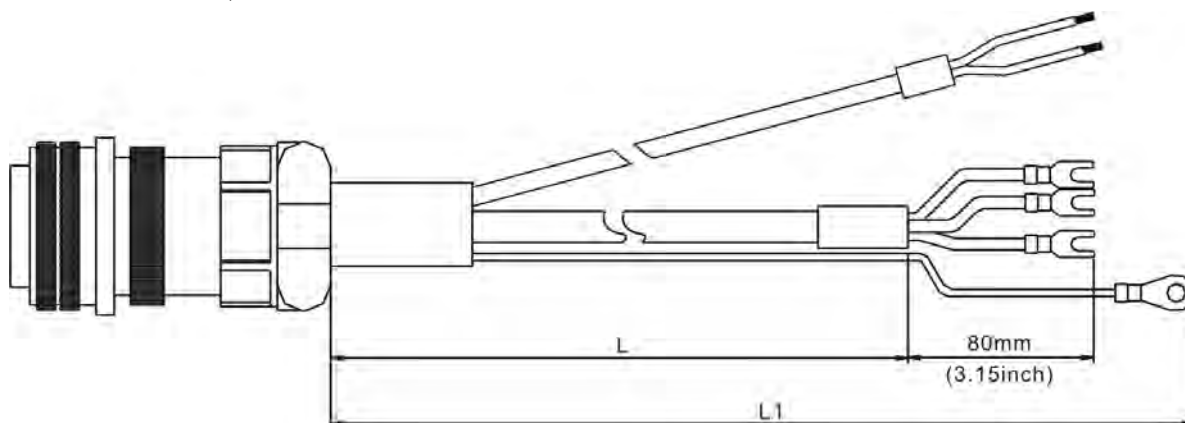
Title	Part No.	Straight	L	
			mm	inch
1	ASD-CAPW2303	3106A-24-11S	3000 ± 100	118 ± 4
2	ASD-CAPW2305	3106A-24-11S	5000 ± 100	197 ± 4

Delta Part Number: ASD-CAPW3203, ASD-CAPW3205 (for 4.5kW models)



Item	Part No.	Straight	L		L1	
			mm	inch	mm	inch
1	ASD-CAPW3203	MS 3106-24-11S	3000 ± 100	118 ± 4	3100 ± 100	122 ± 4
2	ASD-CAPW3205	MS 3106-24-11S	5000 ± 100	197 ± 4	5100 ± 100	201 ± 4

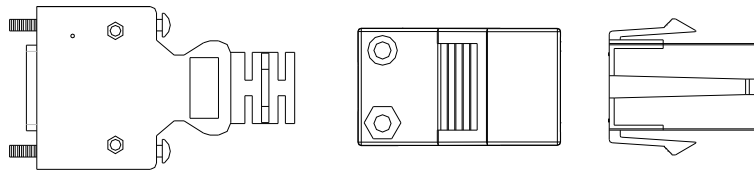
**Delta Part Number: ASD-CAPW3303, ASD-CAPW3305 (for motors with brake)
(for 4.5kW models)**



Item	Part No.	Straight	L		L1	
			mm	inch	mm	inch
1	ASD-CAPW3303	MS 3106-24-11S	3000 ± 100	118 ± 4	3100 ± 100	122 ± 4
2	ASD-CAPW3305	MS 3106-24-11S	5000 ± 100	197 ± 4	5100 ± 100	201 ± 4

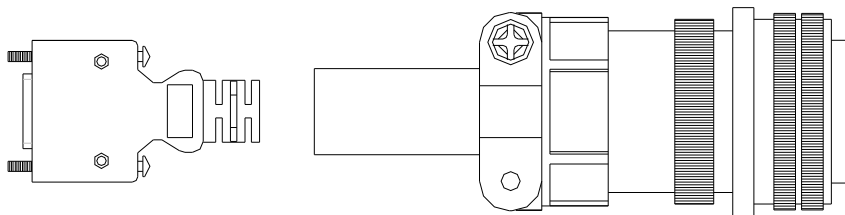
Encoder Connectors

Delta Part Number: ASD-ABEN0000



Title		Part No.	Manufacturer
MOTOR SIDE	Housing	AMP (1-172161-9)	AMP
	Terminal	AMP (170359-3)	AMP
	CLAMP	DELTA (34703237XX)	DELTA
DRIVE SIDE	PLUG	3M 10120-3000PE	3M
	SHELL	3M 10320-52A0-008	3M

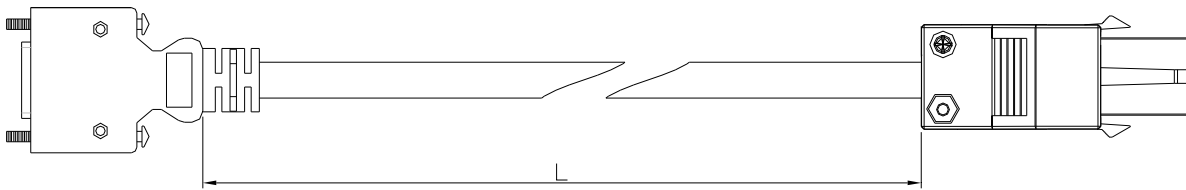
Delta Part Number: ASD-CAEN1000



Title		Part No.	Manufacturer
MOTOR SIDE		3106A-20-29S	-
DRIVE SIDE	PLUG	3M 10120-3000PE	3M
	SHELL	3M 10320-52A0-008	3M

■ **Encoder Cables**

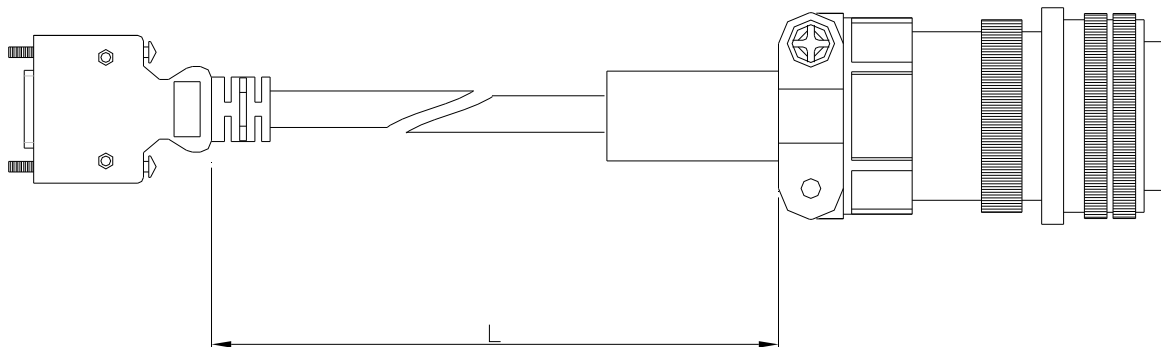
Delta Part Number: ASD-ABEN0003, ASD-ABEN0005



Title		Part No.	Manufacturer
MOTOR SIDE	Housing	AMP (1-172161-9)	AMP
	Terminal	AMP (170359-3)	AMP
	CLAMP	DELTA (34703237XX)	DELTA
DRIVE SIDE	PLUG	3M 10120-3000PE	3M
	SHELL	3M 10320-52A0-008	3M

Title	Part No.	L	
		mm	inch
1	ASD-ABEN0003	3000 ± 100	118 ± 4
2	ASD-ABEN0005	5000 ± 100	197 ± 4

Delta Part Number: ASD-CAEN1003, ASD-CAEN1005



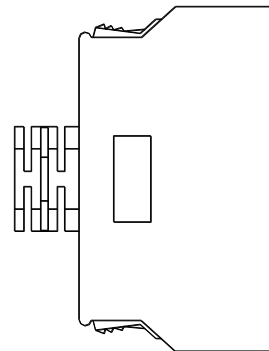
Title		Part No.	Manufacturer
MOTOR SIDE		3106A-20-29S	-
DRIVE SIDE	PLUG	3M 10120-3000PE	3M
	SHELL	3M 10320-52A0-008	3M

Title	Part No.	Straight	L	
			mm	inch
1	ASD-CAEN1003	3106A-20-29S	3000 ± 100	118 ± 4
2	ASD-CAEN1005	3106A-20-29S	5000 ± 100	197 ± 4

■ I/O Signal Connector (CN1)

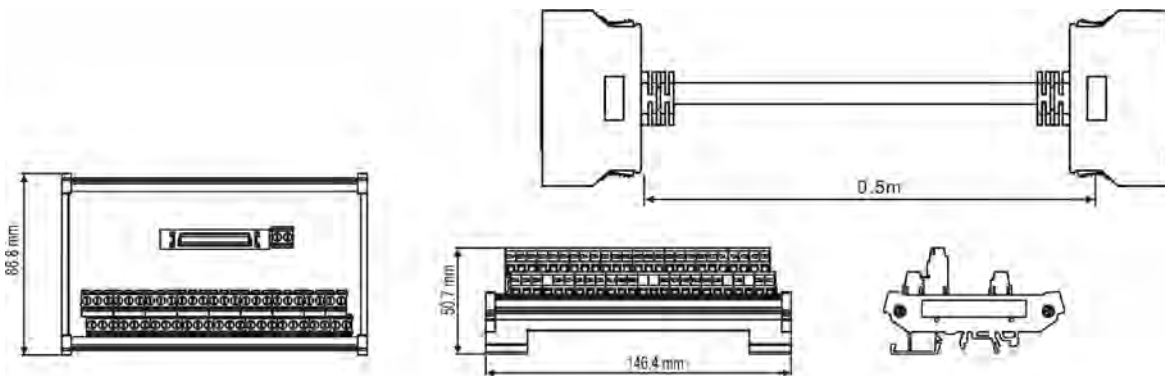
Delta Part Number: ASD-CN50050

Vendor Name	Vendor P/N
3M TAIWAN LTD	10150-3000PE
3M TAIWAN LTD	10350-52A0-008



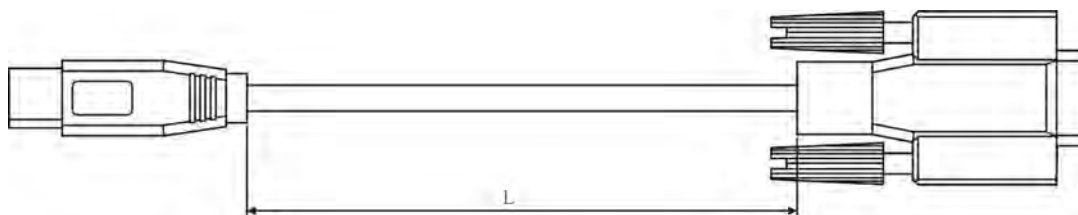
■ Terminal Block Module

Delta Part Number: ASD-BM-50A



■ RS-232 Communication Cable

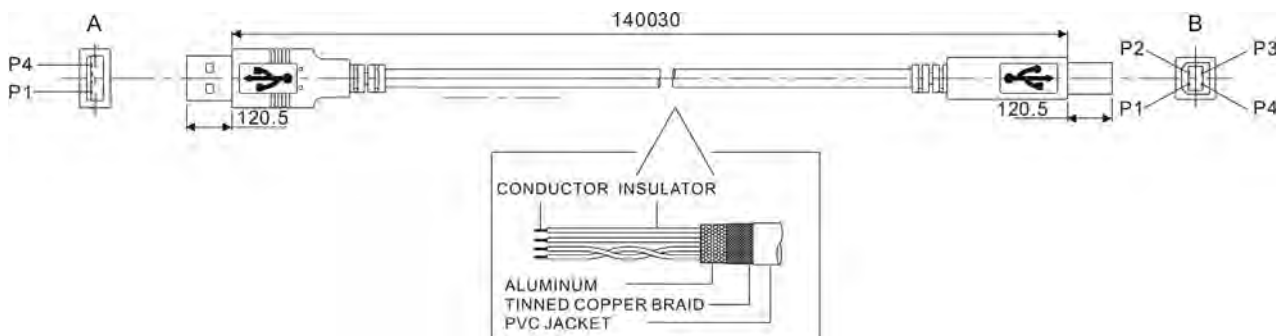
Delta Part Number: ASD-CARS0003



Title	Part No.	L	
		mm	inch
1	ASD-CARS0003	3000 ± 100	118 ± 4

■ **Communication Cable between Drive and Computer (for PC)**

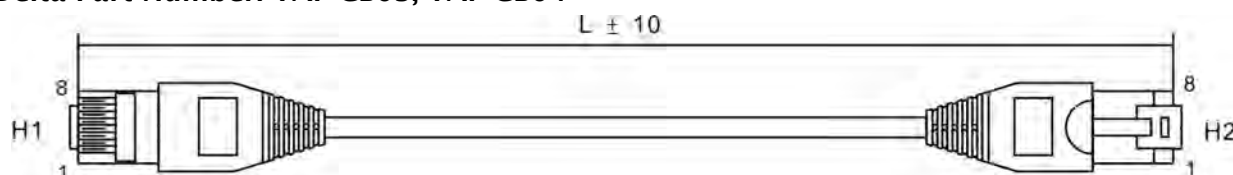
Delta Part Number: DOP-CAUSBAB



Title	Part No.	L	
		mm	inch
1	DOP-CAUSBAB	1400 ± 30	55 ± 1.2

■ **CANopen Communication Cable**

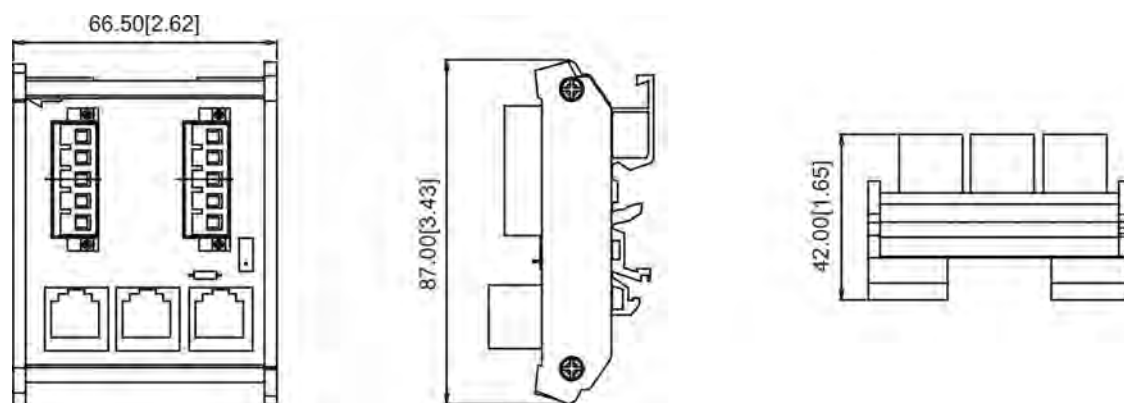
Delta Part Number: TAP-CB03, TAP-CB04



Title	Part No.	L	
		mm	inch
1	TAP-CB03	500 ± 10	19 ± 0.4
2	TAP-CB04	1000 ± 10	39 ± 0.4

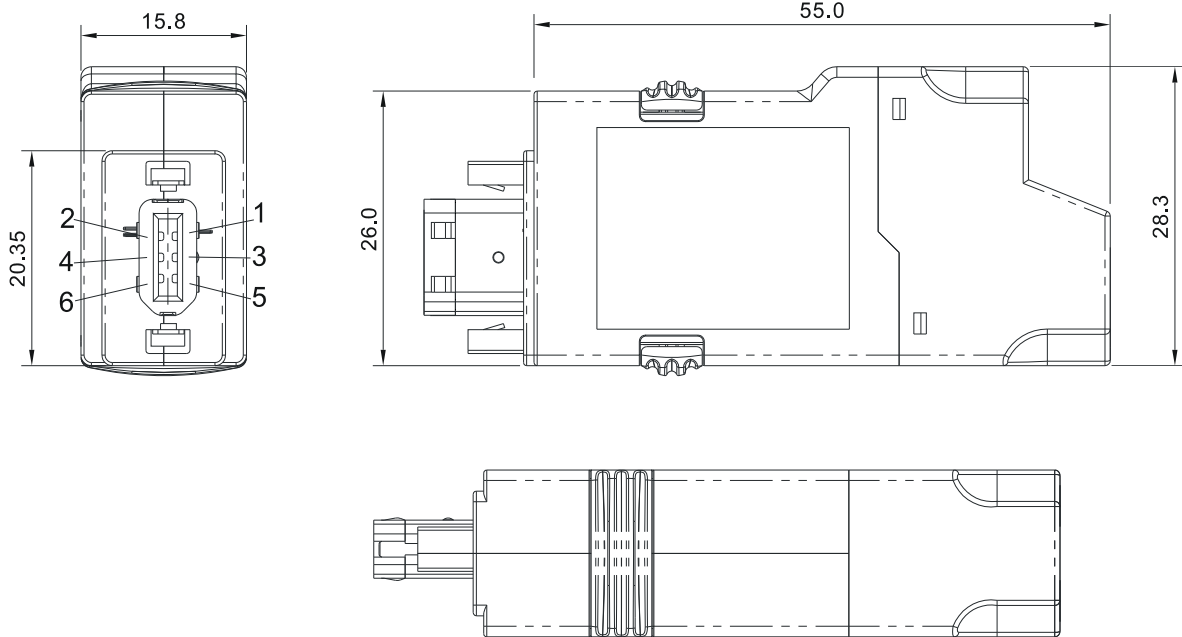
■ **CANopen Distribution Box**

Delta Part Number: TAP-CN03



■ RS-485 Connector

Delta Part Number: ASD-CNIE0B06



■ **Servo Drive, Servo Motor and Accessories Combinations - 220V Series**

100W Servo Drive and 100W Low Inertia Servo Motor

Servo Drive	ASD-A2-0121-□			
Servo Motor	ECMA-C10401□S			
Cable	Without Brake		With Brake	
	3M	5M	3M	5M
	Motor Power Cable ASD-ABPW0003	Power Cable ASD-ABPW0005	Power Cable ASD-ABPW0103	Power Cable ASD-ABPW0105
	Encoder Cable ASD-ABEN0003	Encoder Cable ASD-ABEN0005	Encoder Cable ASD-ABEN0003	Encoder Cable ASD-ABEN0005
Connector	Power Connector ASDBCAPW0000		Power Connector ASDBCAPW0100	
	Encoder Connector ASD-ABEN0000			

200W Servo Drive and 200W Low Inertia Servo Motor

Servo Drive	ASD-A2-0221-□			
Servo Motor	ECMA-C10602□S			
Cable	Without Brake		With Brake	
	3M	5M	3M	5M
	Motor Power Cable ASD-ABPW0003	Power Cable ASD-ABPW0005	Power Cable ASD-ABPW0103	Power Cable ASD-ABPW0105
	Encoder Cable ASD-ABEN0003	Encoder Cable ASD-ABEN0005	Encoder Cable ASD-ABEN0003	Encoder Cable ASD-ABEN0005
Connector	Power Connector ASDBCAPW0000		Power Connector ASDBCAPW0100	
	Encoder Connector ASD-ABEN0000			

400W Servo Drive and 400W Low Inertia Servo Motor

Servo Drive	ASD-A2-0421-□			
Servo Motor	ECMA-C10604□S ECMA-C10804□7			
Cable	Without Brake		With Brake	
	3M	5M	3M	5M
	Power Cable ASD-ABPW0003	Power Cable ASD-ABPW0005	Power Cable ASD-ABPW0103	Power Cable ASD-ABPW0105
	Encoder Cable ASD-ABEN0003	Encoder Cable ASD-ABEN0005	Encoder Cable ASD-ABEN0003	Encoder Cable ASD-ABEN0005
Connector	Power Connector ASDBCAPW0000		Power Connector ASDBCAPW0100	
	Encoder Connector ASD-ABEN0000			

Appendix A Accessories**ASDA-A2****400W Servo Drive and 500W Medium Inertia Servo Motor**

Servo Drive	ASD-A2-0421-□			
Servo Motor	ECMA-E11305□S			
Cable	Without Brake		With Brake	
	3M	5M	3M	5M
	Power Cable ASD-CAPW1003	Power Cable ASD-CAPW1005	Power Cable ASD-CAPW1103	Power Cable ASD-CAPW1105
	Encoder Cable ASD-CAEN1003	Encoder Cable ASD-CAEN1005	Encoder Cable ASD-CAEN1003	Encoder Cable ASD-CAEN1005
Connector	Power Connector ASD-CAPW1000			
	Encoder Connector ASD-CAEN1000			

400W Servo Drive and 300W High Inertia Servo Motor

Servo Drive	ASD-A2-0421-□			
Servo Motor	ECMA-G11303□S			
Cable	Without Brake		With Brake	
	3M	5M	3M	5M
	Power Cable ASD-CAPW1003	Power Cable ASD-CAPW1005	Power Cable ASD-CAPW1103	Power Cable ASD-CAPW1105
	Encoder Cable ASD-CAEN1003	Encoder Cable ASD-CAEN1005	Encoder Cable ASD-CAEN1003	Encoder Cable ASD-CAEN1005
Connector	Power Connector ASD-CAPW1000			
	Encoder Connector ASD-CAEN1000			

750W Servo Drive and 750W Low Inertia Servo Motor

Servo Drive	ASD-A2-0721-□			
Servo Motor	ECMA-C10807□S			
Cable	Without Brake		With Brake	
	3M	5M	3M	5M
	Power Cable ASD-ABPW0003	Power Cable ASD-ABPW0005	Power Cable ASD-ABPW0103	Power Cable ASD-ABPW0105
	Encoder Cable ASD-ABEN0003	Encoder Cable ASD-ABEN0005	Encoder Cable ASD-ABEN0003	Encoder Cable ASD-ABEN0005
Connector	Power Connector ASDBCAPW0000		Power Connector ASDBCAPW0100	
	Encoder Connector ASD-ABEN0000			

750W Servo Drive and 600W High Inertia Servo Motor

Servo Drive	ASD-A2-0721-□			
Servo Motor	ECMA-G11306□S			
Cable	Without Brake		With Brake	
	3M	5M	3M	5M
	Power Cable ASD-CAPW1003	Power Cable ASD-CAPW1005	Power Cable ASD-CAPW1103	Power Cable ASD-CAPW1105
	Encoder Cable ASD-CAEN1003	Encoder Cable ASD-CAEN1005	Encoder Cable ASD-CAEN1003	Encoder Cable ASD-CAEN1005
Connector	Power Connector ASD-CAPW1000			
	Encoder Connector ASD-CAEN1000			

1kW Servo Drive and 1kW Low Inertia Servo Motor

Servo Drive	ASD-A2-1021-□			
Servo Motor	ECMA-C11010□S			
Cable	Without Brake		With Brake	
	3M	5M	3M	5M
	Power Cable ASD-CAPW1003	Power Cable ASD-CAPW1005	Power Cable ASD-CAPW1103	Power Cable ASD-CAPW1105
	Encoder Cable ASD-CAEN1003	Encoder Cable ASD-CAEN1005	Encoder Cable ASD-CAEN1003	Encoder Cable ASD-CAEN1005
Connector	Power Connector ASD-CAPW1000			
	Encoder Connector ASD-CAEN1000			

1kW Servo Drive and 1kW Medium Inertia Servo Motor

Servo Drive	ASD-A2-1021-□			
Servo Motor	ECMA-E11310□S			
Cable	Without Brake		With Brake	
	3M	5M	3M	5M
	Power Cable ASD-CAPW1003	Power Cable ASD-CAPW1005	Power Cable ASD-CAPW1103	Power Cable ASD-CAPW1105
	Encoder Cable ASD-CAEN1003	Encoder Cable ASD-CAEN1005	Encoder Cable ASD-CAEN1003	Encoder Cable ASD-CAEN1005
Connector	Power Connector ASD-CAPW1000			
	Encoder Connector ASD-CAEN1000			

1kW Servo Drive and 900W High Inertia Servo Motor

Servo Drive	ASD-A2-1021-□			
Servo Motor	ECMA-G11309□S			
Cable	Without Brake		With Brake	
	3M	5M	3M	5M
	Power Cable ASD-CAPW1003	Power Cable ASD-CAPW1005	Power Cable ASD-CAPW1103	Power Cable ASD-CAPW1105
	Encoder Cable ASD-CAEN1003	Encoder Cable ASD-CAEN1005	Encoder Cable ASD-CAEN1003	Encoder Cable ASD-CAEN1005
Connector	Power Connector ASD-CAPW1000			
	Encoder Connector ASD-CAEN1000			

1.5kW Servo Drive and 1.5kW Medium Inertia Servo Motor

Servo Drive	ASD-A2-1521-□			
Servo Motor	ECMA-E11315□S			
Cable	Without Brake		With Brake	
	3M	5M	3M	5M
	Power Cable ASD-CAPW1003	Power Cable ASD-CAPW1005	Power Cable ASD-CAPW1103	Power Cable ASD-CAPW1105
	Encoder Cable ASD-CAEN1003	Encoder Cable ASD-CAEN1005	Encoder Cable ASD-CAEN1003	Encoder Cable ASD-CAEN1005
Connector	Power Connector ASD-CAPW1000			
	Encoder Connector ASD-CAEN1000			

2kW Servo Drive and 2kW Low Inertia Servo Motor

Servo Drive	ASD-A2-2023-□			
Servo Motor	ECMA-C11020□S			
Cable	Without Brake		With Brake	
	3M	5M	3M	5M
	Power Cable ASD-A2PW1003	Power Cable ASD-A2PW1005	Power Cable ASD-A2PW1103	Power Cable ASD-A2PW1105
	Encoder Cable ASD-CAEN1003	Encoder Cable ASD-CAEN1005	Encoder Cable ASD-CAEN1003	Encoder Cable ASD-CAEN1005
Connector	Power Connector ASD-CAPW1000			
	Encoder Connector ASD-CAEN1000			

2kW Servo Drive and 2kW Medium Inertia Servo Motor

Servo Drive	ASD-A2-2023-□			
Servo Motor	ECMA-E11320□S			
Cable	Without Brake		With Brake	
	3M	5M	3M	5M
	Power Cable ASD-A2PW1003	Power Cable ASD-A2PW1005	Power Cable ASD-A2PW1103	Power Cable ASD-A2PW1105
	Encoder Cable ASD-CAEN1003	Encoder Cable ASD-CAEN1005	Encoder Cable ASD-CAEN1003	Encoder Cable ASD-CAEN1005
Connector	Power Connector ASD-CAPW1000			
	Encoder Connector ASD-CAEN1000			

2kW Servo Drive and 2kW Medium Inertia Servo Motor

Servo Drive	ASD-A2-2023-□			
Servo Motor	ECMA-E11820□S			
Cable	Without Brake		With Brake	
	3M	5M	3M	5M
	Power Cable ASD-CAPW2003	Power Cable ASD-CAPW2005	Power Cable ASD-CAPW2103	Power Cable ASD-CAPW2105
	Encoder Cable ASD-CAEN1003	Encoder Cable ASD-CAEN1005	Encoder Cable ASD-CAEN1003	Encoder Cable ASD-CAEN1005
Connector	Power Connector ASD-CAPW2000			
	Encoder Connector ASD-CAEN1000			

3kW Servo Drive and 3kW Medium Inertia Servo Motor

Servo Drive	ASD-A2-3023-□			
Servo Motor	ECMA-E11830□S			
Cable	Without Brake		With Brake	
	3M	5M	3M	5M
	Power Cable ASD-CAPW2003	Power Cable ASD-CAPW2005	Power Cable ASD-CAPW2103	Power Cable ASD-CAPW2105
	Encoder Cable ASD-CAEN1003	Encoder Cable ASD-CAEN1005	Encoder Cable ASD-CAEN1003	Encoder Cable ASD-CAEN1005
Connector	Power Connector ASD-CAPW2000			
	Encoder Connector ASD-CAEN1000			

3kW Servo Drive and 3kW Medium-High Inertia Servo Motor

Servo Drive	ASD-A2-3023-□			
Servo Motor	ECMA-F11830□S			
Cable	Without Brake		With Brake	
	3M	5M	3M	5M
	Power Cable ASD-CAPW2003	Power Cable ASD-CAPW2005	Power Cable ASD-CAPW2103	Power Cable ASD-CAPW2105
	Encoder Cable ASD-CAEN1003	Encoder Cable ASD-CAEN1005	Encoder Cable ASD-CAEN1003	Encoder Cable ASD-CAEN1005
Connector	Power Connector ASD-CAPW2000			
	Encoder Connector ASD-CAEN1000			

4.5kW Servo Drive and 4.5kW Medium-High Inertia Servo Motor

Servo Drive	ASD-A2-4523-□			
Servo Motor	ECMA-F11845□S			
Cable	Without Brake		With Brake	
	3M	5M	3M	5M
	Power Cable ASD-CAPW3203	Power Cable ASD-CAPW3205	Power Cable ASD-CAPW3303	Power Cable ASD-CAPW3305
	Encoder Cable ASD-CAEN1003	Encoder Cable ASD-CAEN1005	Encoder Cable ASD-CAEN1003	Encoder Cable ASD-CAEN1005
Connector	Power Connector ASD-CAPW2000			
	Encoder Connector ASD-CAEN1000			

5.5kW Servo Drive and 5.5kW Medium-High Inertia Servo Motor

Servo Drive	ASD-A2-5523-□			
Servo Motor	ECMA-F11855□3			
Cable	Without Brake		With Brake	
	3M	5M	3M	5M
	-	-	-	-
	Encoder Cable ASD-CAEN1003	Encoder Cable ASD-CAEN1005	Encoder Cable ASD-CAEN1003	Encoder Cable ASD-CAEN1005
Connector	Power Connector ASD-CAPW4000			
	Encoder Connector ASD-CAEN1000			
	Brake Connector ASD-CNBR1000			

7.5kW Servo Drive and 7.5kW Medium-High Inertia Servo Motor

Servo Drive	ASD-A2-7523-□			
Servo Motor	ECMA-F11875□3			
Cable	Without Brake		With Brake	
	3M	5M	3M	5M
	-	-	-	-
	Encoder Cable ASD-CAEN1003	Encoder Cable ASD-CAEN1005	Encoder Cable ASD-CAEN1003	Encoder Cable ASD-CAEN1005
Connector	Power Connector ASD-CAPW4000			
	Encoder Connector ASD-CAEN1000			
	Brake Connector ASD-CNBR1000			

 **NOTE**

- 1) The boxes (□) at the ends of the servo drive model names are for optional configurations (Full-close control, CANopen, DMCNET and extension port for digital input). For the actual model name, please refer to the ordering information of the actual purchased product.
- 2) The boxes (□) in the servo motor model names are for optional configurations (keyway, brake and oil seal).

■ Servo Drive, Servo Motor and Accessories Combinations - **400V Series**

750W Servo Drive and 750W Low Inertia Servo Motor

Servo Drive	ASD-A2-0743-□			
Servo Motor	ECMA-J10807□S			
Cable	Without Brake		With Brake	
	3M	5M	3M	5M
	Power Cable ASD-ABPW0003	Power Cable ASD-ABPW0005	Power Cable ASD-ABPW0103	Power Cable ASD-ABPW0105
	Encoder Cable ASD-CAEN1003	Encoder Cable ASD-CAEN1005	Encoder Cable ASD-CAEN1003	Encoder Cable ASD-CAEN1005
Connector	Power Connector ASDBCAPW0000		Power Connector ASDBCAPW0100	
	Encoder Connector ASD-ABEN0000			

1kW Servo Drive and 1kW Medium Inertia Servo Motor

Servo Drive	ASD-A2-1043-□			
Servo Motor	ECMA-K11310□S			
Cable	Without Brake		With Brake	
	3M	5M	3M	5M
	Power Cable ASD-CAPW1003	Power Cable ASD-CAPW1005	Power Cable ASD-CAPW1103	Power Cable ASD-CAPW1105
	Encoder Cable ASD-CAEN1003	Encoder Cable ASD-CAEN1005	Encoder Cable ASD-CAEN1003	Encoder Cable ASD-CAEN1005
Connector	Power Connector ASD-CAPW1000			
	Encoder Connector ASD-CAEN1000			

1.5kW Servo Drive and 1.5kW Medium Inertia Servo Motor

Servo Drive	ASD-A2-1543-□			
Servo Motor	ECMA-K11315□S			
Cable	Without Brake		With Brake	
	3M	5M	3M	5M
	Power Cable ASD-CAPW1003	Power Cable ASD-CAPW1005	Power Cable ASD-CAPW1103	Power Cable ASD-CAPW1105
	Encoder Cable ASD-CAEN1003	Encoder Cable ASD-CAEN1005	Encoder Cable ASD-CAEN1003	Encoder Cable ASD-CAEN1005
Connector	Power Connector ASD-CAPW1000			
	Encoder Connector ASD-CAEN1000			

ASDA-A2**Appendix A Accessories****2kW Servo Drive and 2kW Medium Inertia Servo Motor**

Servo Drive	ASD-A2-2043-□			
Servo Motor	ECMA-K11320□S			
Cable	Without Brake		With Brake	
	3M	5M	3M	5M
	Power Cable ASD-CAPW1203	Power Cable ASD-CAPW1205	Power Cable ASD-CAPW1303	Power Cable ASD-CAPW1305
	Encoder Cable ASD-CAEN1003	Encoder Cable ASD-CAEN1005	Encoder Cable ASD-CAEN1003	Encoder Cable ASD-CAEN1005
Connector	Power Connector ASD-CAPW1000			
	Encoder Connector ASD-CAEN1000			

3kW Servo Drive and 3kW Medium-High Inertia Servo Motor

Servo Drive	ASD-A2-3043-□			
Servo Motor	ECMA-K11830□S			
Cable	Without Brake		With Brake	
	3M	5M	3M	5M
	Power Cable ASD-CAPW2203	Power Cable ASD-CAPW2205	Power Cable ASD-CAPW2303	Power Cable ASD-CAPW2305
	Encoder Cable ASD-CAEN1003	Encoder Cable ASD-CAEN1005	Encoder Cable ASD-CAEN1003	Encoder Cable ASD-CAEN1005
Connector	Power Connector ASD-CAPW2000			
	Encoder Connector ASD-CAEN1000			

4.5kW Servo Drive and 4.5kW Medium-High Inertia Servo Motor

Servo Drive	ASD-A2-4543-□			
Servo Motor	ECMA-L11845□S			
Cable	Without Brake		With Brake	
	3M	5M	3M	5M
	Power Cable ASD-CAPW2203	Power Cable ASD-CAPW2205	Power Cable ASD-CAPW2303	Power Cable ASD-CAPW2305
	Encoder Cable ASD-CAEN1003	Encoder Cable ASD-CAEN1005	Encoder Cable ASD-CAEN1003	Encoder Cable ASD-CAEN1005
Connector	Power Connector ASD-CAPW2000			
	Encoder Connector ASD-CAEN1000			

5.5kW Servo Drive and 5.5kW Medium-High Inertia Servo Motor

Servo Drive	ASD-A2-5543-□			
Servo Motor	ECMA-L11855□3			
Cable	Without Brake		With Brake	
	3M	5M	3M	5M
	Power Cable ASD-CAPW2203	Power Cable ASD-CAPW2205	Power Cable ASD-CAPW2303	Power Cable ASD-CAPW2305
	Encoder Cable ASD-CAEN1003	Encoder Cable ASD-CAEN1005	Encoder Cable ASD-CAEN1003	Encoder Cable ASD-CAEN1005
Connector	Power Connector ASD-CAPW2000			
	Encoder Connector ASD-CAEN1000			

7.5kW Servo Drive and 7.5kW Medium-High Inertia Servo Motor

Servo Drive	ASD-A2-7543-□			
Servo Motor	ECMA-L11875□3			
Cable	Without Brake		With Brake	
	3M	5M	3M	5M
	Power Cable ASD-CAPW3203	Power Cable ASD-CAPW3205	Power Cable ASD-CAPW3303	Power Cable ASD-CAPW3305
	Encoder Cable ASD-CAEN1003	Encoder Cable ASD-CAEN1005	Encoder Cable ASD-CAEN1003	Encoder Cable ASD-CAEN1005
Connector	Power Connector ASD-CAPW2000			
	Encoder Connector ASD-CAEN1000			

 **NOTE**

- 1) The boxes (□) at the ends of the servo drive model names are for optional configurations (Full-close control, CANopen, DMCNET and extension port for digital input). For the actual model name, please refer to the ordering information of the actual purchased product.
- 2) The boxes (□) in the servo motor model names are for optional configurations (keyway, brake and oil seal).

Other Accessories

Other Accessories (for ASDA-A2 series all models)	
Description	Delta Part Number
50Pin I/O signal connector (CN1)	ASD-CN5C0050
Terminal Block Module	ASD-BM-50A
RS-232 Communication Cable	ASD-CARS0003
Communication Cable between Drive and Computer (for PC)	DOP-CAUSBAB
CANopen Communication Cable	TAP-CB03/TAP-CB04
CANopen Distribution Box	TAP-CN03
RS-485 Connector	ASD-CNIE0B06
Regenerative Resistor 400W 40Ω	BR400W040
Regenerative Resistor 1kW 20Ω	BR1K0W020
Regenerative Resistor 3kW 10Ω	BR1K5W005

This page intentionally left blank

Appendix B Maintenance and Inspection

Delta AC servo drives are based on solid state electronics technology. Preventive maintenance is required to operate this AC servo drives in its optimal condition, and to ensure a long life. It is recommended to perform a periodic maintenance and inspection of the AC servo drive by a qualified technician. Before any maintenance and inspection, always turn off the AC input power to the unit.



➤ ***Be sure to disconnect AC power and ensure that the internal capacitors have fully discharged before performing the maintenance and inspection!***

Basic Inspection

After power is in connected to the AC servo drive, the charge LED will be lit which indicates that the AC servo drive is ready.

Item	Content
General Inspection	<ul style="list-style-type: none"> ● Periodically inspect the screws of the servo drive, motor shaft, terminal block and the connection to mechanical system. Tighten screws as necessary as they may loosen due to vibration and varying temperatures. ● Ensure that oil, water, metallic particles or any foreign objects do not fall inside the servo drive, motor, control panel or ventilation slots and holes. As these will cause damage. ● Ensure the correct installation and the control panel. It should be free from airborne dust, harmful gases or liquids. ● Ensure that all wiring instructions and recommendations are followed; otherwise damage to the drive and or motor may result.
Inspection before operation (Control power is not applied)	<ul style="list-style-type: none"> ● Inspect the servo drive and servo motor to insure they were not damaged. ● To avoid an electric shock, be sure to connect the ground terminal of servo drive to the ground terminal of control panel. ● Before making any connection, wait 10 minutes for capacitors to discharge after the power is disconnected, alternatively, use an appropriate discharge device to discharge. ● Ensure that all wiring terminals are correctly insulated. ● Ensure that all wiring is correct or damage and or malfunction may result. ● Visually check to ensure that there are not any unused screws, metal strips, or any conductive or inflammable materials inside the drive. ● Never put inflammable objects on servo drive or close to the external regenerative resistor. ● Make sure control switch is OFF. ● If the electromagnetic brake is being used, ensure that it is correctly wired.

Item	Content
Inspection before operation (Control power is not applied)	<ul style="list-style-type: none"> ● If required, use an appropriate electrical filter to eliminate noise to the servo drive. ● Ensure that the external applied voltage to the drive is correct and matched to the controller.
Inspection during operation (Control power is applied)	<ul style="list-style-type: none"> ● Ensure that the cables are not damaged, stressed excessively or loaded heavily. When the motor is running, pay close attention on the connection of the cables and notice that if they are damaged, frayed or over extended. ● Check for abnormal vibrations and sounds during operation. If the servo motor is vibrating or there are unusual noises while the motor is running, please contact the dealer or manufacturer for assistance. ● Ensure that all user-defined parameters are set correctly. Since the characteristics of various machinery are different, in order to avoid accident or cause damage, do not adjust the parameter abnormally and ensure the parameter setting is not an excessive value. ● Ensure to reset some parameters when the servo drive is off (Please refer to Chapter 7). Otherwise, it may result in malfunction. ● If there is no contact sound or there be any unusual noises when the relay of the servo drive is operating, please contact your distributor for assistance or contact with Delta. ● Check for abnormal conditions of the power indicators and LED display. If there is any abnormal condition of the power indicators and LED display, please contact your distributor for assistance or contact with Delta.

Maintenance

- Use and store the product in a proper and normal environment.
- Periodically clean the surface and panel of servo drive and motor.
- Make sure the conductors or insulators are corroded and/or damaged.
- Do not disassemble or damage any mechanical part when performing maintenance.
- Clean off any dust and dirt with a vacuum cleaner. Place special emphasis on cleaning the ventilation ports and PCBs. Always keep these areas clean, as accumulation of dust and dirt can cause unforeseen failures.

Life of Replacement Components

■ Smooth capacitor

The characteristics of smooth capacitor would be deteriorated by ripple current affection. The life of smooth capacitor varies according to ambient temperature and operating conditions. The common guaranteed life of smooth capacitor is ten years when it is properly used in normal air-conditioned environment.

■ Relay

The contacts will wear and result in malfunction due to switching current. The life of relay varies according to power supply capacity. Therefore, the common guaranteed life of relay is cumulative 100,000 times of power on and power off.

■ Cooling fan

The cooling fan life is limited and should be changed periodically. The cooling fan will reach the end of its life in 2~3 years when it is in continuous operation. However, it also must be replaced if the cooling fan is vibrating or there are unusual noises.

This page intentionally left blank.